

2024

Computer Fundamentals

Dr. Babasaheb Ambedkar Open University



Computer Fundamentals

Course Writer

Ashenafi Kassahun

Content Editor

Mr. Nilesh N. Bokhani

Assistant Professor,
School of Computer Science,
Dr. Babasaheb Ambedkar Open University

Acknowledgement: The content in this book is modifications based on the work created and shared by the African Virtual University (AVU) for the subject Fundamentals of Computer Organization and Architecture used according to terms described in Creative Commons Attribution-ShareAlike 4.0 International (CC BY-SA 4.0)

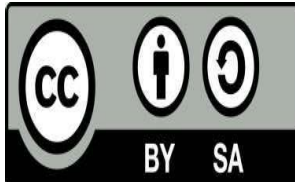

This publication is made available under a Creative Commons Attribution-ShareAlike 4.0 International (CC BY-SA 4.0)
<https://creativecommons.org/licenses/by-sa/4.0/>

ISBN -

Printed and published by: Dr. Babasaheb Ambedkar Open University, Ahmedabad

While all efforts have been made by editors to check accuracy of the content, the representation of facts, principles, descriptions and methods are that of the respective module writers. Views expressed in the publication are that of the authors, and do not necessarily reflect the views of Dr. Babasaheb Ambedkar Open University. All products and services mentioned are owned by their respective copyrights holders, and mere presentation in the publication does not mean endorsement by Dr. Babasaheb Ambedkar Open University. Every effort has been made to acknowledge and attribute all sources of information used in preparation of this learning material. Readers are requested to kindly notify missing attribution, if any.

Computer Fundamentals

Block-1 Introduction to Computer

UNIT-1 Introduction of Computer Parts	05
UNIT-2 System Architecture and Design	09
UNIT- 3 Micro Architecture	27

Block-2 Computer Architecture

UNIT-4 Instruction set Architecture (ISA)	37
UNIT-5 Impact and History of Computers	60
UNIT-6 Computer Hardware	79
UNIT-7 Computing and Data Processing	96
UNIT-8 Software	110

Block-3 Input, Output and Storage Devices

UNIT-9 File and Data Management	127
UNIT-10 Input Device	136
UNIT-11 Output Device and Storage Device	148
UNIT-12 Communications and Connectivity	162

Block-4 Data Representation and Logic

UNIT-13 Number System	177
UNIT-14 Logic Gates	186

Unit 1: Introduction of Computer Parts

1

Unit Introduction

The purpose of this unit is to determine your understanding of previous knowledge related to this course. In this unit, you will be given assessment that is geared towards reminding you of self the common usage of the computer functions and capabilities which you have encountered before. You will explore the common parts of the computer and what they are used for. This is to prepare you for more detailed discussion which you will learn about these parts and their functions in the other units.

Unit Objectives

Upon completion of this unit you should be able to:

1. Identify the main components of a computer.
2. Describe the functions main components of computer identified above...

Key Terms

Hardware :The physical components of the computer system.

Software: The programs or instructions that tell the computer what to do.

CPU: The brain of the computer or central processing unit.

ROM: The permanent memory that is built in your computer. This is read only.

RAM: The computer's working memory, sometimes called random-accessed memory.

Megabyte: Approximately a million bytes.

Gigabyte: Approximately a billion bytes (or 1,000 megabytes).

Input Device: The hardware that is used to pass information into the computer.

Output Device: The hardware that receives and displays information coming from the computer.

Modem; The device that allows your computer to talk to other computers over a telephone line.

Monitor; A video or computer display device.

Laser Printer; A printer that uses both laser and photographic technology to produce high quality output.

Printer; The hardware that provides printed output from the computer.

Hard Copy; A printed copy of computer output.

Compact Disc; A disc on which a laser has digitally recorded information such as audio, video, or computer data.

Hard Disk; A fixed, large-capacity magnetic storage medium for computer data.

Floppy Disk; A portable magnetic storage medium for computer data that allows users to randomly access information.

Graphical User Interface; The use of graphical symbols instead of text commands to control common computer functions such as copying programs and disks.

Icon; A small picture or symbol representing a computer hardware function or component.

Ink-jet Printer; A type of printer that forms letters on the page by shooting tiny electrically charged droplets of ink.

Unit Assessment

Check your understanding

Identify the parts of the computer system as shown in figure 1



Figure 1.0 : Parts of Computer System

(Retrieved from <http://www.proprofs.com/quiz-school/story.php?title=label-computer-input-output-parts>- Label The Computer, Input, Output, Parts)

1. Which component or the hardware part is responsible for arithmetic/logic operations?
 - a: CPU
 - b: RAM
 - c: OS
2. Apart from the computer screen, name two other devices that are used to display the output from a computer
3. What is a computer system unit?
4. What is the name of the internal component that all other components tie into?
5. Which one is an INPUT device?
 - a. Floppy Disk
 - b. Keyboard
 - c. Monitor
 - d. Speakers

6. Which one is a STORAGE device?

- a. CPU
- b. Headphones
- c. Floppy Disk
- d. Modem

Feedback

Follow the link and see if you have answered correctly.

1. <http://www.proprofs.com/quiz-school/story.php?title=label-computer-input-output-parts>

Unit Readings and Other Resources

The readings in this unit are to be found at the course-level section “Readings and Other Resources”.

1. <https://drive.google.com/viewerng/=ZGVmYXVsdGRvbWFpbXjYXNpdGVmb3JzdHVkZW50c3xneDoxOWY2NTE2NWE4MTk4MDcx-> Course Objectives - Computer Organization and Architecture
2. http://en.wikibooks.org/wiki/Introduction_to_Computer_Information_Systems/Application_Software- Introduction to Computer Information Systems/Application Software

Unit 2: System Architecture and Design

2

Introduction

This unit will include the components of a computer including input, central processing unit (CPU), the memory, storage and output. The functions of these components will also be covered including where they are found in a computer. The unit will introduce you to the basic principles of computer architecture. These principles will include how the computer motherboard is able to provide connections to all other components to form a computer system.

Unit Objectives

At the end of this unit, you should be able to:-

1. Identify the functional components of a computer.
2. Describe the functions of the identified computer components, and
3. List the main principles of computer architecture.

Key Terms

A system architecture or systems architecture is the conceptual model that defines the structure, behavior, and more views of a system, (Systems architecture, Retrieved April 27, 2016, from https://en.wikipedia.org/wiki/Systems_architecture)

Computer architecture is a specification detailing how a set of software and hardware technology standards interact to form a computer system or platform. In short, computer architecture refers to how a computer system is designed and what technologies it is compatible with (Computer_ architecture , Retrieved April 27, 2016, from https://en.wikipedia.org/wiki/Computer_architecture)

Introduction

Functional Components of Computer System

Computers have input devices such as keyboard, mouse, joystick, light pen, trackball, scanner, graphic tablet, microphone, magnetic ink card reader (MICR), optical character reader (OCR), bar code reader, optical mark reader (OMR). Computers also have output devices that are used to bring to the computer what the computer stores. These output devices include monitors, graphic plotters and printers (Computer fundamentals Tutorials, Retrieved from http://www.tutorialspoint.com/computer_fundamentals/index.htm)

The diagram showing the relationships between the input units, processing units and the output as is shown in the diagram below.

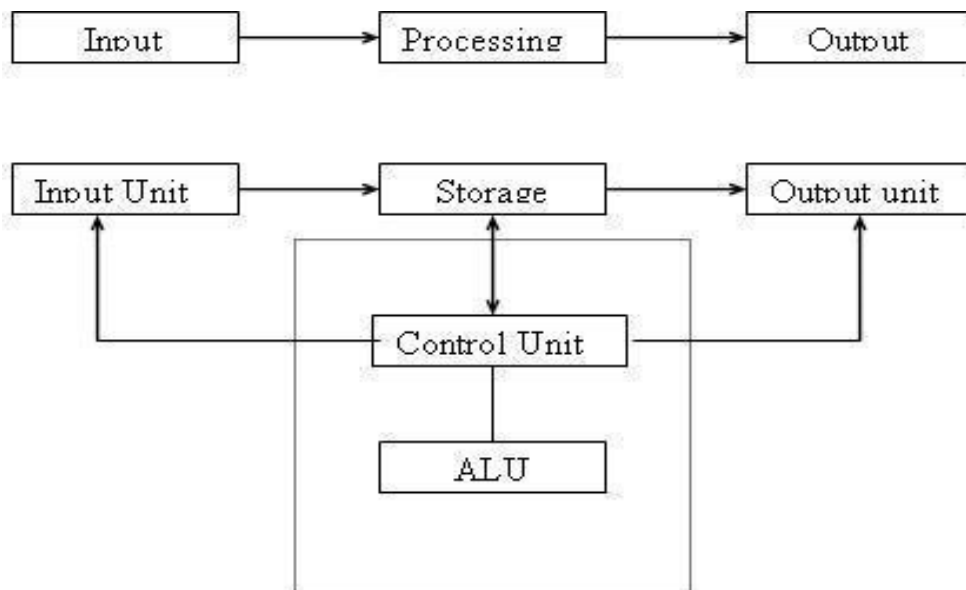

Figure 1.2: Functional Components of Computer System (Von Neumann Architecture)

Retrieved on 7th March, (2016) Available from wiki educator free learning content at: <http://wikieducator.org/File:CR-rie.jpg>

Input Unit

An input unit is made up of those devices that translate data into a form the computer can understand. They are divided into three types which are Keyboard hardware, the Pointing device and the Source data-entry.

Keyboard hardware: This is the part of the input unit that converts letters, numbers, and other characters into electrical signals that are machine-readable by the computer's processors (retrieved from <https://www.koofers.com/flashcards/is-chapter-5/review>).It looks like typewriter keyboard and contains alphabetical & alphanumeric characters, numbers and other function keys.

Pointing devices: This part controls the position of the cursor or pointer on the screen. Example are; mice, light-pens, touchpad's ,joysticks (adapted from <http://www.knowsh.com/NotesSearch/NotesDetail/80105/Input-Devices,-Keyboard,-Mouse,-Joy-Stick,-Light-pen,-Track-Ball,-Scanner,-Graphic-Tablet,-Microphone,-Magnetic-Ink-Card-Reader,-Optical-Character-Reader,-Bar-Code-Reader,-Optical-Mark-Reader>)

Source data-entry devices: these are devices that are not keyboards or pointing devices. Data-entry devices that create machine-readable data on magnetic media or paper or feed it directly into the computer's processor, without the use of a keyboard. Categories include scanning devices (imaging systems, bar-code readers, mark and character – recognition devices, and fax machines), audio-input devices, video input, photographic input (digital cameras), voice-recognition systems, sensors, radio-frequency identification devices, and human-biology-input devices (<https://www.koofers.com/flashcards/is-chapter-5/review>)

Storage Unit

This unit is made up of those devices that are to store data or instructions in the computer

system. They divided into three types (a) main memory (b) secondary memory and (c) the registers (Computer fundamentals Tutorials, Retrieved from http://www.tutorialspoint.com/computer_fundamentals/index.htm)

Main memory: The main memory is used for holding data and instructions which will be needed for use by the central processing unit. It's characterized by fast accessing information, low capacity and high costs. They are two main types

1. RAM – Random Access Memory

They can both be read, to retrieve information or written into, to store information. The contents of RAM remain stable as long as power is available i.e. volatile and has a short time response.



Figure 1. 3: Computer memory

(Computer fundamentals Tutorials, Retrieved from http://www.tutorialspoint.com/computer_fundamentals/index.htm)

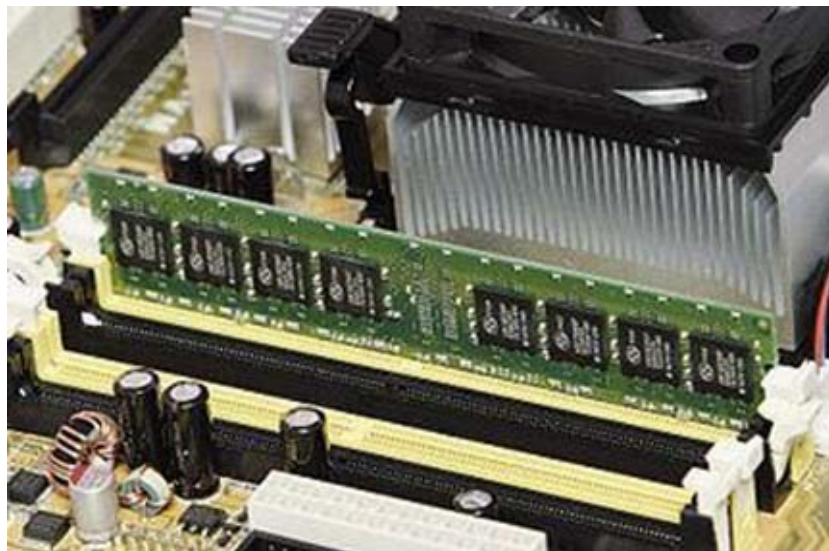

Figure 1.4: Computer System Memory Slot

Source: https://en.wikibooks.org/wiki/How_To_Assemble_A_Desktop_PC/Assembly

- a. Static RAM (SRAM)
- b. Dynamic RAM (DRAM)

Static RAM (SRAM) retain its contents even as long as the power is available. Used by manufactures to programme computer system programs. For example programming basic input output systems (BIOS) programs. Once the SRAM is written into the contents cannot be

erased. It changes to ROM

(Computer fundamentals Tutorials, Retrieved from http://www.tutorialspoint.com/computer_fundamentals/computer_ram.htm and Computer organization Tutorial, Retrieved April 27, 2016, from http://www.tutorialspoint.com/computer_logical_organization/memory_devices.htm



Figure 1. 5 : RAM Module

Available and Retrieved on 12th March, (2016) at

http://www.tutorialspoint.com/computer_fundamentals/computer_ram.htm



Figure 1.6: A 32 x 32 core memory plane storing 1024 bits of data.

Available and Retrieved on 12th March, (2016) at : http://en.wikipedia.org/wiki/Magnetic-core_memory

Characteristic of the SRAM (Learn computer fundamentals. (2016). Retrieved March 14, 2016, from http://www.tutorialspoint.com/computer_fundamentals/computer_ram.htm-)

Dynamic RAM (DRAM)

DRAM, must be continually refreshed (connected to power) in order to maintain the data. This is done connecting the memory on a refresh circuit that rewrites the data several hundred times per second. DRAM is commonly used by most system memory because it is small and cheap. All DRAMs are made of memory cells which are composed of one transistor and one capacitor..

Characteristics of the Dynamic RAM (Learn computer fundamentals. (2016). Retrieved March

14, 2016, from http://www.tutorialspoint.com/computer_fundamentals/computer_ram.htm)

The Dynamic RAM has a short data lifetime, it has to be refreshed often, is known to be slower than SRAM. It is smaller in size and can be used as RAM. DRAM is expensive and consumes less power.

Read Only Memory (ROM)

This memory provides a permanent or a semi permanent storage. Its contents can be read but it cannot be rewritten within the normal computer operations. The memory is non volatile and is not affected by power outages. The memory stores instructions that are used to start a computer in what is known as a bootstrap operation.

There are various types of ROM (available at Learn computer fundamentals. (2016) , Retrieved March 14, 2016, from http://www.tutorialspoint.com/computer_fundamentals/computer_ram.htm). They include

1. Masked ROM (MROM) considered to be the first ROMs that were hard-wired and contained preprogrammed set of data or instructions. They are not very expensive.
2. Programmable Read only Memory (PROM)

This a read only memory that can be modified by a user only once by entering desired contents using PROM program.It can be programmed once and is not erasable.

(available at Learn computer fundamentals. (2016). Retrieved March 14, 2016, from http://www.tutorialspoint.com/computer_fundamentals/computer_ram.htm) -

Advantages of ROM

1. Non-volatile in nature
2. These cannot be accidentally changed
3. Cheaper than RAMs
4. Easy to test
5. More reliable than RAMs
6. These are static and do not require refreshing
7. Its contents are always known and can be verified

(Computer organization Tutorial, Retrieved April 27, 2016, from http://www.tutorialspoint.com/computer_logical_organization/memory_devices.htm and in [Computer fundamentals Tutorials, Retrieved from http://www.tutorialspoint.com/computer_fundamentals/computer_ram.htm](http://www.tutorialspoint.com/computer_fundamentals/computer_ram.htm))

Storage standards

Storage standards are used for storing backup information that is not needed immediately by the CPU. They are characterized by slow access of information, higher capacity and lower cost. Examples: hard disk, floppy, CD, DVD.

Sector and track in hard disk

A Sector in the context of computing refers to a small area of a storage device, for example a

hard disk drive. A typical hard disk drive when low-level formatted is split into tracks, sectors and clusters:

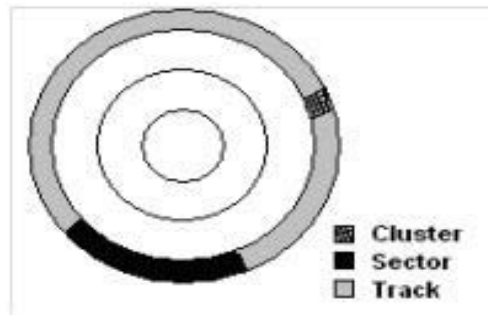

Figure 1.7: Cluster, sector and track

Retrieved March 14, 2016, Available at : <http://www.helpwithpcs.com/jargon/sector-track-cluster.htm>

CD-ROM and DVD-ROM

DVD is optical disc storage media format used for data storage. DVDs are of the same form factor as compact discs (CDs), but can store more data than CDs

Advantages of Storage standards

1. Storage capacity: Going by the storage capacity, the DVD specifications have four disk configurations, ranging from 4.7 GB to 17 GB. It ranges from single-sided and single-layer disks.
2. Speed of data transfer: The data transfer rate of DVD ROM is approximately equivalent to a 92X CD ROM.
3. Reliability: CD ROMs are very reliable and have a long shelf life yet if compared to the DVD, the DVD scores over the CDs in terms of reliability. Since DVD ROM discs are made of plastics bonded together, the discs are more rigid than CD ROM discs.

(Computer fundamentals Tutorials, Retrieved from http://www.tutorialspoint.com/computer_fundamentals/index.htm)

There are two types of access storage devices methods

1. Sequential Access Storage Devices (SASD): Data is stored in sequential order. Retrieval is also sequential.

Characteristics of SASD

- a. Storage media is magnetic tape.
 - b. Supports batch processing environment
 - c. Excellent form of backup Computer organization Tutorial, Retrieved April 27, 2016, from http://www.tutorialspoint.com/computer_logical_organization/memory_devices.htm)
2. Direct Access Storage Devices (DASD): Data can be stored and retrieved randomly.

Characteristics of DASD

- a. Storage capacity has high density. How tightly packed data is on the disk.

b.DASD is required for transaction processing.(Computer organization Tutorial, Retrieved April 27, 2016, from http://www.tutorialspoint.com/computer_logical_organization/memory_devices.htm)

Registers

Registers are high speed circuits that are a staging area for temporarily storing data during processing. This is a part of Central Processor Unit, so they reside inside the CPU. The information from main memory is brought to CPU and keep the information in register. Due to space and cost constraints, we have got a limited number of registers in a CPU. These are basically faster devices.

Cache Memory

This is a high speed memory which is used to speed up the CPU. It is found in between the CPU and the main memory. Its main purpose is to hold the data and programs which are frequently used by the CPU. These data and programs are transferred from the disk to this memory by the operating system and the CPU can then access them. This memory also stores data that may service future requests for the same data and makes the access faster. What is stored may be results of an earlier computation and/or the duplicates of data that is stored elsewhere. The use of this memory has certain advantages that include the following.

1. It is faster than main memory.
2. It consumes less access time as compared to main memory.
3. It stores the program that can be executed within a short period of time.
4. It stores data for temporary use. There are also a list of its disadvantages that include:-

The disadvantages of cache memory are as follows:

1. It has limited capacity.
2. It is volatile and is very expensive.

ComputerfundamentalsTutorials, Retrieved from http://www.tutorialspoint.com/computer_fundamentals/index.htm)

Virtual Memory

Virtual memory is an addressing scheme implemented in hardware and software that allows non-contiguous memory to be addressed as if it were contiguous. It maps memory addresses used by a program, called virtual addresses, into physical addresses in computer memory.

Main storage as seen by a process or task appears as a contiguous address space or collection of contiguous segments.

Programs can address data that does not currently reside in main memory. When this occurs, the hardware and operating system automatically load the data at the requested address from auxiliary storage into main memory. This occurs transparently to the user program. As a result, programs can reference a larger amount of (RAM) memory than actually exists in the computer using the stored concept facilitate by system software in managing main memory and secondary memory to swap contents between the two storage systems location.

System Board [Motherboard]

The motherboard contains the CPU, the memory and all the connectors to the other parts of the computer system. It provides connection for all the other components (adapted from Parts of a motherboard. Retrieved May 3, 2016, from <http://study.com/academy/lesson/what-is-a-motherboard-definition-function-diagram.html>)

A typical motherboard has:-

1. A CPU socket- this is where the CPU is directly connected. The power socket has a number of heat sinks and there are also mounting points where fans that ensure that the CPU does not overheat. When in use, the CPU generates a lot of heat. Heat.
2. There is a power connector which distributes power to the central processing unit and the other components of the motherboard.
3. The motherboard has a chip that acts as an interface between the central processing unit, the memory and the other components of the motherboard. This chip is known as the Northbridge. This generates lots of heat and has a large heat sink. There is also another chip that is used to control the input/output functions (I/O). It is known as the southbridge. Unlike the northbridge, this chip is not connected to the CPU. The two chips are combined to form a single chipset as shown in figure 1.11.
4. There are several connectors that provide physical interfaces between the I/O devices and the motherboard. The Southbridge is the one that handles these connections.
5. There are integrated Drive Electronics (IDE) and the Serial Advance Technology Advancement (SATA) which are slots for hard drives used to store files.
6. There is also a ROM chip that contains the startup instructions for the system. This chip is also known as the BIOS.
7. There are slots for videos and graphics cards like the Accelerated Graphics Port (AGP) and the Peripheral Component Interconnect Express (PCIe)

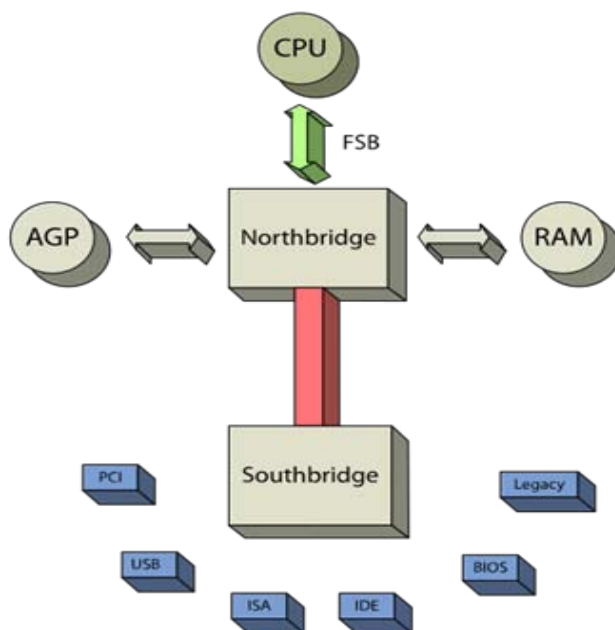

Figure: 1.11 "Chipset schematic" by Fred the Oyster.

Available and retrieved on 12th March, (2016) at: http://commons.wikimedia.org/wiki/File:Chipset_schematic.svg#/media/File:Chipset_schematic.svg

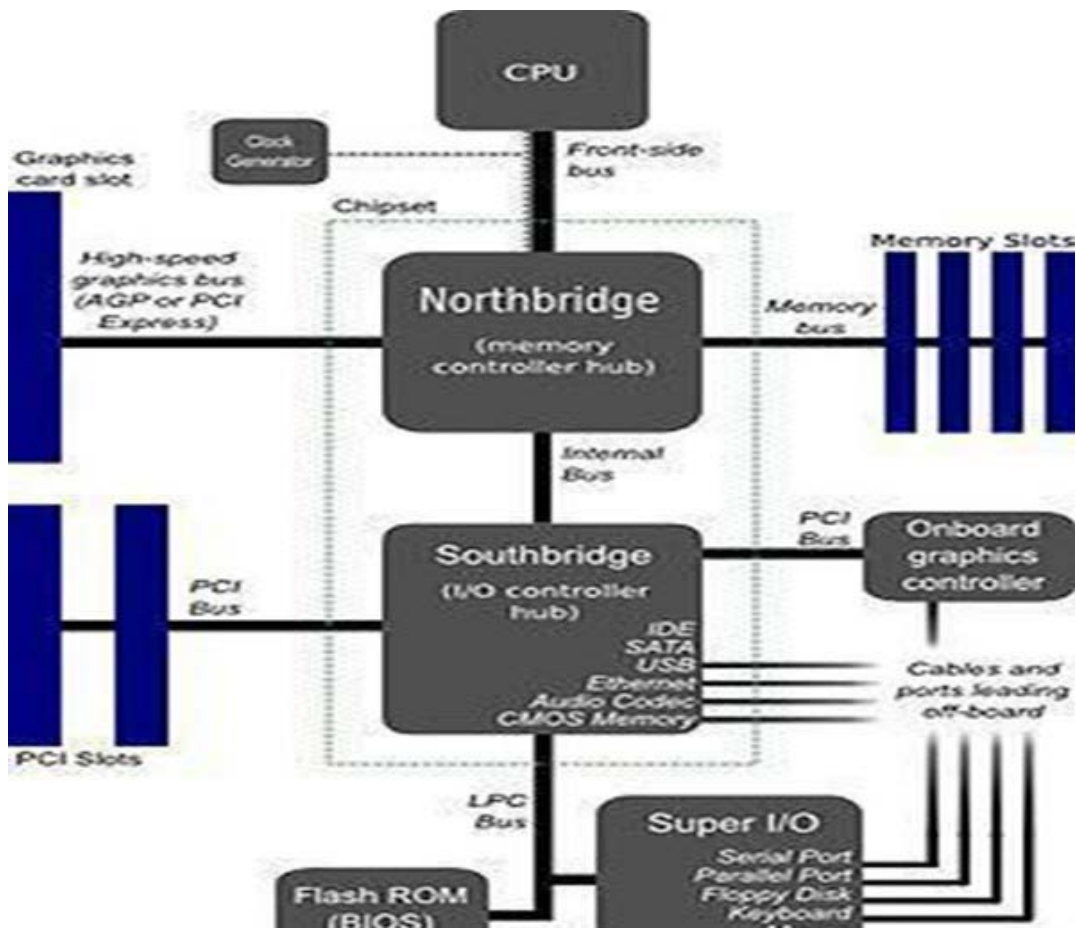

Figure: 1.12: Moxfyre (Image:Motherboard_diagram.svg)

Available & retrieved on 12th March, (2016) at: P. M. (n.d.). Introduction to computers. Retrieved May 3, 2016, from http://cs.sru.edu/~mullins/cpsc100book/module03_internalHardware/module03-01_internalHardware.html

Creative Commons Attribution-ShareAlike 3.0 Unported License.

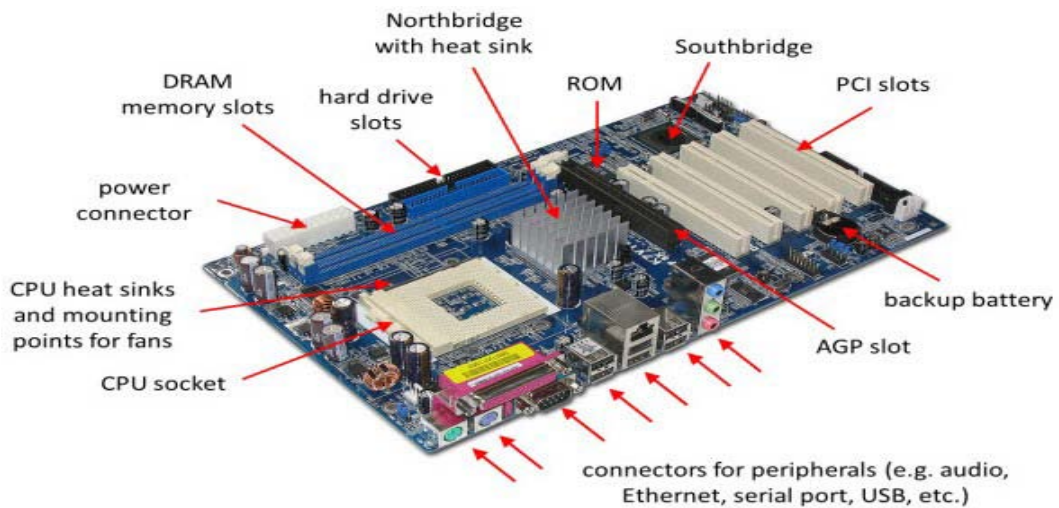

Figure 1.13: System board main components and parts.

(adapted from Parts of a motherboard. Retrieved May 3, 2016, from <http://study.com/academy/lesson/what-is-a-motherboard-definition-function-diagram.html>)

An example of PCI devices is shown in the diagrams that follows:



Figure 1.14a: A typical 32-bit, 5 V-only PCI card, in this case, a SCSI adapter from Adaptec.

(adopted from PCI card adapter. (n.d.). Retrieved May 3, 2016, from https://commons.wikimedia.org/wiki/File:32-bit_PCI_card.JPG

Creative Commons Attribution-Share Alike 3.0 Unported)

Motherboards for different models are of various designs as shown in the diagrams that follow.

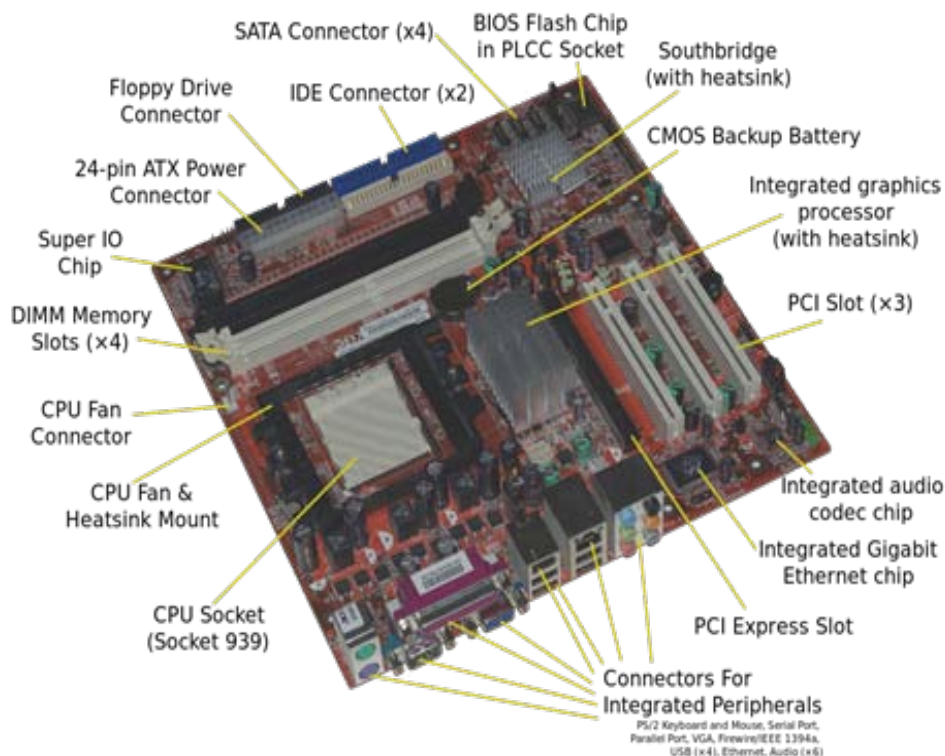

Figure 1.14c :Acer E360 Socket 939 motherboard by Foxconn.

Acer Socket Motherboard. (Retrieved May 3, 2016, from https://commons.wikimedia.org/wiki/File:Acer_E360_Socket_939_motherboard_by_Foxconn.svg

Creative Commons Attribution-Share Alike 3.0 Unported)

Motherboard for an Acer desktop personal computer, showing the typical components and interfaces that are found on a motherboard. This model was made by Foxconn in 2007, and follows the ATX layout (known as the “form factor”) usually employed for desktop computers. It is designed to work with AMD’s Athlon 64 processor



Figure:1.14d: Intel D945GCPE A microATX Motherboard LGA775 for Intel Pentium 4, D, XE, Dual-Core, Core 2 (circa 2007)

(Adopted from J. P. (n.d.). Intel Motherboard. Retrieved May 3, 2016, from https://commons.wikimedia.org/wiki/File:Intel_D945GCPE_Board.JPG

Creative Commons Attribution-Share Alike 4.0 International)



Figure 1.14e: 386DX-40 Motherboard Octek Jaguar V. 386DX40 MB Jaguar Motherboard.

(2005, November 20). Retrieved May 3, 2016, from

https://commons.wikimedia.org/wiki/File:386DX40_MB_Jaguar_V.jpg)

The Octek Jaguar V motherboard from 1993. This board has few onboard peripherals, as evidenced by the 6 slots provided for ISA cards and the lack of other built-in external interface connectors”386DX40

Central Processing Unit (CPU)

This is seen as the brain of every computer and that is why every computer must have it. Its main purpose is to perform data processing operations.

The CPU also stores data, intermediate results and and the program (instructions). The CPU is also the part of the computer that controls the operations of all parts of the computer (Adapted from Central Processing Unit. (n.d.). Retrieved May 3, 2016, from http://www.tutorialspoint.com/computer_fundamentals/computer_cpu.htm)

The CPU in most models is as shown in the diagrams below.



Figure 1.8: "Intel 80486DX2 top".(Adopted from Intel 80486- CPU. (2005, November 09).

Retrieved May 3, 2016, from https://commons.wikimedia.org/wiki/File:Intel_80486DX2_bottom.jpg

Creative Commons Attribution-Share Alike 2.0 Generic)

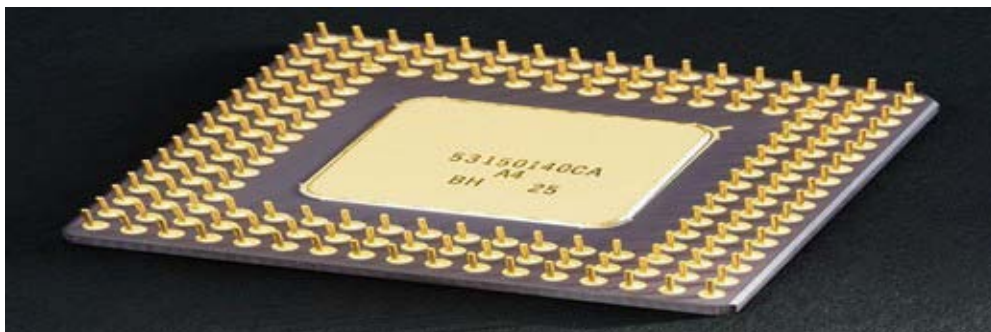

Figure 1.9: "Intel 80486DX2 bottom".

(Adopted from Intel 80486- CPU. (2005, November 09). Retrieved May 3, 2016, from [https:// commons.wikimedia.org/wiki/File:Intel_80486DX2_bottom.jpg](https://commons.wikimedia.org/wiki/File:Intel_80486DX2_bottom.jpg)

Creative Commons Attribution-Share Alike 2.0 Generic)

As mentioned earlier, the CPU being the brain of the computer, has to have all instructions pass through it to be processed.. In most literature, the CPU is simply referred to as the processor.

A typical CPU has the following components as shown in Figure 1.10.

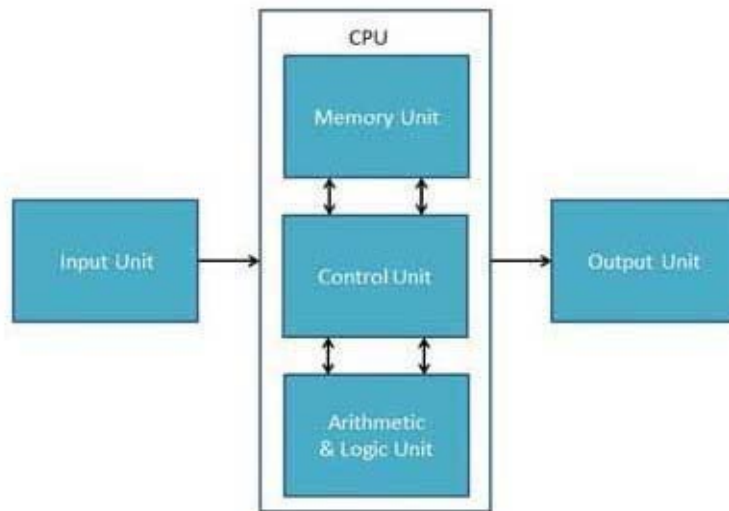

Figure 1.10 The Central Processing Unit

Source: http://www.tutorialspoint.com/computer_fundamentals/computer_cpu.htm

1. The first component is the combinational logic that is composed of two parts.

- The arithmetic section- This section is the one responsible for arithmetic operations such as addition, subtraction, multiplication and division. If there are complex operations, repetitive use of these operations is done.
- The logic section that deals with logic operations like comparison, making selections and merging data. It gets as input the operands (data words to be processed), it also receives the status information from previous operations, and a code from the control unit indicating which operation to perform. _

2. The second is the control unit (CU), and this is the manager of the components of the computer. This unit, though is the manager, does not carry out any processing itself. The following are its important functions ((Adapted from Central Processing Unit, Retrieved May 3, 2016, from http://www.tutorialspoint.com/computer_fundamentals/computer_cpu.htm)

- It is responsible for controlling the transfer of data and instructions among other units of a computer.
- It manages and coordinates all the units of the computer.
- It obtains the instructions from the memory, interprets them, and directs the operation of the computer.
- It communicates with Input/ Output devices for transfer of data or results from storage.
- It does not process or store data.

To control the other components, the control unit makes use of electrical signals. It communicates with both the Arithmetic Logic Unit and the memory. The unit is the one responsible for reading and interpreting instructions obtained from the memory and thereafter converts them into a series of signals that will be used to activate the other parts of the computer.

3. The third is the cache (registers), which serves as high-speed memory where instructions can be copied to and retrieved. Modern CPUs have been constructed as a single integrated unit called a microprocessor. As such, a CPU is a specific type of microprocessor. The individual

components of a CPU have become so integrated that you can't even recognize them from the outside.

(Adapted from Central Processing Unit, Retrieved May 3, 2016, from http://www.tutorialspoint.com/computer_fundamentals/computer_cpu.htm)

The CPU is connected to the rest of the system through system bus. Through system bus, data or information gets transferred between the CPU and the other component of the system. The system bus may have three components (Adopted from Introduction to the CPU, Retrieved May 3, 2016, from http://nptel.ac.in/courses/Webcourse-contents/IIT-Guwahati/comp_org_arc/msword/m5_CPU_Design/1_intro_to_cpu.txt)

- 1.Data bus is used to transfer the data between main memory and CPU.
- 2.Address bus is used to access a particular memory location by putting the address of the memory location.
- 3.Control Bus: Control bus is used to provide the different control signal generated by CPU to different part of the system.

These interconnections will be discussed in unit 3- Computer Organization.

The CPU is about two inches by two inches in size as in figure 1.8 and figure 1.9 .

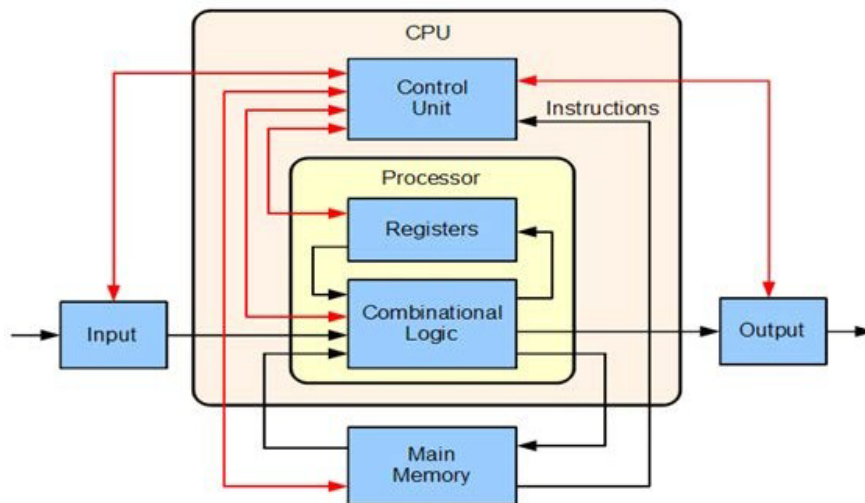

Figure 1.11: "A Basic Computer" by Lambtron

(adopted from L. (2015, January 06). A basic computer. Retrieved May 3, 2016, from <https://commons.wikimedia.org/wiki/File:ABasicComputer.gif#/media/File>

Creative Commons Attribution-Share Alike 4.0 International)

Learning Activities

Learning Activities experiment, reading and identification of components and the Interconnections

Before attempting these activities, read the following listed materials:-

1. http://www.tutorialspoint.com/computer_fundamentals/index.htm -Computer Components

2. <http://www.contentedwriter.com/function-of-computer-hardware-components/> Functions of computer hardware.

The laboratory assistant in your lab will open for you at least two different types of computers, for example, HP compaq and Dell desktop.

Repeat the same activities using HP laptop and Dell laptop. You will be expected to document the results of each activity which will form part of your learning materials. Prepare a report which you will then send to your instructor by e-mail or shared using Google drive tool.

Learning Activity 1

Activity Details: Input unit][estimated Time 1 hour]

- a. Identify the type of computers you are using.
- b. Identify and describe the features of computer input devices. If the device has its own subcomponents, identify and describe their features.
- c. Identify and locate the CPU and then describe its features.
- d. Identify and locate the output devices and then describe them. If the device has its own subcomponents, identify and describe them.

Learning Activity 2

Activity Details: Motherboard [estimated Time 1 hour]

1. Locate and describe the features of the computer motherboard.
2. Locate the following memories on the motherboard and describe their features.
 - a. Primary or main memory
 - b. Secondary memory
3. Describe the roles and functions of the following in system memory management
 - a. Registers
 - b. Cache memory
 - c. Virtual Memory
4. Locate and describe the functions of the following
 - a. Control bus
 - b. Data bus
 - c. Address bus

Learning Activity 3

Activity Details: Output [estimated Time 1 hour]

Locate and describe the following components and their positions on the motherboard

- a. hard drives,

- b. optical drives,
- c. video card
- d. sound card
- e. Southbridge
- f. Northbridge
- g. Integrated Graphics processor
- h. Connectors for peripherals, e.g keyboard, mouse, VGA, USB, etc.
- i. Systems buses / connectors/jumps
- j. System bios

Learning Activity 4

Activity Details : The bus [estimated Time1 hour]

- a. Identify and describe the PCI of the model.
- b. Repeat the activities in 1-9 for three other models.
- c. Compare the characteristics of the different types of computers you have used in the lab and describe their differences or similarities.

Conclusion for Activities 1, 2, 3 and 4

All computers share common features, each of them has input/output units. These units have different devices, each of which perform different functions. The computer uses its input unit to get data by use of input devices. The data will then be processed using the central processing unit (CPU).. The CPU has the arithmetic logic unit and the control unit. Within the CPU there are memory structures known as the registers. The processed data will then be made available to the users outside the system by use of the output unit whose devices will then be used to display the data or make the data be available to the computer user outside the system.

Assessment-Computer components

- A. What is an input unit?
- B. What do you understand by an output unit?
- C. What is the use of PCI slot?
- D. What is a port?
- E. What condition must be in place before you can connect a sound card to a motherboard?
- F. What manages and directs the flow of data between each of the components?

Different models have different types of the devices and it is good to be able to recognize these differences.

Feedback

Assessment

- A. What is an input unit? Answer: Inputs accepts data
- B. What do you understand by an output unit? Answer:Use to display results
- C. What is the use of PCI slot? Answer:Used to mount expansion
- D. What is a port? Answer:Use to attach input /output
- E. What condition must be in place before you can connect a sound card to a motherboard?

Answer: Compactable and sound card drivers

- F. What manages and directs the flow of data between each of the components? Chip set

Unit Assessment

This unit assessment will involve a laboratory work. You will then be expected to send your answers to the instructor using his/her e-mail address or shared drive. This will be graded and the grading is as given in the grading section.

Instructions

Select one model of computer in your lab, then

- a. Write down the model of the computer you have.
- b. List the input/output devices it can be connected to.
- c. Describe the features of the motherboard.
 - How many ports does the motherboard have? List them and describe them.
 - How many PCI does it have?
- d. What is the speed of the processor?

Unit Summary

In this unit, you have learnt about the components and functions of a computer. Those different models have different features of some common components. Every computer has an input unit which uses various input devices to enable the computer to receive data from outside the system. There is also the output unit that uses various output devices to make processed data to be available for users of the computer to view/use them. The central processing unit is the brain of the computer and any data that gets into the computer is processed in this section. The CPU has the ALU and the control unit whose functions have been described in the unit. All these components are connected together to form a system by using a motherboard. It enables the various units to communicate with each other. The memory unit is the store of data. In the next section, you will learn about the architecture of these parts.

Unit Readings and Other Resources

The readings in this unit are to be found at course level readings and other resources.

1. http://www.tutorialspoint.com/computer_fundamentals/index.htm -Computer Components
2. <http://www.contentedwriter.com/p1-explain-the-function-of-computer-hardware-components/> - Explain the functions of computer hardware
3. http://wikieducator.org/Caribbean_Secondary_Education_Certificate_-_Information_Technology/Functions_of_Hardware_Components_of_a_Computer_System -Caribbean Secondary Education Certificate - Information Technology/Functions of Hardware Components of a Computer System
4. http://en.wikipedia.org/wiki/Computer_architecture- Computer architecture
5. http://www.mpsaz.org/eva/staff/ksrandle/class1/files/motherboard_labels.pdf- labeled diagram of a motherboard.
6. http://simple.wikipedia.org/wiki/Computer_architecture - computer architecture

Unit 3: Micro Architecture

Introduction

In this unit, you will learn about the organization of the computer, the part of computer architecture that defines the data paths, data processing and storage elements, as well as how these elements should be implemented in the ISA discussed in the other units. Computer instructions are composed of an operation code, also known as opcode, and one or more operands. An operand is something which is acted on by the operation. It can be a constant value, a register identification code, or the address of a location in memory or of an I/O device.

You already know that computers only understand binary of 1's and 0's. The simplest instruction, opcode, is known as the machine code and is executed directly by the CPU. This machine code allows the computer to perform very basic but essential tasks. The results of these instructions are stored in a register known as accumulator.

Unit Objectives

Upon completion of this unit you should be able to:

1. Explain the structure of the interconnection structures of the computer.
2. Explain how control unit interprets a machine-level instruction – either directly or as a micro program.
3. Identify internal operations of a computer

Key Terms

An **address bus** is a computer bus (a series of lines connecting two or more devices) that is used to specify a physical address.

Data bus is an internal pathway across which data are transferred to and from the processor or to and from memory (<http://www.pcmag.com/encyclopedia/term/40745/data-bus>)

A **program counter** is a register in a computer processor that contains the address (location) of the instruction being executed at the current time. As each instruction gets fetched, the program counter increases its stored value by 1. After each instruction is fetched, the program counter points to the next instruction in the sequence. When the computer restarts or is reset, the program counter normally reverts to 0. (<http://whatis.techtarget.com/definition/program-counter>)

In a computer, **the Memory Address Register (MAR)** is a CPU register that either stores the memory address from which data will be fetched to the CPU or the address to which data will be sent and stored. In other words, MAR holds the memory location of data that needs to be accessed. (https://en.wikipedia.org/wiki/Memory_address_register)

The Memory Data Register (MDR) or Memory Buffer Register (MBR) is the register of a computer's control unit that contains the data to be stored in the computer storage (e.g. RAM), or the data after a fetch from the computer storage. (https://en.wikipedia.org/wiki/Memory_data_register)

In computing, **an instruction register (IR)** is the part of a CPU's control unit that stores the instruction currently being executed or decoded. (https://en.wikipedia.org/wiki/Instruction_register)

Introduction

As explained in Unit 1, functional components of a computer system include input unit, central processing unit and the output unit. These units are connected through the motherboard as explained in unit 1. There are a variety of interconnection structures that have been designed and in use, but the most common is the bus and various multiple-bus structures. An important feature of the bus is that it is a shared transmission medium where more than one device can be connected to it. The moment a device is connected a signal is then transmitted and is received by all the devices connected to the bus.

The transmission is such that only one device at a time can do the transmission. This is to avoid confusion which may result if more than one device is allowed to transmit. In modern computers, a bus consists of multiple pathways, known as lines, that are used to transmit signals. A system bus may at times have about 50 to 100 separate lines where each line is dedicated to a specified function or has a particular meaning. For example, there are three functional groups which are data, address and control lines.

The diagram below shows such a structure and the functional groups.

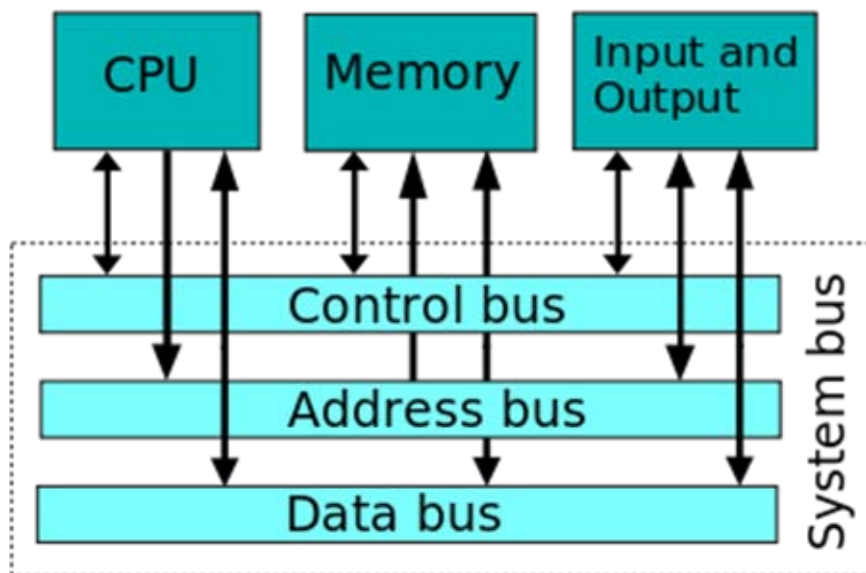

Figure 3.1-computer Bus:

Available at: http://en.wikipedia.org/wiki/System_bus. The data bus, also known as data lines, may have 32, 64, 128 or even more such separate lines. The number of lines represents the width of the data bus. Here, a data line can only carry 1 bit at a time and therefore, the number of lines is an indicator of how many bits can be transferred at a time. The other group of lines is the address bus (lines) and are used to show the source or the destination on the data bus. The width of the address bus is used to determine the memory capacity of the system.

The other group is the Clock control lines which are used to synchronize operations and initialize all modules.

In case the CPU or the memory or the I/O wants to transmit data, there are two important things that must occur. The use of the bus must be requested and obtained and that the data must be transferred via the bus address lines.

Learning Activities

Before doing this activity, you are to read the following materials as listed below [10 hours]

1. http://www.tutorialspoint.com/computer_fundamentals/index.htm- Computer Fundamentals- (Read from computer types to computer hardware)
2. http://simple.wikipedia.org/wiki/Computer_architecture - computer architecture
3. http://en.wikiversity.org/wiki/Computer_architecture_and_organization - Computer architecture and organization

You will also spend some time, about seven hours, to look for related materials in order to competently complete the activities given here in this module.

Activity 1

Activity Details : Interconnection structures - The Bus [5 hours]

In this activity, you are to open at least two computers of different computer architecture models complete the following:-

1. Name the computer architecture widely used by modern computers
2. From the computer architecture model you are using identify the following:
 - a) Number of data buses
 - b) Number of address buses
 - c) Number of control buses
3. Identify the type of connection for each I/O device and list the type of connection, e.g ISA, PCI, USB, COM port, etc.
4. Indicate what kind of data each of the I/O devices may send through the data bus.

Conclusion

There are different buses, input/output devices, ports, USB, COM ports and that these are different for different computer architecture models and that some are standard like ports, USB, COM ports.

Instruction cycle (The Fetch-Execute Cycle)

Introduction

This is the process where a computer retrieves program instructions from its memory, examines them and determines what actions the instructions requires and eventually executes (performs) those actions. This activity is repeated from the time the computer is switched on to when it is switched off. This process is sequential in that each instruction is processed to completion before another one is started. In modern machines, there are concurrent executions where instructions are processed in parallel.

Central Processing Units (CPUs) have different instruction cycles because of different instruction sets. Instruction Cycle, “ Instruction Cycle. Web. 15 Mar. 2016. Available at http://www.digplanet.com/wiki/Instruction_cycle

The implementation of what has been described here in the fetch and execute cycle will be discussed in unit 4, Instruction Set Architecture (ISA).

Essential Registers for Instruction Execution

There are four registers that are essential to instruction execution and they are:- (Adopted from Introduction to the CPU, Retrieved May 3, 2016, from [http://nptel.ac.in/courses/Webcourse-contents/IIT- and W. S. \(n.d.\)](http://nptel.ac.in/courses/Webcourse-contents/IIT- and W. S. (n.d.)). Computer functions and interconnections. Retrieved May 4, 2016, from <http://www.guswnsla1223.tistory.com/attachment/cfile29.uf@153C97234AE9564A37B69E.pdf>

copyright @2005)

- Program Counter (PC)- This register contains the address of an instruction that is to be fetched. The program counter is typically incremented (made to point to the next instruction) once a given instruction has been fetched. The PC, therefore, will always point at the next instruction to be fetched.
- The Instruction register (IR)- This is the register that contains the most recently fetched instruction. The opcode (operation code) and operand specifies are analyzed once the fetched instruction is loaded onto the IR.
- The memory address register (MAR)-this register holds the address of a location of the main memory from where the information is to be fetched or stored. The contents of this memory is directly connected to the address bus.
- The memory buffer register (MBR)-This register contains a word of data to be written to the main memory or that it contains the word that was most recently read. The contents of this register are directly connected to the data bus.

Apart from the above dedicated registers, there are temporary registers that are not visible to the user and only serve as input/output registers for the arithmetic logic unit (ALU). They exchange data with MBR and user visible registers.

Program Execution

The instructions that form a program to be executed are loaded onto the main memory in sequential locations (Adopted from Introduction to the CPU, Retrieved May 3, 2016, from <http://nptel.ac.in/courses/Webcourse-contents/IIT->). To execute this program, the central processing unit is then to fetch the instructions one after the other. It will then decode the instructions and thereafter performs the actions required. The detailed actions are described below for each of the stages of the fetch-decode and execute sequence.

The instruction must be fetched and loaded to the instruction register. The instruction is expected to contain bits that details the actions that are to be performed by the processor.

The processor is then expected to interpret the instruction to know the actions that are to be done. In general, the actions that can be performed can be grouped into four categories(Adopted from Introduction to the CPU, Retrieved May 3, 2016, from <http://nptel.ac.in/courses/Webcourse-contents/IIT->). They are:-

- Processor-memory: This is where data is transferred from processor to memory or from the memory to the processor.
- Processor-I/O: This is where data may be transferred to/from a peripheral device and is to be done by transferring between the processor and the module that

deals with the input/output.

- Data processing: Arithmetic or logic operations may be performed on the data.
- Control: There could be an instruction that may make a specification that the sequence of the executions of the actions may be changed.

You will notice that the main task will consist of changing from fetching the instruction and the execution of the actions associated with the instruction. The instruction must be examined to establish if there are any indirect addressing that may be involved. If there is one, then the operands that may be involved must be fetched using the indirect addressing mode. It should also be mentioned that the performance of actions associated with a given instruction (execution of the instruction) may require more than one reference to memory. In some cases, an instruction may include a specification of an input/output operation.

The fetch and execute can be seen as a state of activities that is composed of the steps explained below, some states may be null while others may be done more than once (Adopted from Introduction to the CPU, Retrieved May 3, 2016, from <http://nptel.ac.in/courses/Webcourse-contents/IIT-> and also in <http://cs323.wikispaces.com/file/view/Ch3.pptx>).

- Instruction Address Calculation (IAC): This is a state where the address of the next instruction is calculated and this normally involves changing the program counter by adding a fixed number of the address of the previous instruction.
- Instruction Fetch (IF): This is the state where the instruction is read from the memory location into the processor.
- Instruction Operation Decoding (IOD): This is the state where analysis is done to establish the type of operation to be performed and the operands that are involved.
- Operand Address Calculation (OAC): This one here determines the address of the memory if the operation is to use an operand.
- Operand Fetch (OF): This one is for fetching the operand from memory and have it read from the input/output.
- Data Operation (DO): This is the state where the operation is performed as indicated in the instruction.
- Operand Store (OS): This is the state where the result of the action is written into the memory or taken out to the I/O. (Computer functions and interconnections.
- Retrieved May 4, 2016, from <http://www.guswnsla1223.tistory.com/attachment/cfile29.uf@153C97234AE9564A37B69E.pdf> copyright @2005)

The implementation of the sequence is also given in unit 4 and you are encouraged to understand the actions that form the steps of the sequence.

1 .Detailed actions in the Fetch the Instruction

The first step of the Instruction Cycle is called the Fetch instruction Cycle. The Control Unit fetches the instruction's address from the memory unit using following the steps:

(Adapted from Instruction Cycle." Instruction Cycle. Web. 15 Mar. 2016. Available at http://www.digplanet.com/wiki/Instruction_cycle and <http://web.cse.ohio-state.edu/~reeves/CSE2421au12/SlidesDay35.pdf>)

- a. The CPU sends PC to the MAR and sends a READ command on the control bus

- b. In response to the read command (with address equal to PC), the memory returns the data stored at the memory location indicated by PC on the data bus.
- c. The CPU copies the data from the data bus into its MDR
- d. A fraction of a second later, the CPU copies the data from the MDR to the Instruction Register (IR)
- e. The PC is incremented so that it points to the next instruction in memory. This step prepares the CPU for the next cycle.

2 .Detailed actions in the Fetch phase

(ComputerArchitecture: Fetch and execute cycle adopted and available at <http://www.inf.uni-konstanz.de/dbis/teaching/ws0304/computing-systems/download/rs-02.pdf> and (Adopted from Introduction to the CPU, Retrieved May 3, 2016, from [http://nptel.ac.in/courses/Webcourse-contents/IIT- \)](http://nptel.ac.in/courses/Webcourse-contents/IIT-)))

- a. The address in the CPU register IP is transmitted via the address bus to the memory unit's MAR: (IP points at individual bytes [= 8 bits] in memory):

IP→MAR
- b. IP is incremented to point at the next program instruction, ready for the next cycle

P +1+
- c. Memory selects addressed location and copies its contents onto the data bus; CPU loads received data into IR:

(MAR) → IR
- d. CPU starts decoding the instruction in IR

(Available at <http://web.cse.ohio-state.edu/~reeves/CSE2421au12/SlidesDay35.pdf>)

3 .Detailed actions in the Decode the Instruction

The decoding process allows the CPU to determine what instruction is to be performed, so that the CPU can tell how many operands it needs to fetch in order to perform the instruction. The opcode fetched from the memory is decoded for the next steps and moved to the appropriate registers. The decoding is done by the CPU's Control Unit. (Adapted from Instruction Cycle." Instruction Cycle. Web. 15 Mar. 2016. Available at http://www.digplanet.com/wiki/Instruction_cycle and <http://web.cse.ohio-state.edu/~reeves/CSE2421au12/SlidesDay35.pdf>)

4 .Detailed actions in the Read the effective address

Read instruction cycle is in deciding which operation it is. If this is a Memory operation - in this step the computer checks if it's a direct or indirect memory operation:

- Direct memory instruction - Nothing is being done.
- Indirect memory instruction - The effective address is being read from the memory.

If this is a I/O or Register instruction - the computer checks its kind and executes the

instruction.

(adapted from Instruction Cycle.” Instruction Cycle. Web. 15 Mar. 2016. Available at http://www.digplanet.com/wiki/Instruction_cycle , <http://web.cse.ohio-state.edu/~reeves/CSE2421au12/SlidesDay35.pdf> and ((Adopted from Introduction to the CPU, Retrieved May 3, 2016, from <http://nptel.ac.in/courses/Webcourse-contents/IIT->.)

5 .Detailed actions in the Execute the Instruction

Execute cycle is where the action of the instruction is performed. If the instruction involves arithmetic or logic, the Arithmetic Logic Unit is utilized. This is the only stage of the instruction cycle that is useful from the perspective of the end user. Everything else is overhead required to make the execute stage happen.

(adapted from Instruction Cycle.” Instruction Cycle. Web. 15 Mar. 2016. Available at http://www.digplanet.com/wiki/Instruction_cycle , <http://web.cse.ohio-state.edu/~reeves/CSE2421au12/SlidesDay35.pdf> and ((Adopted from Introduction to the CPU, Retrieved May 3, 2016, from <http://nptel.ac.in/courses/Webcourse-contents/IIT->.)

6 .Detailed actions in the Store the Result in Memory

The last final instruction cycle is where the result is stored the result in a register or in memory, if there is one. The program is then updated to hold the next instruction location, which is either the next memory location or the address specified by a branch instruction. (adapted from Instruction Cycle.” Instruction Cycle. Web. 15 Mar. 2016. Available at http://www.digplanet.com/wiki/Instruction_cycle and <http://web.cse.ohio-state.edu/~reeves/CSE2421au12/SlidesDay35.pdf> and (Adopted from Introduction to the CPU. Retrieved May 3, 2016, from <http://nptel.ac.in/courses/Webcourse-contents/IIT->)

Activity 2

Activity details :- Reflection Activity Instruction cycle(The Fetch-Execute Cycle) [5 hours] In this activity, you are to describe the functions of the following in the fetch-execute cycle:

- a. Program counter
- b. Memory address register (MAR)
- c. Memory data register (MDR)
- d. Instruction register (IR)
- e. Arithmetic Logic Unit (ALU)
- f. Control Unit (CU)

You may wish to refer to your notes and /or materials you found in unit 1. Prepare brief notes on these.

Activity 3

Activity details: Instruction cycle(The Fetch-Execute Cycle) [3 hour]

In this activity you are to identify and describe the characteristics the following in fetch decode execute cycle, provide 3 examples for each of them from different sources.

- a. Direct memory instruction
- b. Indirect memory instruction

Conclusion

The fetch, decode, execute and store instructions are the steps that must be followed during data processing and you have learnt how step is implemented.

Unit Assessment

1. Where does the Instruction cycle take place ?
2. Why does data need to be fetched? Isn't it okay where it is?
3. Describe the stages of the fetch-execute cycle, stating the components involved and their functions in the cycle.
4. Explain how the computer keep track of instructions?
5. Where does the computer put the instruction it has just fetched?

Feedback

The answers to these questions are found in the notes. Find them, compile and send them to your instructor e-mail address.

Unit Summary

In this unit, you have been able to comprehend the structure of the interconnection structures of the computer. You can now explain how a CPU's control unit interprets a machine-level instruction – either directly or as a microprogram. You can use register transfer language to describe internal operations in a computer system.

Unit Readings and Other Resources

The readings in this unit are to be found at course level readings and other resources.

1. <http://www.cise.ufl.edu/~mssz/CompOrg/CDA-lang.html> Organization of Computer Systems: ISA, Machine Language, and Number Systems
2. http://en.wikibooks.org/wiki/A-level_Computing/AQA/Computer_Components,_The_Stored_Program_Concept_and_the_Internet/Machine_Level_Architecture/Machine_code_and_processor_instruction_set Machine Level Architecture: Machine code and processor instruction set
3. http://teaching.idallen.com/dat2343/10f/notes/410_MachineLevelInstructions.html Machine Level instructions in the General mode.
4. www.csie.nuk.edu.tw/.../Chapter2_Instr... Chapter 2 Instructions: Language of the Computer

Unit 4: Instruction Set Architecture (ISA)

4

Introduction

In this unit, you will learn about Instruction Set Architecture. This is the part of the central processing unit that is visible to the programmer who writes the compiler instructions.

Each type of central processing unit is designed to understand a specific group of instructions called the instruction set. This set has an architecture known as instruction set architecture (ISA). An instruction set architecture (ISA) is the interface between the computer's software and hardware and also can be viewed as the programmer's view of the machine as in it defines the codes that a central processor reads and acts upon. An interface is a shared boundary across which two separate components of computer system exchange information. The exchange can be between software, computer hardware, peripheral devices, humans and combinations of these. (see D. D. (2007, November). Computer Systems 113 Architecture 110. Retrieved April 12, 2016, from http://www.doc.ic.ac.uk/~eedwards/compsys/0_Notes2_MemoryCPU.doc and in Instruction set explained in, retrieved April 12, 2016, from http://everything.explained.today/Instruction_set/).

The instruction set architecture is an interface but for microprocessors. It particularly concerns itself with the following issues:-

1. What operations can be performed by the computer? This is the instruction set.
2. How are the instructions specified? This one is known as instruction format.
3. Where is the data to be processed located? This is the data storage.
4. How can the data be accessed? This is the addressing mode

In this unit, you will learn how the above concerns are dealt with at the microprocessor interface.

Unit Objectives

Upon completion of this unit you should be able to:

1. Identity key operations that a computer can perform
2. Describe how Instructions are specified.
3. Explain where data is stored in a computer system
4. Explain different addressing modes for accessing stored data
5. Design and implement machine instructions

Key Terms

An instruction set architecture (ISA) is the interface between the computer's software and hardware and also can be viewed as the programmer's view of the machine. It defines the codes that a central processor reads and acts upon

An interface is a shared boundary across which two separate components of a computer system exchange information. The exchange can be between software, computer hardware, peripheral devices, humans and combinations of these. Some computer hardware devices such as a touchscreen can send and receive data through the interface, while others such as a mouse, microphone or joystick are one way only.

An assembly language is a low-level programming language for a computer, or other programmable device, in which there is a very strong (generally one-to-one) correspondence between the language and the architecture's machine code instruction

A memory address is a unique identifier used by a device or CPU for data tracking. This binary address is defined by an ordered and finite sequence allowing the CPU to track the location of each memory byte. Memory addresses are usually allocated during the boot process.

Addressing modes are an aspect of the instruction set architecture in most central processing unit (CPU) designs. The various addressing modes that are defined in a given instruction set architecture define how machine language instructions in that architecture identify the operand (or operands) of each instruction. An addressing mode specifies how to calculate the effective memory address of an operand by using information held in registers and/or constants contained within a machine instruction or elsewhere.

A load/store architecture only allows memory to be accessed by load and store operations, and all values for an operation need to be loaded from memory and be present in registers. Following the operation, the result needs to be stored back to memory. For instance, in a load/store approach both operands for an ADD operation must be in registers.

A register memory architecture allows operations to be performed on memory, as well as registers. In this approach one of the operands for ADD operation may be in memory, while the other is in a register

A compiler is a program that translates a source program written in some high-level programming language into machine code for some computer architecture (such as the Intel Pentium architecture Machine Language Instructions)

What Instructions can be performed (machine language instructions)

Instructions are words of a language that are understood by a machine. They are a set of binary codes that are used to direct the activities of the Central processing unit (CPU).

There are three different types of instructions which are:-

a. Data movement instructions

- The Load instruction has the source being the memory and destination being the register
- The Store instruction has the source being register and destination being memory

b. Arithmetic and logic (ALU) instructions. These are the

Add, Sub, Shift, etc.

- Branch instructions (control flow instructions)
- These are the unconditional or conditional branches

Each of these instructions must have a format and depends on the machine you are using. An instruction format or instruction code is a group of bits used to perform a particular operation on the data stored in a computer. Processor fetches an instruction from memory and decodes the bits to execute the instruction. Different computers may have their own instruction set.

An instruction is normally made up of a combination of an operation code and some way of specifying an operand, most commonly by its location or address in memory.

Some operation codes deal with more than one operand; the locations of these operands may be specified using any of the many addressing schemes. Different machines have different instruction set architectures. These architectures are differentiated from one another by the number of bits allowed per instruction (16, 32, and 64 are the most common).

Instruction Format

The instructions are 16 bit and this so that they can fit into main memory word. The instruction is divided into a number of instruction fields that represents a different information for the CPU. Each instruction has a format that is consist of operation code (OPCODE) and in some cases, operands. The commonly used format is of the form as shown below

Memory Address	Machine Codes	Labels	Mnemonics	Operands	Comments
----------------	---------------	--------	-----------	----------	----------

Adapted from Instruction Format.(Retrieved April 13, 2016, from <http://gradestack.com/Microprocessors-and/Assembly-Language/Instruction-Format/19312-3912-38125-study-wtw> grade stack

1. **Memory address** -is the where the program or instruction is stored.
2. **Machine codes** -are the hexadecimal representation of operation codes
3. **Labels-** is optional and it provides a symbolic name of branch instructions of the instructions; it is normally used for conditional/unconditional jumping.
4. **Mnemonics** states the operation to beexecuted.
5. **Operands** -for one byte instruction there is no operand, for two byte instruction there is one operand and for a three byte instruction there are two operands separated by a comma.

Addressing Modes

There are different fundamental addressing modes

1. Direct Addressing mode (also called Absolute Addressing)
2. Indirect addressing mode
3. Index Addressing mode
4. Relative addressing mode
5. Autoincrement addressing Mode
6. Auto-decrement addressing mode

(available in Saleh, S. M. (2013, January 17). http://www.uobabylon.edu.iq/eprints/pubdoc_1_15253_37.doc. Addressing Modes.

Direct (Absolute) Addressing Mode

In this kind of instruction, the source operand represent the value stored in the location whose address is given, 30h. It will then store in the accumulator A. The instruction is then given as MOV A,30h. You can see that it follows the format “ Opcode Effective Address of Operand” described at Saleh, S. M. (2013, January 17). http://www.uobabylon.edu.iq/eprints/pubdoc_1_15253_37.doc.

Addressing modes

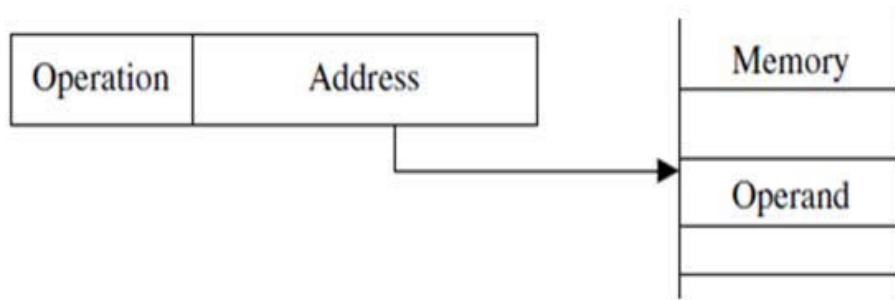

Figure 4.2: Illustration of Direct Addressing Mode.

Adopted and retrieved from instruction set architecture and design available at <http://www.slideshare.net/srisumandas/2instruction-set-architecture-design>

Indirect Addressing Mode

Indirect mode holds memory location of effective address of the operand.

For example, the instruction LOAD (1000), Ri, this instruction has the memory location 1000 enclosed in parentheses, thus indicating indirection. The meaning of this instruction is to load register Ri with the contents of the memory location whose address is stored at memory address 1000. There are two types of indirect addressing.

1. Register indirect addressing: A register is used to hold the address of the operand,
2. Memory indirect addressing: A memory location is used to hold the address of the operand. The two types are illustrated in figure 4.3

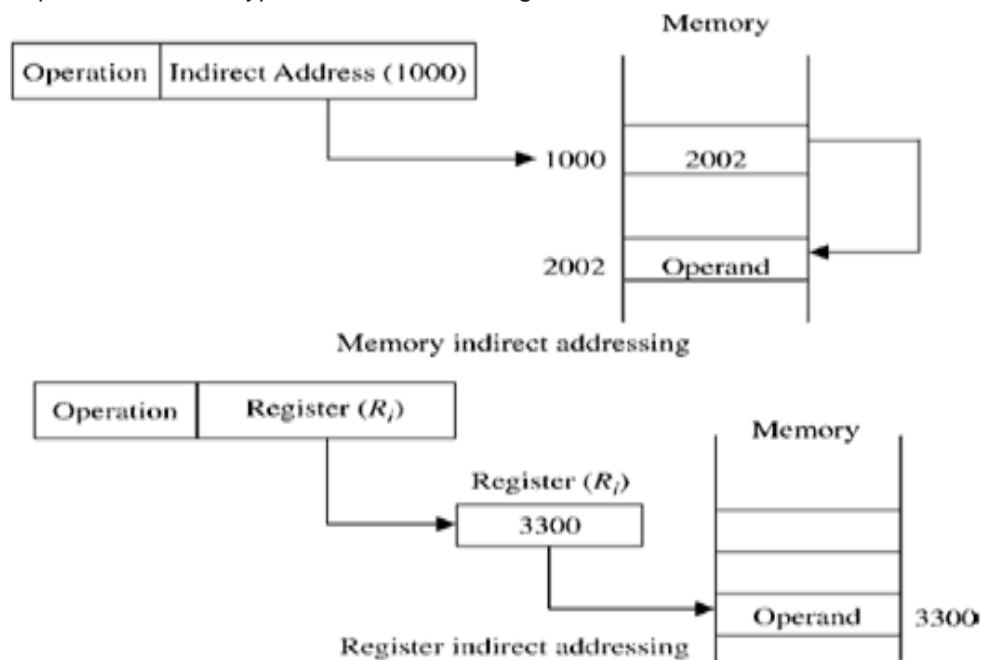

Figure 4.3: Indirect addressing mode Illustration.

Adopted and retrieved from instruction set architecture and design available at <http://www.slideshare.net/srisumandas/2instruction-set-architecture-design>

Indexed Addressing Mode

In this addressing mode, the address of the operand is obtained by adding a constant to the content of a register, called the index register. Consider, for example, the instruction LOAD X(Rind), Ri. This instruction loads register Ri with the contents of the memory location whose

address is the sum of the contents of register (R_{ind}) and the value X . Index addressing is indicated in the instruction by including the name of the index register in parentheses and using the symbol X to indicate the constant to be added. Indexing requires an additional level of complexity over register indirect addressing.

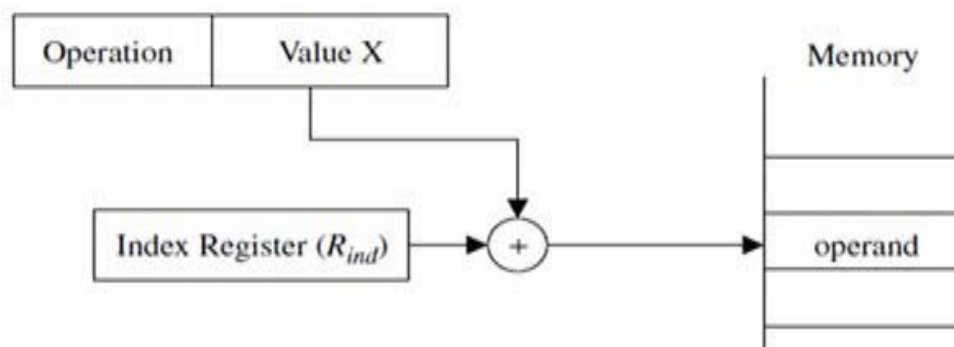

Figure 4.4 Indexed addressing mode Illustration

Adopted and retrieved from instruction set architecture and design available at <http://www.slideshare.net/srisumandas/2instruction-set-architecture-design>

Relative Addressing Mode

Relative addressing is the same as indexed addressing except that the program counter (PC) replaces the index register.

For example, the instruction $LOAD\ X(PC), R_i$ loads register R_i with the contents of the memory location whose address is the sum of the contents of the program counter (PC) and the value X . Figure 18 illustrates the relative addressing mode.

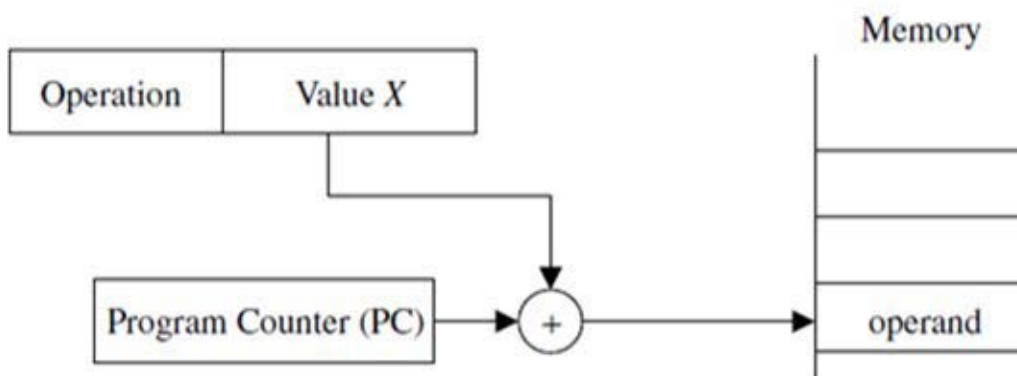

Figure 4.5: Relative Addressing Mode;

Adopted and retrieved from instruction set architecture and design available at <http://www.slideshare.net/srisumandas/2instruction-set-architecture-design>

Auto Increment Addressing Mode

The content of the autoincrement register is incremented after accessing the operand. The automatic increment of the register's content after accessing the operand is indicated by including a $(+)$ after the parentheses.

For example, the instruction $LOAD\ (R_{auto})+, R_i$. This instruction loads register R_i with the operand whose address is the content of register R_{auto} . After loading the operand into register R_i , the content of register R_{auto} is incremented, pointing for example to the next item in a list of items. Figure 19 illustrates the autoincrement addressing mode.

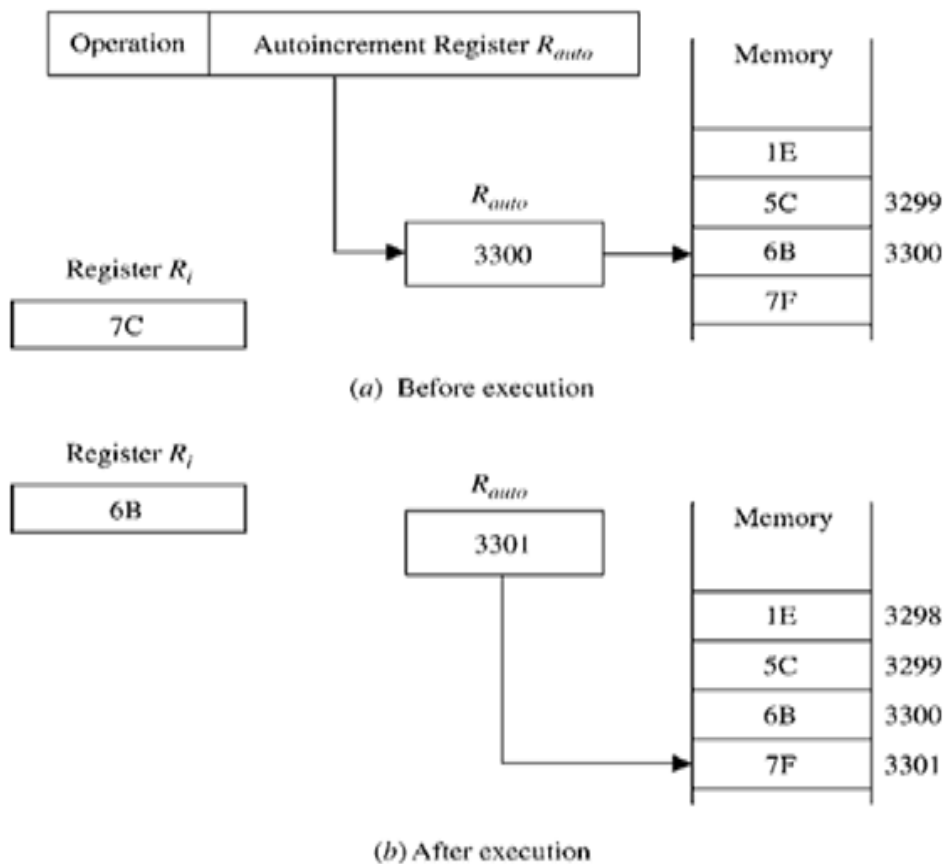

Figure 4.6 : Autoincrement addressing mode;

Adopted and retrieved from instruction set architecture and design available at <http://www.slideshare.net/srisumandas/2instruction-set-architecture-design>

Auto-decrement Addressing Mode

The auto decrement mode uses a register to hold the address of the operand. The content of the auto decrement register is first decremented and the new content is used as the effective address of the operand. The content of the auto decrement register is decremented before accessing the operand, a (—) is included before the indirection parenthesis .

For example, the instruction LOAD (R_{auto}), R_i . This instruction decrements the content of the register R_{auto} and then uses the new content as the effective address of the operand that is to be loaded into register R_i . (Adopted and retrieved from - Instruction set Architecture available at <http://www.slideshare.net/srisumandas/2instruction-set-architecture-design>)

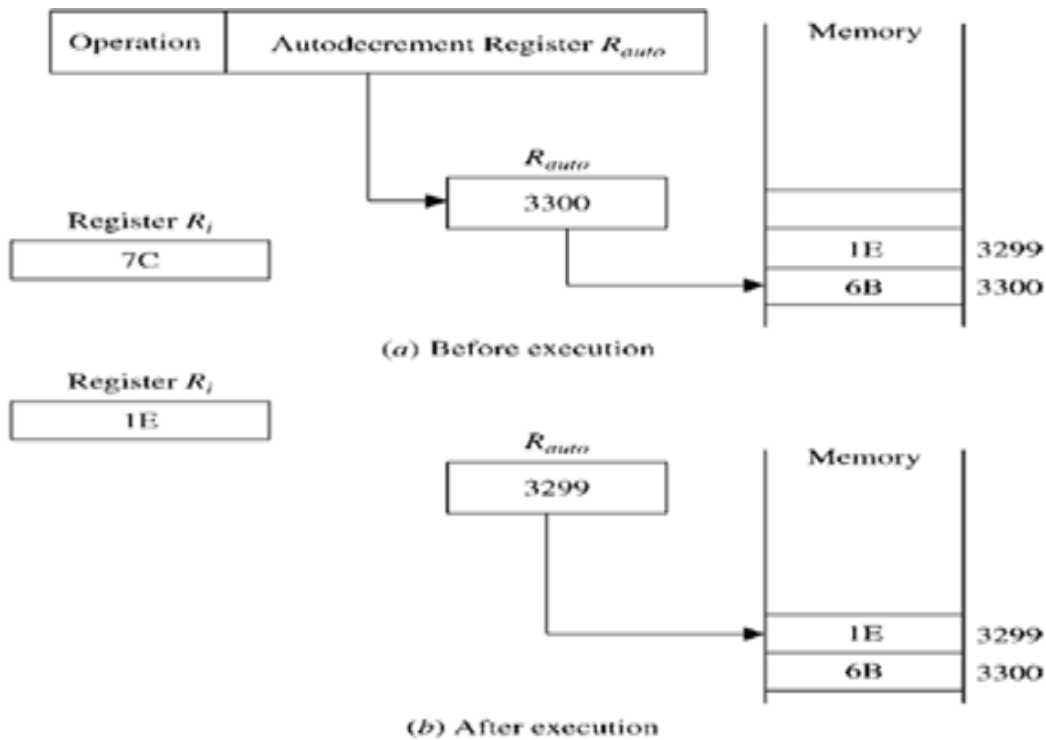

Figure 4.7 Auto Decrement Addressing Mode Illustration;

Learning Activities

Learning Activity 1

Activity Details:- Direct Addressing mode [1 hour]

Before doing this activity, you are asked to read the following topics in the listed reading materials.

1. JOHN DAINITH. "instruction format." A Dictionary of Computing. 2004. Encyclopedia.com. 12 Mar. 2016 <<http://www.encyclopedia.com>>.
2. https://en.wikibooks.org/wiki/A-level_Computing/AQA/Computer_Components,_The_Stored_Program_Concept_and_the_Internet/Machine_Level_Architecture/Machine_code_and_processor_instruction_set -Machine level architecture: Machine and processor instruction set http://www.personal.kent.edu/~aguercio/CS35101Slides/Tanenbaum/CA_Ch05_PartII.pdf- Common Instruction Formats.
3. <http://www.kuroski.net/CS221-01/addressing%20modes.doc>- addressing modes

In this activity, you will practice how to write direct addressing mode instruction. At the end of each, you will be able to write your own instructions by following the details of each activity.

1. Write machine instructions to compare the two numbers in R1 and R2, and then put the value

- a. 0 in R0 if $R1 = R2$,
- b. 1 if $R1 > R2$,
- c. -1 if $R1 < R2$.

Finally, store the result to memory location 0x4000.

Learning Activity 2

Activity Details - Indirect Addressing Modes (how is data accessed?) [1 hour]

Before doing this activity, you are asked to read the following topics in the listed reading materials.

1. JOHN DAINITH. "instruction format." A Dictionary of Computing. 2004. Encyclopedia.com. 12 Mar. 2016 <<http://www.encyclopedia.com>>.
2. https://en.wikibooks.org/wiki/A-level_Computing/AQA/Computer_Components,_The_Stored_Program_Concept_and_the_Internet/Machine_Level_Architecture/Machine_code_and_processor_instruction_set -Machine level architecture: Machine and processor instruction set
3. <http://www.slideshare.net/srisumandas/2instruction-set-architecture-design>- Instruction set architecture and design (sections 2.1 to 2.3.2)
4. http://www.personal.kent.edu/~aguercio/CS35101Slides/Tanenbaum/CA_Ch05_PartII.pdf-
5. <http://www.kuroski.net/CS221-01/addressing%20modes.doc>- addressing modes

Activity Procedure

1. Rewrite the following sequence of code using the register and register indirect addressing modes:

1. LOAD r1, (200)
2. ADD r3, r2, 10(r1)
3. AND r3, r2, @r2

Answer

1. LOAD r1, 200# immediate;
2. LOAD r1, (r1)# register indirect
3. ADD r4, r2, 10# these two instructions replace the
4. ADD r3, r2, r4# ADD in the above sequence
5. LOAD r4, (r2)# and the two simulate the memory
6. AND r3, r2,(r4)# indirect addressing;

2. An integer is stored somewhere in the memory; a pointer to this integer is at address 200. Show how memory indirect addressing is used to increment the number.

Answer

If the machine supports the base address (200) to be in memory we have:

1. LOAD r2, 1
2. ADD r2, r2, @(200)
3. STORE@(200), r2

Learning Activity 3

Reflective Activity details: Addressing Modes [1 hour]

Explain the differences in mode of operation of the following addressing modes

1. Register Addressing
2. Immediate Addressing
3. Direct Memory Addressing
4. Direct offset Addressing

Conclusion

You have learnt that there are various addressing modes that are involved in fetch and execute instructions, what operations to be performed, where to fetch the operands from, where to store the results, and address of the instruction to be fetched next.

Summary

Estimated time [2 hours]

1. Where is the data (operand) if the address mode specifier is:

- a. 000
- b. 001

2. Addressing mode is a way to address an operand. Operand means the data we are operating upon (in most cases source data). It can be a direct address of memory, it can be register names, it can be any numerical data etc. Explain this with a simple data move instruction of 4545 below:

```
MOV A,30h
```

3. An array of two integers (each integer = 32 bits) is placed in memory starting with address 100. Show how to increment each element of the array using register indirect addressing mode.

Unit Summary

In this unit you have learnt the concept of an instruction set architecture, ISA, and the nature of a machine-level instruction in terms of its functionality and use of resources (registers and memory). You have been able to characterize the differences between register-to-memory ISAs and load/store ISAs.

You are now able to analyze the relationship between instruction set architecture, micro architecture, and system architecture and their roles in the development of the computer.

Feedback

1. Where is the data (operand) if the address mode specifier is:

- a. 000
- b. 001

Answer

a. In the instruction specifier

b. In the place named in the instruction specifier

2. Addressing mode is a way to address an operand. Operand means the data we are operating upon (in most cases source data). It can be a direct address of memory, it can be register names, it can be any numerical data, Explain this with a simple data move instruction of 4545 below:

```
MOV A,30h
```

Answer

The data A is the operand, often known as source data. When this instruction is executed, the data 30h is moved to accumulator A. There are five different ways to execute this instruction and hence we say, we have got five addressing modes for 4545. Identify and illustrate these seven addressing modes types as explained above.

3. An array of two integers (each integer = 32 bits) is placed in memory starting with address 100. Show how to increment each element of the array using register indirect addressing mode.

Answer

- 4. LOAD r1, 100# the base
- 5. LOAD r2, 1 # 1 will be used for increment
- 6. ADD r3, r2, (r1)
- 7. STORE (r1), r3
- 8. ADD r1, r1, 4# the next array element is at 104
- 9. ADD r3, r2, (r1)
- 10. STORE (r1), r3

Unit Readings and Other Resources

The readings in this unit are to be found at course level readings and other resources.

1. www.cs.virginia.edu/~cs333/notes/cs333_class3.pdf- class 3 Instruction set Architectures, University of Virginia
2. <http://www.slideshare.net/srisumandas/2instruction-set-architecture-design>- Instruction set Architecture
3. <http://www.encyclopedia.com/doc/1O11-instructionformat.html> JOHN DAINTITH. "instruction format." A Dictionary of Computing. 2004. Encyclopedia.com. 12 Mar. 2016 <<http://www.encyclopedia.com>>.
4. <http://www.cs.umd.edu/class/sum2003/cmsc311/Notes/Mips/format.html> Instruction format
5. http://en.wikipedia.org/wiki/MIPS_instruction_set MIPS instruction set
6. http://en.wikipedia.org/wiki/Computer_architecture computer architecture
7. http://simple.wikipedia.org/wiki/Computer_architecture - computer architecture
8. http://en.wikiversity.org/wiki/Computer_architecture_and_organization - Computer architecture and organization. http://en.wikipedia.org/wiki/Computer_architecture-
9. <http://www.karbosguide.com/books/pcarchitecture/start.htm> PC Architecture a book by Michael Karbo. chapter 29
10. <http://en.wikipedia.org/wiki/Multiprocessing> multiprocessing
11. http://www.personal.kent.edu/~aguercio/CS35101Slides/Tanenbaum/CA_Ch05_PartII.pdf - common Instruction Formats.
12. https://en.wikibooks.org/wiki/A-level_Computing/AQA/Computer_Components,_The_Stored_Program_Concept_and_the_Internet/Machine_Level_Architecture/Machine_code_and_processor_instruction_set Machine_Level_Architecture/Machine_code_and_processor_instruction_set
13. http://homepage.cs.uri.edu/book/cpu_memory/http://cs.sru.edu/~mullins/cpsc100book/IntroToCS.htmlcpu_memory.htm How Computers Work: The CPU and Memory
14. http://www.tutorialspoint.com/computer_fundamentals/index.htm- Computer Fundamentals
15. http://en.wikipedia.org/wiki/Computer_architecture#Instruction_set_architecture computer architecture
16. <http://www.cs.toronto.edu/~demke/469F.06/Lectures/Lecture6.pdf>- Lecture on Interrupts (University of Toronto)
17. <http://people.freebsd.org/~jhb/papers/bsdcan/2007/article/article.html> PCI Interrupts for x86 Machines under FreeBSD
18. http://en.wikipedia.org/wiki/Instruction_set Instruction set

Course Summary

Computer organization and architecture is about the components of the computer system, how they interconnect and how they function. You should therefore be able to identify the main component of the computer systems and the how these components are interconnected. The basic block of a functional computer components are logic circuits. The course has made you to acquire knowledge on how to construct different logic circuits given any inputs and corresponding expected outputs.

The data representation in a computer is in terms of binary systems and it is expected that you can now evaluate different data representation. You have learnt different addressing modes which the computer uses to process the data. The module is a prerequisite to advanced computer organization and architecture.

Course Assessment

PART A- System Architecture and Design

- a. Name three major functional units of a computer.
- b. Briefly explain the main functions of each of these components.

c. Which unit are the following devices associated with

i. Keyboard

ii. Mouse

iii. Screen

. Joystick

. Webcam

vi. Speaker

d. Which is the most widely used input device when entering text?

e. Name the part of the computer where all other components connect to.

f. What is the main use of the computer's main memory?

g. The computer's main memory is of two types. List and explain how these types are used by the computer.

PART B- Data representation and logic

a. What do you understand by a number system?

b. Briefly describe the characteristics of the following number systems

i. Decimal

ii. Hexadecimal

iii. Binary

(@1 mk = 3 marks)

c. Convert the following numbers into the number system given in the question. Show how you have arrived at the answer.

i. 111022 to base 10
(4 marks)

ii. 2110 to binary (4 marks)

d. What do you understand by a logic gate? (2 marks)

e. What is a truth table when used in electronics? (2 marks)

f. Describe the basic operations of the following logic gates. Include corresponding truth tables for each logic gate. The diagram representing each gate must be given. Presuppose that there are two inputs variables, A and B and one output C for each.

i. AND (2 marks)

ii. OR (2 marks)

iii. NOT (2 marks)

. NAND (2 marks)

. NOR (2 marks)

PART C- Computer Organization [11 marks]

a) What do you understand by the following terms. Include a diagram to illustrate this.

i) Control bus

ii) Address bus

iii) Data bus (3 marks)

b) Differentiate between the following terms

i) Memory address register

ii) Memory data register (4 marks)

c) Name three important steps that are followed by a computer in executing an instruction. (1 mk each = 3 marks)

d) What is the name of the register that stores the address of the next instruction to be fetched from memory? (2 marks,)

e) What is the name of the register that is used to store an instruction that is awaiting decoding or execution? (2 marks,)

PART D- Instruction Set Architecture [10 marks]

a) What does ISA stand for? (1 mark)

b) What do you understand by

i) a memory address? (1 mark)

ii) Addressing mode? (1 marks)

c) Explain the mode of operation of each the following addressing modes. Use of a diagram to support your explanation.

i) Direct (absolute) addressing

ii) Indirect addressing

iii) Relative addressing

iv) Immediate addressing

(@1 mark= 4 marks)

d) Explain what you understand by the following instructions

MOV A, R2

(1 marks)

ii) MOV A, @R0

(1 marks)

iii) MOV @R1,A

(1 marks)

EXAM

SAMPLE ANSWERS

PART A- System Architecture and Design

a. Name three major functional units of a computer.

I expect the following as the units:-

- Input
- Output
- Central processing unit

b. Briefly explain the main functions of each of these components.

Full marks for correct functional descriptions, 0 otherwise

c. Which unit are the following devices associated with

i. Keyboard--Input unit

ii. Mouse- input unit

iii. Screen- output unit

. Joystiicvk- input unit

. Webcvam-

vi. Speaker- output unit

- d. Which is the most widely used input device when entering text? It is the keyboard
- e. Name the part of the computer where all other components connect to. This is the motherboard

PART B- Data representation and logic

a. What do you understand by a number system?- A Number system is a set of values used to represent different quantities.

b. Briefly describe the characteristics of the following number systems

i. Decimal- This consists of ten digits from 0 to 9. These digits can be used to represent any numeric value. The base of decimal number system is 10 as it uses ten digits.

ii. Hexadecimal-- is consist of 16 digits from 0 to 9 and A to F. The alphabets A to F represent decimal numbers from 10 to 15. The base of this number system is 16.

iii. Binary- 'Binary' means there are only 2 possible values: 0 and 1. One binary digit (0 or 1) is referred to as a bit, which is short for binary digit.

c. Convert the following numbers into the number system given in the question. Show how you have arrived at the answer.

i. 111022 to base 10 - $((1 * 24) + (1 * 23) + (1 * 22) + (0 * 21) + (1 * 20))10 = (16 + 8 + 4 + 0 + 1) = 2910$ (4 marks for correct methodology, 0 otherwise)

ii. 2110 to binary= 1011012 I expect the answer to include successive division by 2 and recording the remainder until correct answer is found.(3 marks for correct method, 0 otherwise)

d. What do you understand by a logic gate? This is an elementary building block of a digital circuit.

e. What is a truth table when used in electronics? It is a diagram of the outputs from all possible combinations of all inputs.

f. Describe the basic operations of the following logic gates. Include corresponding truth tables for each logic gate. The diagram representing each gate must be given. Presuppose that there are two inputs variables, A and B and one output C for each.

The following will be expected for each as the answer; logic circuit diagram (1 mark) + (.5 marks) truth table and brief description (.5marks)

i. AND

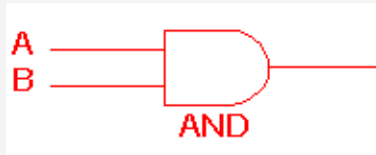

This gate got its name because of the logical “AND” operator that requires that the values of the participating variables be either both true or both false. The output will be if both inputs are TRUE else it will be “false”.

The associated truth table would be like

INPUT		OUTPUT
A	B	$AB = C$
0	0	0
0	1	0
1	0	0
1	1	1

ii. OR

The diagram would be like

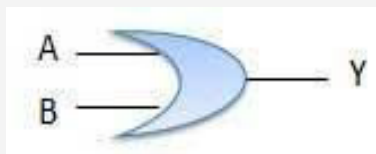

where $Y=C$

The output will be 1 (TRUE) if either or both the inputs are “TRUE”. If both inputs are “false,” then the output is “false.” The corresponding truth table would be like

Inputs outputs

Inputs		outputs
A	B	$A+B=C$
0	0	0
0	1	1
1	0	1
1	1	1

iii. NOT

This is a circuit that produces an inverted version of its input. Its logic diagram is like. This is for a single input A and output Y example

The truth table would be like

INPUT	OUTPUT
A	Y (NOT A)
0	1
1	0

iv. NAND

This kind of gate works like the AND gate only that the AND gate must be followed by a NOT gate. The diagram would be like

The truth table would be

Inputs Output

Inputs		Output
A	B	NOT(A and B)
0	0	1
0	1	1
1	0	1
1	1	0

v. NOR

The NOR gate is a combination OR gate followed by an inverter.

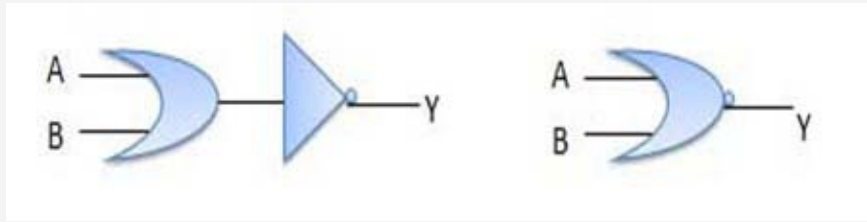

Inputs		Output
A	B	$\overline{A+B}$
0	0	1
0	1	0
1	0	0
1	1	0

PART C- Computer Organization

a. What do you understand by the following terms- I expect the following,; {full marks, 0 otherwise}

- i) Control bus- A control bus is a computer bus that is used by the CPU to communicate with devices that are contained within the computer. This occurs through physical connections such as cables or printed circuits.
- ii) Address bus- An address bus is a computer bus architecture used to transfer data between devices that are identified by the hardware address of the physical memory (the physical address), which is stored in the form of binary numbers to enable the data bus to access memory storage.
- iii) Data bus- A data bus is a system within a computer or device, consisting of a connector or set of wires, that provides transportation for data

b) Differentiate between the following terms

- i) Memory address register- is a CPU register that either stores the memory address from which data will be fetched to the CPU or the address to which data will be sent and stored
- ii) Memory data register- is the register of a computer's control unit that contains the data to be stored in the computer storage (e.g. RAM), or the data after a fetch from the computer

c) Name three important steps that are followed by a computer in executing an instruction.
I expect the mention of fetch, decode and execute

d) What is the name of the register that stores the address of the next instruction to be fetched from memory? It is program counter/ PC

e) What is the name of the register that is used to store an instruction that is awaiting decoding or execution? It is instruction register/ IR

PART D- Instruction Set Architecture

a) What does ISA stand for?- It short for Instruction Set Architecture

b) What do you understand by the following terms?

i) a memory address?- It is a unique identifier (address) often assigned at boot time that is used by the CPU to track data in the system.

ii) Addressing mode?- this is a way of specifying the location (address) of an operand in an instruction.

~~to differentiate~~ Differentiate between the following addressing modes

i) Direct (absolute) addressing

ii) Indirect addressing

iii) Relative addressing

iv) Immediate addressing

d) Explain what you understand by the following instructions

i) MOV A, R2, It means copy R2 into A

ii) MOV A, @R0- It means move the contents of RAM location whose address is held by R0 into A.

iii) MOV @R1,A - This means move the contents of A into RAM location whose address held by R1.

Course Reference

1. <http://www.karbosguide.com/books/pcarchitecture/start.htm>- PC Architecture a book by Michael Karbo- chapter 2 to chapter 8.

2. http://simple.wikipedia.org/wiki/Computer_architecture - computer architecture

3. http://en.wikiversity.org/wiki/Computer_architecture_and_organization - Computer architecture and organization.

4. http://www.tutorialspoint.com/computer_fundamentals/index.htm- Computer Fundamentals- (Read from computer types to computer hardware)

5. http://en.wikipedia.org/wiki/Computer_architecture#Instruction_set_architecture- computer architecture.
6. <http://www.cs.umd.edu/class/sum2003/cm311/Notes/Mips/format.html> Instruction format
7. http://en.wikipedia.org/wiki/MIPS_instruction_set MIPS instruction set
8. http://en.wikipedia.org/wiki/Computer_architecture computer architecture
9. http://simple.wikipedia.org/wiki/Computer_architecture - computer architecture
10. http://en.wikiversity.org/wiki/Computer_architecture_and_organization - Computer architecture and organization. http://en.wikipedia.org/wiki/Computer_architecture.
11. <http://www.karbosguide.com/books/pcarchitecture/start.htm> PC Architecture a book by Michael Karbo. chapter 29.
12. <http://en.wikipedia.org/wiki/Multiprocessing> multiprocessing.
13. http://homepage.cs.uri.edu/book/cpu_memory/http://cs.sru.edu/~mullins/cpsc100book/IntroToCS.htmlcpu_memory.htm How Computers Work: The CPU and Memory.
14. http://www.tutorialspoint.com/computer_fundamentals/index.htm- Computer Fundamentals
15. http://en.wikipedia.org/wiki/Computer_architecture#Instruction_set_architecture computer architecture.
16. <http://www.cs.toronto.edu/~demke/469F.06/Lectures/Lecture6.pdf>- Lecture on Interrupts (University of Toronto)
17. <http://people.freebsd.org/~jhb/papers/bsdcan/2007/article/article.html> PCI Interrupts for x86 Machines under FreeBSD
18. http://en.wikipedia.org/wiki/Instruction_set Instruction set

Unit 5: Impact and History of Computers

5

INTRODUCTION

Technology influences different areas of society and business, whether it is a particular age group or gender, or the entire population. We may be resistant to its influences, whether in the long or short term, until we are more aware on how this change impacts our lives, families, work, entertainment, or daily living.

This unit explains terms associated with computer technology, explains its influence, and contributions to various aspects of work and play. Then it briefly reviews the development of the technology and explains the different categories of computer systems.

UNIT OBJECTIVES

At the end of this unit, you should be able to:

1. Define terms and explain characteristics associated with computer technology.
2. Discuss the influence of computer technology in a society.
3. Discuss the contributions of computer technology to education.
4. Discuss the contributions of computer technology to business.
5. Discuss the contributions of computer technology to everyday living.

This unit is divided into three topics:

Topic 1: Computer Technology – An Introduction Topic 2: Information Technology – The Concepts Topic 3: Computer Technology in Work and Play

TOPIC 1 – COMPUTER TECHNOLOGY – AN INTRODUCTION

INTRODUCTION

6. Computer Technology is now part of our everyday life, and almost every task we encounter involves the use of computer technology. This Topic will first help you to understand computer technology and its impact in society.

OBJECTIVES

After studying this topic, you will be able to:

1. Explain terms associated with computer technology.
2. Explain features of computer technology.
3. Explain features of computer technology.
4. Discuss the extent to which computer technology has increased access and flexibility.
5. Discuss the extent to which computer technology has changed the communication landscape.

INTRODUCTION TO COMPUTER TECHNOLOGY

Let us start by understanding the concept of computer technology. Quickly, in 30 seconds, calculate the answer to $12 + 54 + 23.65 + 12.89 + 23\frac{1}{4} + 90 + 12 + 980 + 234 + 567$ in your head or on paper. Did you complete it in time? See the next page for the answer.

You may be surprised to learn that people were the first computers! The term computer means someone who computes or performs calculations. Centuries ago, people were called computers. They were usually women who worked out mathematical problems such as tidal charts or navigational tables, and so 'Computer' was actually a job title.

However, as you can imagine, performing mathematical tasks every day, every week, every month would eventually cause boredom which would cause errors in the calculations.

Therefore, the computer became a machine which automated these repetitive tasks. A computer

therefore is a machine which:

- accepts data (called **INPUT**);
- follows instructions given on what to do with the data (called **PROCESSING**);
- stores the results for future use (called **STORAGE**); and
- Display the results (called **OUTPUT**).

Answer: 2008.79

By applying technology to different problems and work environments we can enhance situations or events that would have been almost inconceivable without it. For example, voice mail, satellite television or cell phones are all examples of technology that use a computer to operate the system. Computer technology therefore involves any machine, tool or piece of equipment that is essentially controlled by a computer chip that is able to make calculations.

The role of computers and computer technology is the ability to manipulate data into information or commands. Data can be in many forms, such as text, pictures or sound and can also be retrieved

from the environment. An air conditioner which monitors the temperature in a room to keep it cool at a specific temperature, or turning on lights outside a building at dusk are both examples of a computer controlled environment that requires input to produce a specific result or output.

	Air Conditioner	Automated Lights
Input	Current Temperature Desired Temperature	Dusk
Output	AC adjusts temperature to desired temperature	Lights On

Activity 1.1 Consider why it is essential that data and information must have the following qualities:

- Relevant
- Complete
- Accurate
- Clear
- Reliable
- Concise
- Timely

Turn to Appendix One for Suggested Response

COMPUTER TECHNOLOGY IS EVERYWHERE

Information has become very important as a result of the computer technology which provides it. Computer driven technology is an integral part of our daily routines, however we tend not to be aware of its presence. Many of our daily tasks are automated; such as our answering machines, televisions, cable boxes, vehicles that use this technology. Similarly, as a cashier prints out our receipt for a purchased item or the mail we receive that was stamped by a machine, computer technology supported the creation of the receipt or the delivery of our mail automatically.

We therefore say that computer technology is *ubiquitous*, or everywhere (almost!) once information is present. To summarize, many utility companies are now recording our usage to prepare monthly bills, which will be printed by a machine, while a local or overseas phone companies record voice messages and the calls we missed. Also, our banks' automated systems are automatically charging us every time we use the debit or credit card. The automated systems are controlled by a computer process based on the input from your retailer, the machine itself or from the scanner.

Activity 1.2 - Describe how computer technology is integrated in the following sectors:

- Agriculture
- Education
- Theatre or the Arts

Turn to Appendix One for Suggested Response

GENERATING INFORMATION

Remember that computers store the results or output of processing the data. Well computer technology has enabled us to access information at our "finger tips"; from many places, in many places, at any time, and in many different forms whether printed or stored. Hence as more information is requested, more information is generated and more data stored. It seems like a never ending cycle of information growing exponentially!

Activity 1.3 – Think of some specific examples, that you could use to explain what is meant by the phrase:

“... Computer technology has enabled us to access information ... from many places, in many places, at any time...”

Turn to Appendix One for Suggested Response

Unfortunately, there is a drawback to generating information on every transaction. Imagine how one minor error can mushroom into major problems because of your computer technology, and this can have a negative impact on businesses and customers alike. In addition, most people who are not in the computer field may believe that whatever the computer produces is correct. Consider the consequences of transposing (switching) two digits in a bank account number or entering the wrong data in payroll system. This can cause embarrassment to the persons involved if deposits are made to the wrong account or employees do not receive the correct pay. Even so, it is also more difficult to locate someone who is willing to accept responsibility for an error made by a computerized system. This lack of accountability for the error would be better addressed if the software glitch was corrected as soon as possible!

We should also realize that since information is constantly generated, then it should be possible to store it over a long period of time. It is reasonable to assume therefore that information cannot be entirely destroyed or lost.

Activity 1.4 - Describe two procedures or methods that should be implemented to ensure that information is not lost or destroyed.

Turn to Appendix One for Suggested Response

ACCESSING INFORMATION

Much of the computer information that is generated and held in a database is available on- line. For

example, customers can use the telephone or Internet to access current bank balances and perform transactions. Access to your banking information can be made from almost anywhere in the world. This has led to a new work ethic where computer technology has enabled employees to work from various geographic locations, or time zones. Computer technology has provided people with increased mobility while talking with someone on the phone, or receiving a fax.

Information can be retrieved and sent in many forms including text, voice, graphics, photos and video. Additionally, the "information superhighway" has increased the availability of these forms of information delivery methods. One major concern of the recording industry is the ability to reproduce digital material such as video tapes and DVDs, which are indistinguishable from the original. This technology has caused headaches to the industry's composers and performers since any digital file can be easily duplicated and shared.

Activity 1.5 - How would you explain the term "information superhighway" to a family member? When considering your explanation highlight some characteristics that are implied in the term.

Turn to Appendix One for Suggested Response

With access to information, and digital voice and smart technologies automated voices have replaced operators who traditionally greeted customers and initially responded to their queries. It is now commonplace to call businesses and hear an automated switching system and voice mail system instead of an actual person who can assist you.

Activity 1.6 - Think of three companies in your country that have automated responses to transfer you to an extension or department. Consider how hearing an automated response or a human voice personally affects you, and what these effects are.

Turn to Appendix One for Suggested Response

SURVEILLANCE

Computer technology has certainly allowed surveillance or the gathering of information for different purposes. Surveillance software allows individuals, companies and government to monitor you in a variety of locations including other countries. Surveillance equipment such as cameras and key pads now include transactional data which is collected from virtually all types of transactions, including cash purchases and the acquisition of services to analyze trends. One example is the use of Google Earth to capture topographical pictures of different locations on the earth and more recently Google has released their street view software that allows you to wander the streets of your city using 3D technologies. Take a look at it by clicking here.

Activity 1.7 - After viewing Google Street View, consider why investigators would want to use surveillance to analyze pedestrian traffic in a town, or weather patterns in a particular area of the country.

Turn to Appendix One for Suggested Response

CHANGING THE WAY WE COMMUNICATE

With the use of the computer and its technology used extensively throughout our society, you are probably aware of how computer technology has changed the way we communicate with another person or among groups of people. The use of email, instant messenger and text messages have modified the usual visual and verbal signs when communicating with someone else. This of course can be both a benefit and a detriment to the communication process. For example, the use of computer tools such as email, instant messenger and text messages mask features such as gender, race, age, and physical disability, social or marital status.

Even distance learning has changed the way people are educated, as this manual and your online activities illustrate! Your relationship with the facilitator is remote and you may only hear a voice or read the words on a page written by your instructor. Much of the distance or blended learning materials and content are delivered through the use of databases, audio or video feeds and other means such as Moodle or Blackboard. This has become a reality for many who wish to further their education while employed full-time or those who are unable to access a physical campus at a local institution.

Activity 1.8 - Identify:

Different symbols that are used to represent emotions in email messages, instant messenger and text messages.

Think of different words or phrases that have been shortened or modified in email messages, instant messenger and text messages

Turn to Appendix One for Suggested Response

TOPIC SUMMARY

During the review of this topic we learned that computers impact every aspect of our life. As a future entrepreneur you must learn to recognize the potential of computer technologies and how to incorporate them into your business environment and business plan. Consider the type of information you need access to, the type of information your customers need and how to communicate this information to your target audience. The next topic discussion on "Information Technologies" will help you better understand the concepts related to computer and information technologies and provide another perspective on how IT impacts our lives.

TOPIC 1.2 – INFORMATION TECHNOLOGY (IT) – THE CONCEPTS

INTRODUCTION

As noted in Topic 1.1 computers play a major role in our daily lives. Business demands the use of computers to support business operations. As an entrepreneur it is important that you understand and use computer technologies effectively to help grow your business.

Before exploring the details of a business computer environment, you need to understand what we mean by information technology and how it influences society.

OBJECTIVES

Upon completion of this lesson you will be able to:

1. Define information technology.
2. Explore the main uses of computers in society.
3. Describe the impact of computers on society, education, industry, government and business.

WHAT IS INFORMATION TECHNOLOGY?

Let's first look at some key terms before we define the concept information technology.

Let's start with the term *information*. Information refers to data that has been put into a meaningful and useful context.

Information systems refer to a set of people, procedures and resources that collects, transforms, and disseminates information in an organization. Information systems are implemented within an organization for the purpose of improving the effectiveness and efficiency of that organization.

As an entrepreneur you will need to use a system to provide for the flow of information within your business. Computers is playing a vital part in obtaining, processing and sharing information within a business which means that an entrepreneur will have to make use of a computer-based information system.

This requires that you must have an understanding technologies used in computer-based information systems – use of hardware, software and people resources to transform data resources into information.

Back to our question: What is meant by Information Technology?

Information Technology (IT) is the area of managing technology and spans a wide variety of areas that include but are not limited to things such as processes, computer software, information systems, computer hardware, programming languages, and data constructs. In short, anything that renders data, information or perceived knowledge in any visual format whatsoever, via any multimedia distribution mechanism, is considered part of the domain space known as Information Technology (IT) (Wikipedia).

TechAmerica defines IT as the study, design and implementation of computer based information systems, particularly software applications and computer hardware. IT deals with the use of electronic computers and computer software to convert, store, protect, process, transmit and securely retrieve information (www.answer.com).

The discipline of Information Systems can best be described as the effective analysis, design, construction, delivery, management and use of information and information technology in organizations and society. An Information System, per se, is an organized collection of people, procedures, data, machines and services that work together to deliver information (<http://www.is.ru.ac.za/?q=content-2>).

So we can conclude that:

Information technology (IT) refers to the different ways (electronic computers and computer software) of obtaining, processing, storing, and transmitting data in the form of voice, pictures and words.

The term Information Technology (IT) is also known as Information Communication Technology (ICT), and we shall continue to use that term henceforth because it combines computing and communications. The computer is a key feature of ICT and the key to an effective business is how the entrepreneur uses his or her ICT resources to grow and manage the business.

It is clear from our brief discussion that computer technology plays a vital role in everyday life. Now take

a few minutes to complete the following activity.

Activity 1.9 - *You have no doubt have come across a computer of some kind in your everyday tasks, be it directly or indirectly. Do you agree?*

In Column A, list five places where computers can be used in operating a business or in your local community and in Column B suggest how the entrepreneur can use these computers to support ICT.

Turn to Appendix One for Suggested Response

PLACE	USE

You might have referred to places such as schools, businesses, government institutions and the individual at home. Work through the following information and compare it with your answers for this activity.

IMPACT OF INFORMATION AND COMMUNICATION TECHNOLOGY (ICT) ON SOCIETY

Today’s society is referred to as the ‘digital age’. Computers and ICT devices have become an integral part of our lives and are used everywhere. Be it the desktop computers, laptop computers or more recently tablet computers, all contribute to the activities we experience in our daily life. We use these devices in schools, at home, hospitals, institutions, businesses and even in government offices.

In general the impact of computers on society and how we live our lives is as follows:

- You can use computers to communicate with your family and friends, create a household budget, book travel and movie tickets, or manage your business. The internet has also tremendously increased people’s ability to communicate with others from all over the world efficiently and relatively cheaply.
- In business and industry, you use computers to maintain accounts, create personnel records, track inventory, prepare presentations and reports, manage projects, and
- Communicate by email. You can use computers to design any type of publication ranging

from simple news letters to fashion magazines, marketing materials, books, or newspapers.

- In the field of education, trainers can use computers to deliver training through audio-visual learning aids, maintain student records to track performance, search for information on different topics, and create or submit assignments.
- In government organizations, you use computers to organize information by storing and updating records. Computers are also used for providing services to citizens. For example, you can view information on current policies and government issues on a computer.
- In the field of medicine, doctors use computers to review medical records of patients. Doctors also use computers to find information about the latest drugs available to treat a disease. Doctors can also use computer technology to discuss and share information about various diseases.
- You can use computers to view the details of your bank account. Traders use computer technology to get instant information on stock markets, to trade stocks, and to manage investments.
- Scientists use computers for scientific research, and to gather and analyze information. For example, they use computers to view images from space and to publish information on their recent research.
- You can also use computers to create drawings and paintings. Photographers use computers to edit and enhance pictures. Writers use computers to write content for their books and to also create illustrations. By using computers, writers can make changes in the content easily and save a lot of time.
- In the field of entertainment, you can use computers to listen to music, watch movies, store and print photographs, send greetings, and play games.

[Source: Microsoft Corporation]

THREATS TO INFORMATION SYSTEMS

Computer based information systems are much more vulnerable to crime and abuse, natural disaster, and even human error than manual systems that they have replaced.

A Computer Crime

Computer crime ranges from the use of information technology to commit an act that would be criminal no matter how committed (such as the theft of money or other property) to activities more specifically related to computers, such as the unauthorized

Introduction to Computers

access and use of information systems, theft of computer and telecommunications services, and the theft, intentional alteration, or destruction of data or programs. The protection of customer data and business confidential information is an issue that faces all entrepreneurs.

B Theft of Money

As financial institutions become more and more reliant on computers, new opportunities have

arisen for criminals to use computers to steal or siphon off money. Password protection and other security tools must be used to protect bank accounts, investments and other financial resources.

C Theft of Computers and Computer Parts

As computers and the various computer parts have become smaller and smaller, it has become easier to steal. Microprocessor chips, memory chips, motherboards, modems, disk drives, and power supplies are all frequent targets. They can be removed relatively easily and sold to a readily available underground market. Physical security and effective inventory control measures should be implemented.

D Alteration or Destruction of Data and Programs

Another form of computer crime involves the alteration or destruction of data and programs. Motives for this crime may include monetary gain, revenge or just being malicious. This ties in with **computer viruses**, which are a set of illicit instructions implanted within a program that passes itself onto other programs with which it comes into contact. Appropriate software must be used to protect your business files, data and other online resources from external and internal attacks by cyber criminals and hackers.

E System Disasters

In addition to computer crime, information systems are susceptible to natural disasters (Rain, earthquakes, fire and floods), terrorist attack, electrical power and telecommunications line failure, hardware and software malfunction, even human error. Off-site backups and in some cases backups to computers in another island or nation is recommended when your region is subjected to regular natural disasters.

Now do the following activity to test your understanding of the positive and negative impact of computers and ICT on society.

Activity 1.10 - Read the following case and reflect on the information before you look at the questions that follow. In 1999, heavy rains collapsed the roof of a computer centre in

Pretoria, knocking out computers that handled transactions for over 4000 ATMs nationwide. As a result, over 1 million cardholders were temporarily deprived of their access to their funds through other teller networks, but because those networks lacked data about account balances, cash withdrawals were limited to R100 a day to reduce fraud.

Hint: Think of examples of how technology impact (both positively and negatively) your life personally and how it will impact the entrepreneur in his business.

Turn to Appendix One for Suggested Response

It is advised that you share your ideas/answers with fellow students by engaging in face-to-face discussion, via e-mail or use social media such as Facebook and Skype.

This brings us to the end of topic 1. Hope you did well in doing the activities. Let's summarise what we have discussed.

TOPIC SUMMARY

In this topic we have learned that:

- Information technology refers to the different ways (electronic computers and computer software) of obtaining, processing, storing, and transmitting data in the form of voice, pictures and words.
- Computer technologies directly and indirectly impact society, business and industry, education

and government.

- Individuals and different organizations use computer technology for communication, to provide services to citizens, to record transactions, do banking, listen to music, and do drawings and paintings, to do research and many more functions.
- IT also poses threats to society. Threats include computer crime, theft, system disasters and alteration/destruction of data and programs.

Now as we are through with defining information technology let's move on to the next topic where we will discuss the basics of computer in detail.

TOPIC 3 - COMPUTER TECHNOLOGY IN WORK AND PLAY

INTRODUCTION

Now that we have understood some terminology and features of computer technology, let us look more closely at various aspects of work and play, and how technology affects each one.

This section will allow discussion on some of the impacts in the last, and thoughts on the next decade.

Inventions already introduced into society through computer technology, have caused the society to change, with the cellular phone (or cell phone) being the most recent to reach the populations. It is now an everyday occurrence to reach anyone, anywhere with the use of a cellular phone. Not as openly known, but still commonplace however, is the use of the smart prosthesis on someone who previously could not walk after an accident. Simulations of people walking or running for example have furthered the invention of essential types of prostheses.

OBJECTIVES

After studying this topic, you will be able to:

1. Identify the advantages and disadvantages of computer technology in various aspects of society.
2. Discuss the man-machine connection.

SCIENCE, MEDICINE, HEALTH AND TECHNOLOGY

Simulation and simulators are often used in scientific research to mimic the event that is being studied. These programs quickly perform number crunching calculations, so that the event can be accelerated, slowed or changed to help predict and test certain outcomes.

Therefore programs can assist with the simulation of training in dangerous situations, without using expensive resources.

Activity 1.11 - Consider the benefits of simulations in each of the following:

- Space travel
- Weather
- Disaster prevention and recovery
- Loss of limbs

Turn to Appendix One for Suggested Response

Since health care matters to everyone, it is not surprising that computer technology has become a natural part of our health and wellbeing, but its use and relevance has implications in everything we do...and not do! If you would like to explore how medical organizations are using simulation and other computer technologies to provide professional development to health care professionals and support science education in the schools go to the [Howard Hughes Medical Institute, Bio-interactive site.](#)

Computer technology is integral part of the health and wellness sector. CTI scanners and other diagnostic tools are driven by computer technology. Our health records are placed into databases to be used and retrieved when you visit the hospital or your local doctor.

Science has had an incredible impact within the last century. Toffler in his book "The Third Wave" has identified computer technology as a new phase in the evolution of society.

Technology has made the following medical procedures possible. Many of these procedures have generated considerable debate about the ethics of these procedures. Some of these procedures include the use of technology to support:

- test tube babies;
- organ transplants;
- cloning;
- nuclear radiation;
- limb replacement;
- gene therapy; and
- nerve regeneration.

Telemedicine

Some of you may have previously seen or heard the terms teleconferencing or telecommuting. The Greek word 'tele' means 'distance', so teleconferencing provides opportunities to have a conference without all persons having to be in the same room, city or country. Similarly telecommuting or the less popular term, 'tele-working', was first offered in the 1960s by the information technology industry. This arrangement allowed employees to work at home and communicate with the office by methods such as phone, fax and computer.

So we now have yet another term 'telemedicine', where 'medicine'. Telemedicine involves telecommunications, where medical personnel and their patients are separated by some physical distance but are connected through technology so the professional can complete a medical procedure. Some of the services offered by telemedicine include medical

diagnoses, pathology, radiology, and consultation, so that expertise can be made available in rural and remote areas.

Medical Self-Diagnoses

Many people are using knowledge based database systems to research cures and

symptoms of ailments, probably for self-diagnoses. These database systems, called expert systems perform tasks that would otherwise be performed by someone with expertise in the field. Expert systems can be used, not only to diagnose human illnesses, but also to make financial forecasts, and schedule routes for delivery vehicles. However it is important to note that while some expert systems replace human experts, there are others designed to assist them.

Having a medical complaint which is embarrassing should not be the sole reason to avoid consulting a doctor. Although there are well-documented and researched medical expert systems (such as WebMD) being able to access a website on the Internet to diagnose symptoms does not automatically validate the authenticity or correctness of the online diagnosis. Only a doctor can do this.

Activity 1.12 - Why would you and others want to perform self-diagnosis using an Internet medical search engine? Think about the precautions that you must consider when using such search engines.

Turn to Appendix One for Suggested Response

Database technologies are now used to store dental records, x-rays, medical insurance forms and other records for administrative, management and cross referencing. Here are some further examples of the development of database systems with associated technologies which are used as expert systems and have become tools for medical research.

Research

Research on genetics has discovered entire sets of genetic instructions in the cells of our body, their sequences and any possible unique features or abnormalities. Using computer technology has afforded:

The discovery of a gene which has the pre-disposition to develop colon cancer can save a life if genetic screening is done early. In contrast, persons in the early 1970s were either denied insurance coverage or were asked to pay increased premiums if they carried the gene for sickle cell anemia.

Forensic personnel used computer technology to assist in the identification of people missing at the World Trade Centre. Tools were used to compare the victims' DNA with an item used by the victims, such as a toothbrush.

Activity 1.13 - Consider the moral and ethical implications for using computer technology to search databases for screening employees DNA; for other diseases such as HIV/AIDS; or for conducting criminal background checks.

Turn to Appendix One for Suggested Response

EDUCATION AND TECHNOLOGY

Computer technology has moved the classroom from a teacher using a 'chalk and blackboard' to deliver passive instruction to student centred, discovery learning environments

that employ a variety of computer and Internet technologies. Computer technology has allowed disenfranchised students in places like rural areas who at one time could not participate in traditional instruction to benefit from an anywhere, anyplace philosophy for the delivery of educational programs.

In Barbados, technology is now becoming a part of the classroom with the assistance of a government sponsored educational initiative called Edutech 2000. This programme is providing training in Information and Computer Technologies (ICTs) for teachers and students alike in order to develop the country's future workforce and ensure the country has suitable skills to compete in the international market.

In most countries today the typical public school program includes some instruction in computer technology, computer literacy skills and software familiarization. Most public schools throughout the Caribbean and parts of Africa have access to computers within their schools. Technology is being used to support instruction and increase student and teacher technical knowledge and skills.

The introduction of computers to support classroom instruction has met mixed reactions. Some teachers embrace it, but many resist it because they don't have the pre-requisite skills to properly employ the technologies. Change will take time, resources and more teacher professional development. The Commonwealth of Learning is supporting the Open School Movement and the use of ICT to support instruction and student learning. Check it out.

Computer technologies and the advent of the Internet have allowed online universities to flourish. Examples of fully online universities include Indira Gandhi National Open University, National Open University of Nigeria, Athabasca University and the Open University of the United Kingdom. Online universities and similar organizations around the world provide opportunities for millions of students to study anywhere and at any time.

Working professionals are now able to further their education without having to travel while maintaining full-time employment and an appropriate quality of life.

There are some disadvantages however with online activities, which include the lack of opportunity for human interaction and socialization. Many online students experience the feeling of isolation. Although the inclusion of online discussion forums and chat capabilities have somewhat alleviated this problem, there is still an issue with misinterpretation and miscommunication associated with text messages and phrases.

The online learning environment is slowly embracing new technologies like Podcasts, social networking software like Facebook, instant messaging technologies like Skype and web conferencing systems like Elluminate. Web 2.0 tools are helping close the social divide and providing more opportunities to interact with peers, learners and others in the educational communities.

Activity 1.14 – Based on your own experiences with distance education, think about the potential impact that an online university has on its students.

Turn to Appendix One for Suggested Response

BUSINESS AND TECHNOLOGY

Computer technology has had a major impact on day-to-day business operations. Today companies that have failed to incorporate technology are viewed as being 'not-up-to-date' or archaic. Today organizations must have a presence on the Internet. Their company's goods and services must be marketed online. Prolific use of electronic mail (or email) and electronic forms have replaced paper

based forms and traditional snail mail (letters mailed through a post office). It is now the norm for business professionals to use technology to produce every memo, envelope, label and document using a word processor. Effective marketing materials require the use of graphic software and more to create and produce the layouts. Business presentations are created using computer software and delivered via laptop computers and projectors. Electronic payments and business banking accounts require the use of e-commerce software and secure Internet connections. The computer revolution has allowed traditional businesses to reduce infrastructure costs by allowing their employees to work from home. In North America over 40 million employees work from home using different types of Information and Communications Technologies (ICTs).

As traditional business practices become automated business leaders and HR personnel now demand that their current and future employees be computer literate. In the many parts of the developing world it is proving to be a challenge for those who are unable to reach the required standard thus impacting their employability.

Activity 1.13—Consider the following and if you have opportunity discuss it with others.

What statement best reflects your belief about computer technology and the automation of tasks in the workplace.

1. ICT increases productivity in the workplace.
2. ICT hinders productivity in the workplace.
3. ICT has had no impact on workplace productivity.

SOCIAL INTERACTIONS AND RELATIONSHIPS

The ability to text chat in a real time environment with your peers is known as Internet Relay Chat (IRC). IRC tools to support chat are available through your cell phone provider or on the Internet. Some of the more popular real time chat tools include Microsoft Live Messenger, Yahoo Messenger and others. These tools are becoming the norm for social interaction (especially among younger computer users) and it challenges in how people have traditionally interacted with each other—face to face discussions vice text chats with its own sub-culture language.

As the cartoon below illustrates texting has become part of our culture.



I suspect there were smiles as you read the cartoon, but has the cartoon become a reality today? Are people unknowingly hiding behind the technology in order to minimize communicating with each other? Do people speak more freely with the use of technology or in person?

Over the years the Internet has evolved from a deliverer of static information text based technology to a platform that encourages social networking, idea exchange, collaboration and online community building. Tools like Facebook, Yahoo Groups and others allow

individuals to connect with individuals of like minds and create their own virtual network of friends and colleagues. Tools like YouTube and Blogger have allowed everyone to create and share their own information. Everyone has opportunity to contribute to the world knowledge base and provide their own interpretation of personal, local, regional or national events.

This form of the Internet is known as Web 2.0 and has democratized our virtual space. Everyone is now equal and can post personal messages for the world to read.

Activity 1.16—Search the Internet and see if you can discover other social networking sites that you would like to participate in or share with your peers. If you have a course web site or email list feel free to share you link with others and describe why you think your site reflects the values of community building, social collaboration and knowledge sharing.

MAN-MACHINE CONNECTION

I would hope by now that you would agree much of the world cannot live without having some form of computer technology in their lives. Does this mean that we are controlling computer technology or is the technology controlling us? During the late 1980s and 1990s, the Internet invaded our lives. Movies and TV shows included the Internet and sophisticated computers to entertain us. Some interesting ones were the 1982-1986 weekly television crime fighter series 'Knight Rider' which portrayed a modern-day hero who drove a high-tech smart car equipped with artificial intelligence. Sandra Bullock's 1995 movie 'The Net', involved an Alfred Hitchcock style drama about having her identity electronically erased and replaced with a stranger's information. Then in 1998, there is Will Smith starring in 'Enemy of the State' which speaks about the use of satellites to track people, as well as in 'I Robot' in 2004 about a 'humanoid' robot that is suspected to have murdered its creator. Whether you have seen these movies or not, the implicit use of computer technology in each of them sends the message that whether to help or hinder, that technology is everywhere. Today it is digitally generated 3D movies and animations like Avatar have caught our attention. These movies would not be possible without computer generated images and human machine interactions to capture life like character movement.

Technology has advanced so fast that more and more computers have an incredibly high fault tolerance, with robots automating the repair process, without any human intervention. One example are the robots that are used by NASA to repair the International Space Station. Seriously, we are not that far away from computers repairing themselves.

Let us now consider computer logics. Do "they" have the capability of handling complex thought processes like human ones? Almost!

An Example – Man Machine Practical Application

In 1998, a technology entrepreneur in northeastern Washington was implanted with a Radio

Frequency Identification (RFID) chip into his hand in order to experiment with the technology. The chip and supporting computer technology was used to gain keyless entry to his car and home, turn on lights, logon to his and other remote and repetitive applications. The experiment was successful and led to other applications for RFID technology..

An implantable RFID chip is a minuscule capsule containing a microchip and an antenna, all enclosed in glass. The chip is about the size of a grain of rice. RFID chips work by storing a unique identification number in the microchip. This number can be retrieved by a special RFID reader that is held within close proximity. Today there are most often implemented in animals to track their whereabouts and to include owner information that can be retrieved by a scanner used by a vet or other animal agency

Although RFID technology is relatively old, it is still considered a controversial technology. Privacy advocates fear that the technology might be abused by governments and used to track people. Microchip implants have been used for years for tracking lost pets. Further European research in the area was recently dealt a blow when the European Group on Ethics in Science and New Technologies made a presentation to the European Union raising privacy concerns over the potential for such chips to be used to track members of the public.

When employing different technologies we must be aware of not only the technical issues, but issues of privacy, morality, society norms and ethical practices.

TOPIC SUMMARY

This topic discussed the impact of technology on society. It demonstrated that ICT and computer technologies are an integral part of everyday life. It drives our businesses, entertains us, educates us, and helps ensure our health and wellness. As an entrepreneur you must stay abreast of technological innovations. You must consider how they can help you do your business and more importantly how you can use them to support or create new products and services.

UNIT 1 SUMMARY

After reviewing this unit, reading the suggested articles and exploring the different links you should have concluded that:

- It seems that computer technology is largely responsible for the 'emergency' attitude of modern society. The perception that everything must be done faster, arrive sooner, or be available immediately has pushed services and information to be frequently available on a 24-hour basis.
- With computer technology, the types of negative impacts and the number of people directly affected by a single system error has grown enormously to where millions can be directly affected.
- There is *unprecedented* accessibility to information and communications, available to large numbers of people from nearly anywhere we happen to be.
- A computer is a machine which accepts data (called input), follows instructions given on what to do with the data (called processing), stores the results for future use (called storage) and displays the results (called output).
- The main role of computers and computer technology is the ability to manipulate data into information
- Computer technology is *ubiquitous*, or (almost) everywhere.
- Computer technology has enabled us to access information at our 'fingertips', from many places, in many places, at any time, and in many different forms whether printed or stored.
- Information can be retrieved in many forms such as text, voice, graphics, and video
- Computer technology has allowed surveillance to be made easier with the additional software that can monitor locations in other countries.
- Computer technology has changed the way we communicate with another person or among groups of people
- Computer technology can improve our lives in health and medicine such as research in cures for diseases
- Teleconferencing provides opportunities to have a conference without all persons having to be in the same room, city or country
- Telecommuting allows employees to work at home and communicate with the office by methods such as phone, fax and computer.
- Telemedicine involves telecommunications, where medical personnel and the patient are separated by some physical distance
- Expert systems perform tasks that would otherwise be performed by someone with expertise in the field

- Databases are now used to store dental records, x-rays, medical, insurance and other records for searches and purposes of cross referencing
- Computertechnology has not completely replaced previous inventions; rather it is enhancing and improving on previous ones
- Businesses have felt most of the impact of computer technology, such that if there is little technology incorporated then the business may be frowned upon as being 'not-up- to- date' or archaic.
- Internet relay chat (also known as messenger), is a common method of chatting with someone either next to you in class, or is a local phone call away
- Many of us cannot live without having some form of computer technology in our lives

This unit introduced the general ideas associated with the impact of technology on different sectors of our society. Are you explored these impacts, you should have noted that they range from the practical and necessary to what may be regarded as leading edge or radical. However in all eras of human history, (a subtle change from 'revolution', as in the Industrial Revolution!), our different societies have been faced with change in almost every aspect of their life. This change has been accelerated by the intervention and adoption of computer technologies. It is hoped that this unit caused you to reflect upon the advantages and disadvantages of technology and how it impacts all of us.

Unit 6: Computer Hardware

INTRODUCTION

This unit discusses the evolution of computer hardware, provides an introduction to the basic components of a computer system and explains how a computer processes data that executes different computer instructions.

UNIT OBJECTIVES

At the end of this unit, you should be able to:

1. Explore the history and evolution of computer technology.
2. Explain the events that occurred in different computer generations.
3. Evaluate the various types of computer systems that have evolved since 1985.
4. Describe the basic components of a computer system.

This unit is divided into the following topics:

- | | |
|----------|--------------------------------------|
| Topic 1: | The Evolution of Computer Technology |
| Topic 2: | Computer Hardware and Peripherals |

TOPIC 1 – THE EVOLUTION OF COMPUTER TECHNOLOGY

INTRODUCTION

Today many jobs mainly depend on either the creation or collection, and distribution of information. This topic addresses the different advancements in computer technology and the various types of computers and their critical components.

OBJECTIVES

After studying this topic, you will be able to:

1. Describe the major developments in each generation of computer development.
2. Evaluate the need for different types of computer systems

COMPUTER GENERATIONS

As each new computer generation improves on its previous generation, there have been a corresponding reduction in size (or miniaturization) of computer circuitry. In contrast to this miniaturization, the speed, power, and memory of computers have proportionally increased. Although this Topic will describe the major developments of each computer generation, it is more important to consider how the technology has influenced the development of current computer systems.

The computer generations are summarized in Table 2.1 below:

Generation	Denoted by	Approximate range of years
1	Vacuum tube	1940s- 1950s
2	Transistor	Mid 1950s – early 1960s
3	Integrated circuit	Early 1960s – Early 1970s
4	Very Large Scale Integration/Microprocessor	Early 1970s – Mid 1980s
5	Parallel processing	Mid 1980s – Early 1990s
6	Reduced Instruction Set Chip (RISC) and more inventions to date	Mid 1990s to Present

THE FIRST GENERATION COMPUTER (1940s- 1950 s)

Vacuum Tubes

These early computers comprised huge vacuum tubes (similar to light bulbs) whose main purpose was to strengthen weak signals for transmission. The vacuum tubes acted as switches to start and stop the instant flow of electricity. The concept underlying the on/off switch was the idea of ones and zeros. The combination of ones and zeros or on and off created a type of machine language that could be used to process information.

The first computer, the Mark 1, was so huge that it filled a typical stadium field and was said to have used more than 500 miles of wire. Its success however was its processing power, such as a

mathematical problem that normally took 40 hours to solve, only took the Mark 1, 20 seconds to produce a result. It was used by the U.S. Navy during World War II, to help solve strategic military mathematical problems such as cracking secret codes and creating complex fire tables for naval guns and artillery. Scientists used the computer to predict weather patterns and for analyzing problems in airplane design. As noted earlier the language of this first generation was called machine language, which comprised zeros and ones for programming the computer.

The next computer, the ENIAC (Electronic Numerical Integrator and Computer) was an improvement on the Mark 1, since its processing power was about 1,000 times faster. The ENIAC was about 80 feet (24.4 m) long by 3 feet (0.9 m) wide, and used about 18,000 vacuum tubes. Unfortunately, the tubes were very hot, had to be replaced frequently, and were costly in using much electricity to keep them cool. The UNIVAC (Universal Automatic Computer) soon replaced the ENIAC by containing a compact 5000 tubes, a reduction from the 18,000 used in the ENIAC.

The Second Generation Computer (Mid 1950s – early 1960s) Transistors

During this generation the significantly smaller transistors (a new technology) eventually replaced vacuum tubes as the processing component of the computer. This allowed engineers to dramatically reduce the size and space needed to house a computer.

Transistors proved to be cheaper to produce and emitted no heat, thus reducing the costs of manufacturing and making the technology more reliable since they conducted electricity faster than vacuum tubes and failed less often.

This generation was noted for making space travel possible, and for the development of more sophisticated programming languages that allowed programmers to use short specific terms (e.g. ADD) to represent certain computer processing instructions. Higher level programming languages such as FORTRAN, ALGOL and COBOL, which use short English-like words, were developed during this generation. During this generation computer hardware

and software was created that allowed users to store and retrieve programming instructions.

The Third Generation Computer (Early 1960s – Early 1970s)

Integrated Circuits

This generation improved on the previous one by miniaturizing the transistor and building several onto a single chip of silicon. This compacting of millions of transistors in a small space, also called an integrated circuit, greatly increased the power of computer, the processing speed, lowered its production cost even more and reduced the size of the computer.

During this generation the creation of new input and output devices were created. Keyboards, monitors, and the mouse made the computer a more user friendly environment and eliminated the need for huge stacks of punch cards to input data into a mainframe computer. Output of the computer calculations could be read on screen vice printing out large amounts of paper with graphic symbols on them

The Fourth Generation Computer (Early 1970s – Mid

1980s) The Microprocessor

Again an improvement on the previous generation, this generation continued to reduce the size of the silicon chip comparable to the size of a pencil eraser while vastly increasing its computational speeds. This single chip with the components and processing speeds of a computer was called a micro-processor and was initially intended for use in calculators, not computers.

During this generation the silicon chip technology was harnessed by the chip manufacturer Intel. Intel in partnership with IBM created the first microcomputer, or personal computer. A few years later Apple in partnership with Motorola introduced the Macintosh to compete against the IBM personal computer. Only recently has Apple recognized the need for standardization and has embraced the Pentium technologies currently supported by Intel.

During this period new and more powerful programming languages developed. This included Pascal, C and compilers which converted the program to a lower level language that the machine could process. The UNIX operating system was also developed during this time to manage system resources.

The Fifth Computer Generation Computer (Mid 1980s – Early

1990s) Artificial intelligence and Parallel Processing

The goal of this generation is to develop devices that are capable of responding sensibly to a user's natural language and also capable of learning and self-organization. It is characterized by the introduction of computers with hundreds of processors that could be assigned to work on different sections of a single program. This is called parallel processing, and is being used to develop communication between a computer in natural spoken language and its user, through access to a vast knowledge database to make intelligent inferences and draw logical conclusions in the way that humans do.

Several programming languages known as artificial intelligence (AI) languages have been developed simply because they are used almost exclusively for AI applications. The two most commonly used languages are LISP and Prolog.

The linking of computers together, called computer networks, and the increasing use of workstations (explained in table 2.1) were also developed during this generation.

Activity 2.1 - Consider the advantages and disadvantages of the development of artificial intelligence in this generation

Turn to Appendix One for Suggested Response

The Sixth Generation (Mid 1990s to Present) Computers and Video Games

This era refers to the generation of computer and video games which became popular around 1998. The Nintendo Game Cube, Sony PlayStation 2, and Microsoft's Xbox are noted to have dominated game playing in all age groups.

Figure 2.1: General Timelines of Computer Generations

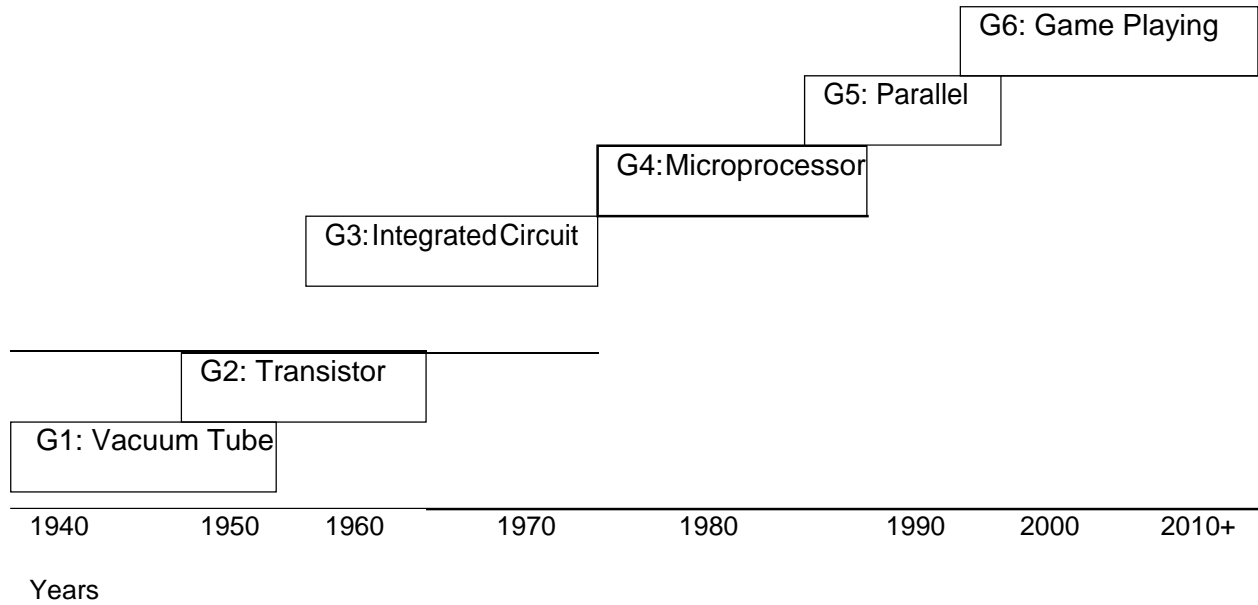

Activity 2.2—Reflect upon what facilitated the increase in speed, power or memory in each of the computer generations.

Turn to Appendix One for Suggested Response

Types of Computer Systems

In the past computers were classified as microcomputers, minicomputers, or main-frame computers, based on their size. Today these distinctions are rapidly disappearing as the capabilities of even the smallest units rival that of their earlier big brothers. Today's microcomputers are faster, more powerful and more versatile than the minicomputers and the main-frame computers were a few years ago. Table 2.X describes the terms used to classify today's computers and computing devices.

Type of Computer System	Brief Description
Desktop Computer	A PC that is expected to be placed on the top of a computer or other desk. Desktops usually are powerful and have reasonably large secondary storage. Desktops require a number of input and output devices to make them useful.
Laptop	Compared to the desktop, laptops are portable computers that have their monitor, keyboard, and other memory and storage devices all included in a package that is up to 17 inches in size and is powered by a special battery. Laptops are also called notebooks.

Type of Computer System	Brief Description
Mainframe	Mainly associated with large companies, that process millions of transactions calculations from multiple sources at one time, mainframes previously filled large rooms, but today consist of a number of linked components that allow the different processors to communicate with one another and share their total computing power.
Minicomputer	Minicomputers are powerful and can support many users at once. Their size is between microcomputers (PCs) and mainframes.
Palmtop	More commonly called Personal Digital Assistants (PDAs). They are compact computers that often use special secondary flash memory instead of a typical hard drive for storage. Palmtops usually have optional keyboards but mainly use touch screens for input. They are typically the size of a paperback novel or even smaller and are very lightweight and use battery power.
Personal Computer	Personal Computers (PC) was designed to be used by individuals for general use. The PC is not usually associated with the Apple Mac although it is a PC. Often the term desktop and PC are used interchangeably.
Server	A computer that has been optimized to provide services to other computers over a network. Servers usually have powerful processors, lots of memory and large hard drives. They often provide custom services such as an e-mail server, a backup server, a database server, etc.
Supercomputer	Supercomputers have the world's fastest processors and are able to perform millions of computations a minute. Supercomputers are normally comprised of multiple high performance computers working in parallel as a single system. The best known supercomputers are built by Cray Supercomputers.
Wearable computers	This is the latest trend in computing where common computer applications such as electronic mail, are integrated into watches, cell phones, visors and even clothing.
Workstation	A workstation is a desktop computer with a more powerful processor, and more memory for performing a special functions, such as 3D Graphics

Activity 2.3 - Explain, with reasons, which computer system(s) would be most appropriate in the following examples:

1. Business executive who travels often
2. Student who needs to prepare a History project report
3. A multi-million dollar company with six branches in the country and three in other countries
4. Banking system with many tellers who access the same customer database

Turn to Appendix One for Suggested Response

TOPIC SUMMARY

Since the 1940s when computer technology was used to support the creation of firing tables for the artillery and to the introduction of the World Wide Web network of computers in the 1980s computer technologies have become a large part of our everyday life. The use of computers is accelerating. They are now in our cars, our phones, our refrigerators. Almost every type of electronic device has a computer chip in it. Each chip relays on commands. Commands must be input using different devices. The next topic will examine some of these input and output devices.

TOPIC 2 – COMPUTER HARDWARE AND PERIPHERALS

INTRODUCTION

This topic presents a brief discussion on computer and their components and other basic concepts you need to familiarise yourself with before using the computer.

OBJECTIVES





Upon completion of this lesson you will be able to:

1. Distinguish between different hardware components of a computer.
2. Explain the functions/uses of the different components.

We have briefly looked at the different types of computer systems in Topic 1. We will discuss the different hardware components that make up different computer systems. The hardware and peripherals can be categorized as either Input, output, process or storage devices.

INPUT DEVICES

You use input devices to provide information to a computer, such as typing a letter or giving instructions to a computer to perform a task. Some examples of input devices are described in the following list.

<p>Mouse: A device that you use to interact with items displayed on the computer screen. A standard mouse has a left and a right button.</p>	
<p>Trackball</p> <p>This is an alternative to the traditional mouse and is favoured by graphic designers. It gives a much finer control over the movement of items on the screen.</p> <p>Other screen pointing devices are pointing stick, touch pad, joystick, light pen, digitizing table.</p>	 
<p>Keyboard: A set of keys that resembles a typewriter keyboard. You use the keyboard to type text, such as letters or numbers into the computer.</p>	

<p>Scanner: A device that is similar to a photocopy machine. You can use this device to transfer an exact copy of a photograph or document into a computer. A scanner reads the page and translates it into a digital format, which a computer can read. For example, you can scan photographs of your family using a scanner.</p>	
<p>Barcode Readers: When used in a business barcodes provide a lot of information. Made up of columns of thick and thin lines, at the bottom of which a string of numbers is printed.</p>	
<p>• Multimedia devices</p> <p>This is the combination of sound and images with text and graphics. To capture sound and image data, special input devices are required.</p> <p>Microphone: Voice input, for instance, can be recorded via a microphone. A device that you can use to talk to people in different parts of the world. You can record sound into the computer by using a microphone. You can also use a microphone to record your speech and let the computer convert it into text.</p> <p>Webcam: A device that is similar to a video camera. It allows you to capture and send the live pictures to the other user. For example, a webcam allows your friends and family to see you when communicating with them.</p> <p>Digital camera: A device that records photographs in the form of digital data that can be stored on a computer. These are often used to record photographs on identity cards.</p> <div style="display: flex; justify-content: space-around; align-items: center;">   </div>	

Take a few minutes to reflect on the content discussed so far.





Self-Reflection Activity

Look around in your immediate environment (shops, government institutions, at home, etc) and see if you can recognise any of the above discussed input devices. Can you remember the functions of each of the devices that you have identified?

Let's continue our discussion by looking at the second type of computer hardware.

OUTPUT DEVICE

Output devices in the computer system are the equipment whereby the result of a computer operation can be viewed, heard or printed. You use output devices to get feedback from a computer after it performs a task. Some examples of output devices are described in the following list.

	<p>Monitor: A device that is similar to a television. It is used to display information, such as text and graphics, on the computer.</p>
	<p>Printer: A device that you use to transfer text and images from a computer to a paper or to another medium, such as a transparency film. You can use a printer to create a paper copy of whatever you see on your monitor.</p>
	<p>Plotter: A plotter is an output device similar to a printer, but normally allows you to print larger images. It is used for printing house plans and maps.</p>
	<p>Multimedia Output Device: The most common multimedia output is sound, including music. The audio output device on a computer is a speaker. Headphones can also be used to receive audio output.</p>

Take note

One of the things that you need to make sure of is that you get the right printer.

How do you know what printer to get?

There are various types of printers available and these vary considerably in the quality of their production.

Impact Printers



Dot matrix printers are an example of impact printers. They form characters from patterns of dots. They are inexpensive, but the output can be difficult to read.

Non-impact Printers



Inkjet printers work by shooting a jet of ink in the shape of the character required, they provide good, low-cost colour printing.



Laser printers—a laser beam is directed at an electro-statically charged surface, creating a template of the page to be printed. This template is then used to transfer the ink to the page. Toner sticks to the light images and is transferred to paper.

PROCESS AND STORAGE DEVICES

The system unit is the name given to the main computer box that houses the various elements as illustrated in the picture below.

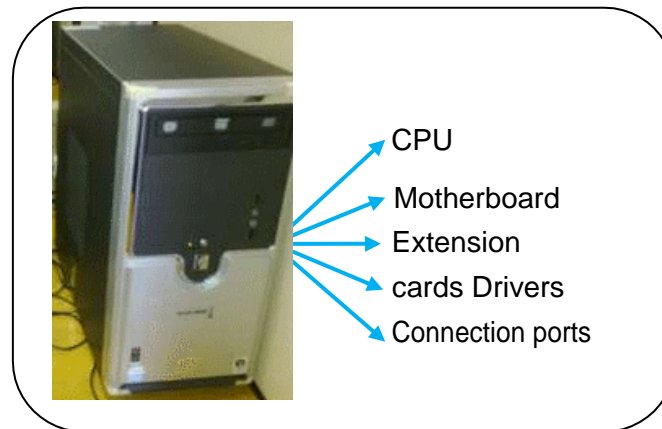

How do we get the different computer parts to work together so that your computer can work? Let's start our discussion with the process devices.

Motherboard



Inside the systems unit is a circuit board with tiny electronic circuits and other components which is called a motherboard. It is sometimes called a system board. The motherboard connects input (keyboard, mouse and scanner), output (monitor, speakers, and printer), processing (CPU, RAM and ROM) and storage (hard drive, CD-ROM/DVD-ROM)

and flash drives) components together and tells the CPU how to run (Lubbe and Benson, 2010:18). Other components on the motherboard include the video card, the sound card, and the circuits that allow the computer to communicate with devices like the printer.

Expansion Cards

Yes you can play music and video files on your computer. But how is it possible?

Inside the computer system box you also find an expansion card which is another circuit board that can be attached to the motherboard to add features such as video display and audio capability to your computer. Expansion cards are also called expansion boards that enable your computer to use the multimedia devices. An expansion card either improves the performance of your computer or enhances its features. Examples of expansion cards that can be added include:

- **Video Card:** It is connected to the computer monitor and is used to display information on the monitor.
- **Network Interface Card (NIC):** Remember we've explained computer networks in Unit 1. The NIC allows the computer to be connected to other computers so that information can be exchanged between them.
- **Sound Card:** It converts audio signals from a microphone, audio tape, or some other source to digital signals, which can be stored as a computer audio file. Sound cards also convert computer audio files to electrical signals, which you can play through a speaker or a headphone. The microphone and the speakers or the headphones connect to the sound card.

STORAGE DEVICES

All computers need to store and retrieve data for processing. The CPU is constantly using memory from the time that it is switched on until the time you shut it down. There are two types of storage devices as illustrated in the flow chart below.

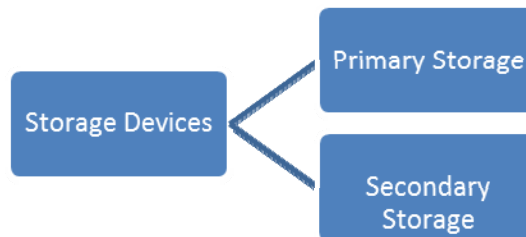

Primary Storage is also called main memory or immediate access store (IMAS). This is necessary since the processing unit can only act on data and instructions that are held in primary storage. Primary storage consists of two types of memory chips:

- ▶ Random Access Memory (RAM)
- ▶ Read Only Memory (ROM)



Random Access Memory (RAM) is the main working memory. RAM is only filled after a computer has been turned on and is given something to do. It holds data and instructions temporarily while processing takes place. RAM is volatile – this means that if the power is turned off or the computer reboots (start up again) all the information held in RAM will be lost. RAM is measured in MB (megabytes) and most entry level computers will have 1024 MB RAM but you also find some computers having up to 3 GB RAM. RAM chips are expensive and the price of a computer is determined by the amount of RAM space in the chip.



Read Only Memory (ROM) holds data and instructions necessary for starting up the computer when it is switched on. These instructions are hardwired at the time of manufacture. ROM is permanent and cannot be deleted but can only be accessed or read, hence the name Read Only Memory. Data stored in ROM is non-volatile – meaning that memory will not be lost when power is turned off.

So we can compare the features of the two memory types as below:

Fig. 2.1 Comparing RAM and ROM

RAM	ROM
Needs power	Does not need power
Data can be changed	Data can't be changed
Data will be lost if power is turned off	Data will not be lost if power is turned off
Volatile	Non-volatile
Stores data currently being processed	Fixed instructions is stored

[Source: Lubbe and Benson, 2010:20)

Units of Storage

The memory of all digital computers is two-state (bi- stable) devices. Computers operate using a **binary number system** – and therefore use *binary digits (bits)*. Bits have only two values by 0 and 1. **A bit** is the smallest unit of storage in a computer.

The amount of data and instructions that can be stored in the memory of a computer or secondary storage is measured in bytes.

A **byte** is made up of a combination of eight (8) **bits** and has the storage power to represent one character (a character is a letter or symbol or punctuation mark or blank space).



Units of Storage	
1 byte	8 bits
1 kilobyte (K)	1024 bytes
1 megabyte (MB)	1000 kilobytes (approx. 1 million bytes)
1 gigabyte (GB)	1000 megabytes (approx. 1 billion bytes)
1 terabyte (TB)	1000 gigabytes (approx. 1 trillion bytes)

Secondary Storage Devices

PCs use a simple method of designating disk drives to store data. These drives are assigned letters of the alphabet.

A Drive	Floppy drive. Still found in older computers
C Drive	Internal hard drive (hard disk drive) situated inside the system case.
D Drive	Usually the CD-ROM/DVD-ROM drive although can also be used for another virtual or physical hardware if a second one is deployed.
E Drive or Higher	Usually use for any other disks, such as CD-writer, USB flash drive, external hard drive, etc.

Data and information stored on a permanent basis for later use. Secondary storage is cheaper to purchase and access. Hard disks, Zip drives, Optical disks (CD's and DVD's) are all examples of secondary storage.

<p>Internal Hard Disks are rigid inflexible disks made of highly polished metal. Data is stored magnetically. They can contain a single disk or two or disks stacked on a single spindle. They come in a variety of sizes but all have a very high storage capacity compared to floppy disks. An average computer has a hard disk of about 80 - 250GB. It provides direct access to information.</p>	
<p>External hard Disks/Drive - same features as the internal hard disks, but are external to the system unit and therefore can be carried around. USB port is used to connect the external hard drive to the</p>	

<p>Optical Disks are disks that are read by laser beams of lights. The three main types are CD-R, CD-RW and DVD.</p> <ul style="list-style-type: none"> • CD-R or CD-ROM (Compact Disk–Read Only Memory) are so called because you can only read the information on the CD-ROM. They are particularly useful for storing multi media (texts, graphics, sound and videos), application software packages (encyclopaedias, training programs etc). • CD-R or Compact Disk Recordable allows you to write information onto the disk only once using a CD recordable burner. 	
<ul style="list-style-type: none"> • CD-RW or Compact Disk Rewriteable, allows you to write and erase information from the disk many times. They are used to store large volumes of information such as texts, graphics, sound and video. • DVD disks or Digital Versatile Disks are specifically created to store movies. A typical DVD disk can hold between 4.7GB and 17GB of information. 	
<p>USB flash drive – consists of a flash memory data storage device integrated with a USB (Universal Serial Bus) interface. USB flash drives are typically removable and rewritable. They come in a variety of sizes to include 128MB, 256MB, 512MB, 1G, 2G, 8G etc.</p>	
<p>Memory Card - Use mainly with digital cameras, cellular phones and music players (MP3, MP4 and iPods). They offer high-re- record ability and fast and power-free storage. Data can be access by linking the card to a computer using a USB cable or a memory card reader.</p>	

Now that you have a basic understanding of the hardware components of a computer take some time and do the following activity.

Activity 2.4

A. Test your knowledge. Say whether the following statements are true or false.

Turn to Appendix One for Suggested Response

	T	F
1. RAM is memory where fixed instructions is being stored		
2. Data is another word for information		
3. A byte of memory can store an entire word		
4. DVD's are used mainly for storing movies		
5. Data on CD-R disks can be erased and rewritten		
6. Back up files are usually created on hard disks		
7. The smallest unit of data is a bit		
8. ROM is volatile memory		
9. Trackballs, pointing sticks and touch pads do the same function as a mouse		
10. Input devices take raw data and turn it into information		
B Answer the following short questions.		
<ol style="list-style-type: none"> 1. What is the main purpose of a CPU 2. Distinguish between RAM and ROM. 3. Define input and output devices and give examples of each. 4. Name one device that can function as both an input as well as an output device. 5. What does 'bits' stand for? 		

Did you do well in answering the questions? Please work through the unit again if you feel that you did not master the content yet. Let's summarise what we have discussed in this topic.

TOPIC SUMMARY

In this topic we have learned that:

- Computer hardware consists of input, output, process and storage devices.
- You use input devices such as keyboard, mouse, scanner and multimedia devices to provide information to a computer.
- Output devices are used to get feedback from a computer after it performs a task. Examples include monitor, printer and multimedia devices.
- CPU takes raw data and turns it into information. The CPU is made up of Control Unit, Arithmetic Logic Unit (ALU) and the main memory.
- Storage devices are divided into primary and secondary storage devices.
- Primary/main memory is subdivided into ROM and RAM.

- Random Access Memory (RAM) is the main memory and allows you to temporarily store commands and data.
- Read Only Memory (ROM) retains its contents even after the computer is turned off.
- A bit is the smallest unit of storage in a computer.
- **The amount of data and instructions that can be stored in the memory of a computer or secondary storage is measured in bytes. A byte is made up of a combination of eight bits and has the storage power to represent one written character.**
- Hard disks, CD-R, CD-RW and DVD are secondary storage devices.

This brings us to the end of topic 2.1. We've said earlier that for you to be able to use your computer you will need the programmes to operate the computer. Let's move on to the next topic where we can look at how the computer hardware processes information.

Unit 7: Computing and Data Processing



INTRODUCTION

This unit discusses explains how a computer processes data that executes different computer instructions.

UNIT OBJECTIVES

At the end of this unit, you should be able to:

1. Describe about computing process of computers
2. Explain how a computer processes data.

This unit is divided into three topics:

Topic1: Computers and Computing

Topic2: Data Processing

TOPIC 1 - COMPUTERS AND COMPUTING

INTRODUCTION

This topic explores the types of computer systems (vice individual computers), their purpose, their structure and it provides a technical description of the components of a generic computer system.

OBJECTIVES

After studying this topic, you will be able to:

1. Distinguish between a computer and a computer system.
2. Explain the term general computer system.
3. Explain the term embedded system.
4. Show diagrammatically the components of a computer system.
5. Describe a central processing unit (CPU).
6. Explain arithmetic and logic unit (ALU).
7. Define primary memory and how it functions.

GENERAL PURPOSE COMPUTER SYSTEMS

When you look at a desktop computer, it comprises a monitor, keyboard, mouse, and a vertical or horizontal box called a system unit. It is acceptable to refer to all of these components as a computer. Technically the system unit houses the actual 'computer' or programmable machine (hardware, firmware and software), which executes (carries out) or responds to a sequence of program instructions. A computer system then is a collective term for a computer (housed within the system unit), as well as these other components that are attached to it to allow the user to input data and view output using different devices. Some of these components include a monitor, keyboard, mouse, printer, disk drives, scanners, microphones, and speakers, which are also referred to as peripherals. The peripherals work together to help the user accomplish a given task effectively. Therefore, as an example, when you perform a calculation, the keyboard – a peripheral device – is used to input the data. It is the system unit that accepts and processes the data, and generates the results. Other peripheral devices such as the hard drive store the data and results, which can be viewed on the monitor.



The peripheral devices mentioned above are collectively called hardware devices, since they can be physically attached to the computer. However, computer systems also include software, or programs that are integral in the functioning of some of these peripheral devices and are necessary to make the computer operate. Every computer system, for example, requires an operating system. An operating system is a program that establishes communications with the various peripherals and acts as a bridge to other application specific software programs. An operating system is like the command centre of the ship. It makes all of the decisions about how the computer will function and work with others.

EMBEDDED COMPUTER SYSTEMS

The typical personal computer or laptop described in the last discussion is categorized as a general-purpose computer system. This section will explore a special type of computer system called an embedded system. Embedded systems are designed to perform a very small number of very specific functions. For example a GPS computer in a car only provides driving instructions. It cannot perform any other computing function. A typical embedded system also uses certain types of hardware, and limited resources, such as small keyboards, screen and reduced memory. These systems are also actually built into the device they are controlling.

Compared to a typical computer, embedded systems are often smaller in size, tend to be cheaper, and as a result many are mass-produced. Embedded systems range from small portable devices to large complex systems. The major difference is that they are single purpose devices with only one form of input or output. Some may also have simple user interfaces or displays which include buttons, or touchscreens, while others have none at all.

Table 2.1 - Examples of systems and devices which comprise embedded systems

Portable devices	Large complex systems
Digital watches	Traffic lights
MP3 players	Systemscontrollingnuclearpower plants
Microwave ovens	Controllersusedinremote machine operation
Washing machines	Navigation Systems
Television sets	Military Weapons Systems
DVD players	
Air conditioners	
Sprinklers	
Security monitoring system	
Handheld computers	
Thermostats	

Activity 2.5 – Try and think of other examples of embedded systems that you typically use in your day to day activities but have never thought of them as embedded computer systems.

Turn to Appendix One for Suggested Response

Mobile (cellular) phones and handheld computers may be categorized as embedded systems, but since these devices can be enhanced with the addition of other applications and peripherals, they are better suited to the category of general purpose computer systems and not really embedded systems.

COMPUTER SYSTEM – HOW IT WORKS

The major components of a computer system include input and output devices as well the important processor or central processing unit (CPU). The CPU comprises a set of electronic circuits kept within the system unit. The CPU is the brain of a computer system and is responsible for processing the data that is input from a peripheral device and output to

another peripheral device. Figure 2.2 illustrates the major components of a system unit that is attached to an input and output device.

Figure 2.2: Central Processing Unit

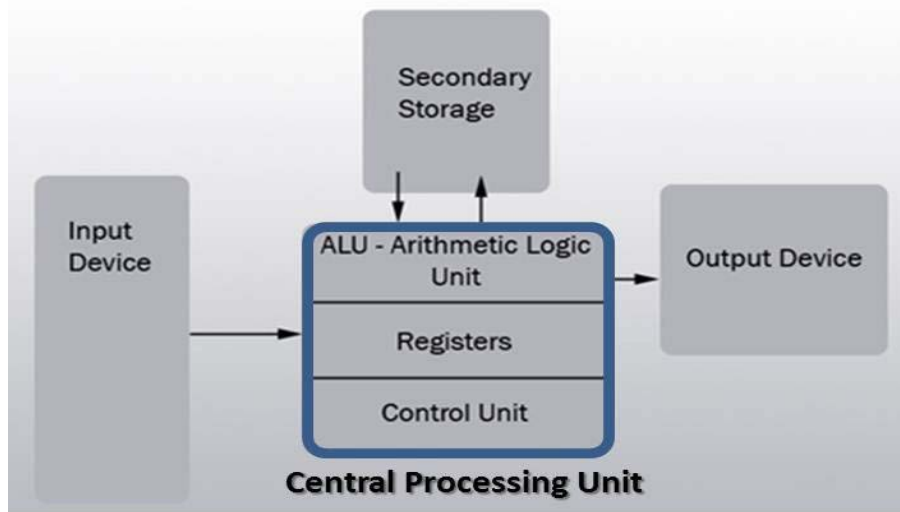

The Central Processing Unit (CPU), also known as the processor or microprocessor has components that control the operating system and other software installed on the computer. The CPU also sends commands and data to the peripherals attached to the computer, such as the monitor or printer. Therefore the speed (how fast the electrons move around the chip) at which the CPU executes its tasks (or commands) determines how quickly you can view or hear the output from the command; such as printing a page or allowing you to view a letter on the monitor. This speed is called 'clock speed', and is measured in megahertz (MHz). A computer system that responds to commands quicker means that its clock speed is working faster to execute these commands. Table 2 compares some common CPUs and their clock speeds. Different CPUs use different silicon chips to execute the commands and process data. Different types of chips have different clock speeds based on the technology that was used to create them. Some examples are provided below.

Table 2.1 Typical CPU Speeds Based on Chip Type

Name of CPU	Average CPU Speed
Intel Celeron	500 MHz - 800 MHz ¹
Intel Pentium II	233 MHz - 450 MHz
Intel Pentium III	450 MHz - 1 GHz ²
Intel Pentium 4	1.4 GHz - 2 GHz
Intel Core i7	3.6 Ghz
AMD Athlon XP	1.4 GHz - 1.8 GHz
Macintosh G4	733 MHz

Now let's look deeper into the operation of the CPU. All computer systems have a CPU which comprises (1) a control unit and (2) arithmetic and logic unit (ALU).

The Control Unit (CU)

The control unit is similar to an efficient manager. It is responsible for directing other parts of the computer system in order to carry out the instructions for the task required. The control unit (CU) must interact with the arithmetic and logic unit (ALU) and memory to complete its tasks. As instructions are fetched from memory, the CU interprets the instruction. The CU then sends commands to other components to gather data that may be needed to complete the instruction, even if it involves a transfer of data from other components and devices. The CU then determines where to send the result. This may

¹ Mhz = Megahertz - It is a measure of the transmission speed of electronic devices, including channels, buses and the computer's internal clock. A one-megahertz clock (1 MHz) means some number of bits (16, 32, 64, etc.) are manipulated one million times per second.

² Ghz = Gigahertz - A one-gigahertz clock (1 GHz) means one billion times. MHz and GHz are used to measure the speed of the CPU. For example, a 1.6 GHz computer processes data internally (calculates, compares, etc.) twice as fast as an 800 MHz machine. However, the doubled clock speed of the CPU does not mean twice as much finished work gets done in the same time frame. Internal cache design, bus speed, disk speed, network speed and software design all contribute to the computer's overall processing speed and performance (overall throughput).

include activating the printer, showing the result on the monitor or playing a sound on the speakers.

Activity 2.6 - Explain why the control unit is regarded as an efficient manager.

Turn to Appendix One for Suggested Response

Arithmetic and Logic Unit (ALU)

The Arithmetic and Logic Unit (ALU) is the part of the CPU which performs all arithmetic and logic operations this involves arithmetic calculations including addition, subtraction and multiplication. As calculations are required, the Control Unit sends them to be performed in the ALU which sends the result back to the Control Unit. It also performs logic operations such as comparisons of numbers or letters to test for, such as equal-to (=), less-than (<), greater-than (>) and other combinations, such as less-than or equal-to (<=).

Activity 2.7 - In a test for the equal-to condition, the arithmetic/logic unit compares two values to determine if they are equal. For example: If the number of tickets sold (Num_Tickets) equals the number of seats in the auditorium (Num_Seats), then the concert is declared sold out. This can be represented as:

Num_Tickets = Num_Seats ?

The result can be:

- True or Yes, indicating that the concert is sold out or
- False or No indicating that the concert is not sold out.

Write the corresponding representation for the following examples:

1. Credit card limit is greater than \$3000
2. Votes for Candidate A are less than the votes for candidate B
3. Test mark is greater than or equal to 50

Turn to Appendix One for Suggested Response

Memory

Primary memory is necessary to store instructions and data for processing, but they are not part of the CPU. Memory are separate chips stored on a mother board which connects all the hardware together. Program instructions or data are kept in primary memory for only as long as the program currently using them. In human terms this would be considered

“short term memory”. The original instructions and data are lost once the computer is turned off; therefore primary memory is deemed volatile. In later units we discuss those non-volatile devices which allow data and instructions to be permanently stored in a computer system for use later on. Primary memory is also as – memory, main memory, primary storage, main storage, internal storage, computer memory and RAM (Random Access Memory).

Activity 2.8 - Explain what is meant by the phrase “primary memory is deemed volatile”

Turn to Appendix One for Suggested Response

TOPIC SUMMARY

The internal workings of a computer are very similar to the internal workings of the brain. The CPU represents the brain. Both are used to store and process information. Both carry out complex algorithms to store and combine crucial information. Both control the external operation of the body or in the case of the computer the peripherals and other attached devices. How this is done will be explored in the next topic on data processing.

TOPIC 2 – PROCESSING DATA

INTRODUCTION

Processing data is the most important activity in the computer, and so the task of the processor is to interpret and execute program instructions, in order to transform data into information. The processor is also responsible for interacting with the input, output and storage devices.

Objectives

After studying this topic, you will be able to:

1. Describe the function of the machine cycle.
2. Describe how data moves through the Central Processing Unit (CPU).
3. Define megabyte.
4. Explain the difference between RAM and ROM.
5. Describe the machine cycle.
6. Describe what happens in the instruction and execution phase.
7. Explain the difference between instruction time (i-time) and execution time (e-time).
8. Define memory addressing.

PROCESSING DATA AND COMPUTER MEMORY

Keeping instructions and data in primary memory when a program is not in use is not feasible for three reasons:

- The processed data may be too much to be held in primary memory.
- Generally primary memory only stores data and instructions while the computer is turned on, but once the computer is turned off, the data and instructions are lost.
- If more than one program or application is opened at the same time, then, a single program should not exclusively use all the memory; some memory should be available for the other programs to use.

The amount of memory available to hold the data and instruction is measured in *megabytes* or MB. A personal computer with a minimal amount of memory of say less than 512 MB may not be able to perform efficiently and may be rather slow in executing the applications. Memory is also loosely known as RAM which is an acronym for *Random Access Memory*. It should be noted there that the word *random* implies that data can be retrieved quickly, and in the same length of time, regardless of where the data is located (that is, the address of the data).

Read Only Memory (ROM)

Read-only memory or ROM is an integrated circuit, programmed with specific data when it is

manufactured. It is used in computer systems and other electronic devices. RAM and ROM are different since data stored in ROM cannot be modified easily. In other words, ROM is ideally suitable for storing a set of data for the life of the device, and is therefore non-volatile.

Modern types of ROM include such as Programmable ROM (PROM), Erasable Programmable ROM (EPROM), Electrically Erasable Programmable ROM (EEPROM) and flash memory can be erased and re-programmed many times, although they are still called ROM because the reprogramming process is usually rarely done. Many ROM chips are often identified by the prominent circular 'window' which allows ultraviolet (UV) light to enter and erase its contents.

Flash memory (or simply flash) is a modern type of EEPROM which can be erased and rewritten faster than EEPROM. Flash memory is mainly used in memory cards, USB flash drives, memory stick, flash stick and jump drive), which are used for general storage and transfer of data between computers and other digital products.

Function of the Machine Cycle

Consider a user who needs to add two numbers, 10 and 15. These numbers may be input at the keyboard and the results shown on a screen. The processing of this simple addition is carried out in the CPU.



Let us examine how a single instruction is executed or carried out in the central processing unit. Of course, computers today generally execute one instruction at a time, although as quickly as a fraction of a second.

In order to carry out an instruction, the program instructions and data must be moved into memory from either an input device or a secondary storage device. Once in memory, the control unit and ALU in the CPU work together to perform the following four steps (fetch, decode, execute, and store) for each instruction. These steps are collectively known as the machine cycle or the processing cycle. This machine cycle has two phases, the instruction cycle (instruction time, or I-Time) and the execution cycle (execution time or E-Time). Let us examine these cycles in more detail.

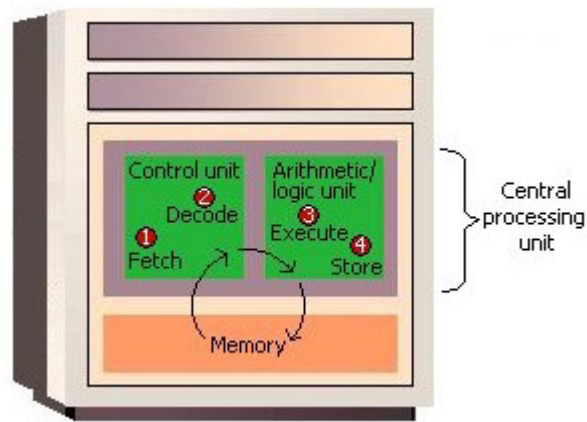

Phase A: Instruction Cycle

1. **Fetch Instruction:** The control unit fetches (gets) the program instruction from memory.
2. **Decode Instruction:** The control unit decodes the instruction (decides what it means) and then moves the necessary data from memory to the ALU.

Phase B: Execution Cycle

3. **Execute Instruction:** The ALU performs the requested action, by executing the arithmetic or logical instructions on the data.
4. **Store (write) Result:** The ALU writes or stores the result of this operation in memory or in a temporary register.

Once these two phases are complete, the control unit instructs memory to send the result to an output device or a secondary storage device. The figure below illustrates how these cycles interact to produce a result.

Activity 2.9 - Describe briefly the four basic operations that comprise a machine cycle or instruction cycle.

Explain the difference between instruction time (i-time) and execution time (e-time). **Turn to**

Appendix One for Suggested Response

We have already noted that the Control Unit is ideally the brain of the CPU, and must be very organized. For all instructions to be processed the Control unit must have the data ready and the cycles working like, well, like clock work! If the control unit is regarded as the brain, then the clock is regarded the heart of the computer. Every operation in the processor takes place like the ticking of a typical old-fashioned mechanical clock. Each 'tick' may indicate the beginning and each 'tock' the end of a basic interval of time in the processor during a clock period. During this beginning and end phase, data moves as directed from the CU.

We have discussed instructions, data, and memory, as well as the machine cycle functions in two phases. Let us now briefly mention how the control unit is able to retrieve the correct data and instructions from memory. This is done by giving each instruction and each piece of data an address, just as persons have an address for their home. So the addresses say the same, but just as people move to new addresses, different instructions and data are moved to new addresses or locations when the old data is no longer needed in memory. Just like a mailbox for an address can hold so many letters and packages, similarly each memory location can also only contain a fixed amount of data. Finally as mailboxes may have a label or number affixed to it, so do memory addresses have representative address names such as Hours, Age, or Name.

Activity 2.10 - Explain in simple terms, what is understood by a memory address **Turn to**

Appendix One for Suggested Response

A memory address is simply a unique number that identifies the location of a particular byte in memory.

Turn to Appendix One for Suggested Response

TOPIC SUMMARY

This topic explored how data is processed, calculated and stored in a computer. Understanding this process will help you better understand the type of systems and system software that you need to support your business.

RECOMMENDED UNIT READINGS

After you have completed your review of each Topic and its related activities, it is recommended you read at least one of the following online articles and consider the related reflective questions as you read the materials.

Kopplin, J. (2002). An Illustrated History of Computers. Computer Science Lab. Retrieved November 10, 2007 from:
<http://www.computersciencelab.com/ComputerHistory/History.htm>.

There are four parts to this article. Kopplin demonstrates that computers are not a new invention. Devices to perform calculations have existed for over two thousand years. The four parts provide a pictorial history of our early computers. When reviewing the Kopplin article consider:

“The history of mankind is one of innovation, revolution and change”. How does the evolution of computer devices support this statement?

Beach, T.E. (2004). Hardware. In Computer Concepts and Terminology. University of New Mexico at Los Alamos. Available at:
<http://www.unm.edu/~tbeach/terms/hardware.html>.

This article is part of a larger tutorial on computer concepts presented by Dr. Beach. Feel free to review other parts of his tutorial. When doing so consider:

What is the basic configuration of the computer that you are currently working on. Can you identify the different components and the capabilities of each component?

UNIT SUMMARY

The following concepts were covered in this unit:

- ❑ A computer is a device that accepts data, uses a program to process the data, and generate results.
- ❑ A computer system is a collective term that includes a computer and all peripheral devices attached to it, such as a monitor, keyboard and mouse.
- ❑ An embedded system is a special-purpose computer system designed to perform a dedicated function
- ❑ The main components of a computer system include the Central Processing Unit (CPU), primary memory, input and output devices, and secondary storage.
- ❑ The Central Processing Unit (CPU) comprises the Arithmetic and Logic Unit (ALU) and the Control Unit (CU).
- ❑ The ALU is the part of the CPU which performs all arithmetic and logic operations this involves arithmetic calculations including addition, subtraction and multiplication, as well as comparison of numbers and text.
- ❑ The control unit is responsible for directing other parts of the computer system in order to carry out program instructions
- ❑ Both primary memory and secondary storage are also necessary to store instructions and data for processing, but they are not part of the CPU
- ❑ Each new computer generation improves on its previous generation, by reduction in size (or miniaturization) of computer circuitry
- ❑ First Computer Generation is characterized by the huge vacuum tubes whose main purpose was to strengthen weak signals for transmission, and used switches to start and stop the instant flow of electricity
- ❑ Second Computer Generation replaced vacuum tubes by a much smaller transistor.
- ❑ Third Computer Generation produced and compacted millions of transistors on to an integrated circuit.
- ❑ Fourth Computer Generation is instrumental in the invention of the microcomputer, also known as a personal computer
- ❑ Fifth Computer Generation is developing communication between a computer in natural spoken language and its user

- Sixth Generation refers to the generation of computer and video games
- Primary storage is used to temporarily hold data and instructions
- Primary memory is known by other terms which are used interchangeably – memory, main memory, primary storage, main storage, internal storage, and RAM (Random Access Memory).
- In order to carry out an instruction, the program instructions and data must be moved into memory from either an input device or a secondary storage device
- The control unit and ALU in the CPU work together to perform the following four steps (fetch, decode, execute, and store) for each instruction

In this unit, the evolution of computer systems through a number of different generations was considered. Although it may appear to many as simply a historical perspective, it is important to view this history as clues for the underlying trend that brought computer systems to what they are today. This trend illustrates the reduction in size at each stage which also coincided with increased speed of the system designed to handle the many tasks required of it in this latest generation.

We also explored the distinction between a computer and a computer system along with introducing the concept of special-purpose computer systems. We also explored the components of a general computer system and their inter-connections and reliance on each other. Finally a description of how a computer processes data was explained.

Unit 8: Software

INTRODUCTION

This unit discusses the two categories of software that are used to actually have the computer complete specific tasks and that communicate with the hardware and other peripherals. The two categories of software are: systems software and applications software.

System software comprises a collection of programs with instructions that work together with the hardware components of a computer (including peripheral devices), to accomplish its tasks efficiently and effectively. System software acts as a mediator between the hardware resources and the application programs. In addition, system software monitors the activities of the computer (like memory and file storage) so that it functions efficiently.

Three major categories of system software are:

- Operating systems (OS),
- Utility programs, and
- Language translators.

Application software allows the computer user to create documents, produce graphics, capture and manipulate photographs, create databases and treat the computer as a tool for a variety of tasks.

The difference between the two can be summarized as follows: application software is what users require to complete their tasks while system software is the software that interfaces between the hardware to perform what is requested by the application software.

UNIT OBJECTIVES

At the end of this unit, you should be able to:

1. Explain the purpose of system software.
2. Distinguish among the three major categories of system software.
3. Explain the interaction between the user and the computer and the role of system software to support this interaction.
4. Explain the different types of useful application software.
5. Explain the word processing document life cycle.
6. Explain the purpose of spreadsheets in business.
7. Describe a statistical application that is used to analyze data.

This unit consists of two topics:

Topic 1 - Operating systems, utility programs and language translators. Topic

2 - Application software.

TOPIC 1 - OPERATING SYSTEMS, UTILITY PROGRAMS AND LANGUAGE TRANSLATORS

INTRODUCTION

There are three different types of software that are part of all computer systems and that ensure that the hardware and application programs can effectively communicate with each other. This software is classified as operating systems, utility programs and language translators.

OBJECTIVES

After studying this topic, you will be able to:

1. Describe the purpose of system software.
2. Explain the purpose of the different operating systems.
3. Describe the various user interfaces.
4. Explain the purpose of utility programs.
5. Describe characteristics of language translators.
6. Show diagrammatically basic file and data management structures.
7. Carry out basic file and data management operations.

OPERATING SYSTEMS

A computer cannot work without an operating system! The operating system comprises a set of coded programs that work with the peripheral devices and computer hardware to control and organize the general operating functions of the computer. Some of these functions include:

- Starting the computer (also called 'booting'),
- Managing and monitoring other programs, memory management, communications management and the management of peripheral devices,
- Enabling interaction between the user and the computer system through the use of external input devices, and
- monitoring and security of access to data and applications.

Starting the Computer

Starting the computer, also called *booting*, is the process of loading the operating system into the computer's memory so it can execute the different operations and manage the hardware devices. When the power button on the computer is turned on to load the operating system, this process is called a cold boot. If the computer system is already on and the system needs to be re-started for a number of reasons (like the hardware stops operating or the user gets an error message), then the process of reloading the operating system is called a warm boot (because the computer was already on). A warm boot in a Windows based PC is normally done by holding down the CTL-ALT-DEL keys at once.

Managing Other Programs

The computer system needs to manage the programs that the computer user needs to complete business or personal tasks such as a word processing, Internet research, spreadsheet production and others. The operating system must therefore be able to manage one or more software application programs at the same time. This is known as multi-tasking and the computer is considered a multi-tasking operating environment. For example, multitasking operating systems run more than one application program at a time. Suppose a user has a word processing program, Internet browser and a spreadsheet are open at the same time and the computer user currently typing a report, using the word processing program. The word processing program is called the active program, since it is the current program in use while the other programs – the Internet browser and spreadsheet – are called inactive programs since they are running in the background and are not currently in use.

Since computers use primary memory to increase processing efficiency, the operating system allocates memory spaces for each running program so that the individual programs do not interfere with each other. In order to accomplish this, the operating system uses 'virtual memory' or secondary storage, as an extension of random access memory (RAM). This is illustrated in the figure 3.1. Sometimes, if there are too many applications opened, then the operating system is unable to allocate adequate memory to each application.

When this happens, none of the applications may appear to work and the computer system may need a warm boot.

Figure 3.1 – Memory CPU Interaction

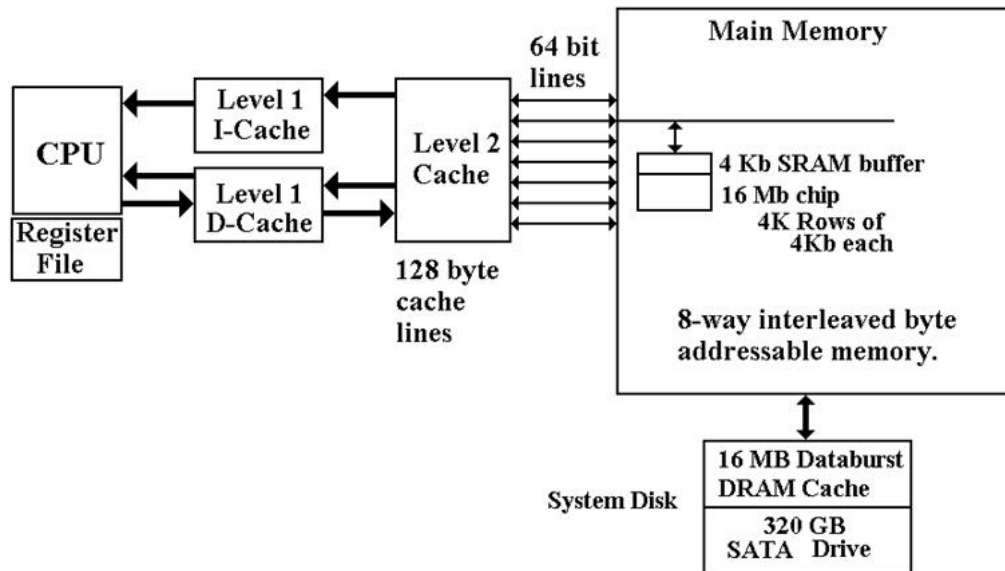

TYPES OF OPERATING SYSTEMS

Now that the purpose of an operating system has been explained, let us examine some operating systems that were developed for specific purposes.

The Macintosh (or Mac) and the IBM personal computer operate with hardware and software configurations. This is known as the platform. The platform of a computer system is the underlying hardware and software that it allows it to function. For example, the Apple computer was developed with a Mac platform using Motorola chips and unique operating software called "Mac OS". The original IBM computer uses Intel chips and originally employed an operating system called "DOS".

or Disk Operating System. Today's PCs now use a Windows based operating system that incorporates many of the original concepts in DOS. Operating systems differ in functionality, flexibility and ease of use. Today there are a number of different operating systems in use. They can be classified as either personal operating systems, network (client/servers) operating systems and handheld operating systems. A representative list of different operating systems is described below.

Operating System (OS)	Type	Main Purpose or Major Development
UNIX	Network	These are network operating systems that are powerful. Runs on many types of PCs, mainframes and workstations; is the primary operating system for Internet servers; first multitasking system, widely used by large corporations
Operating System (OS)	Type	Main Purpose or Major Development
Linux	Network	Uses a command line interface; more stable than Windows, but applications using Linux are rare.
Macintosh (MAC) OS X	Personal	First operating system to be developed that used a graphical user interface. Also considered the easiest system for beginners
Microsoft Windows 95, 98 and XP	Both personal & network	Capable of Internet browsing, and multimedia support. None of these earlier versions of Windows are supported by Microsoft.
Microsoft Windows NT/2000	Network	Also network operating systems that were designed specifically for corporate and other large businesses, and were also known as client/server systems (one computer 'serves' provides applications for many users 'clients'). Offered enhanced security, and remote access to computer systems among other features
Microsoft Windows Mobile 7	Handheld and Cell Phone	Supports handheld devices and smartphones. Supports integration with other Microsoft software.
Microsoft Windows 7	All Types	The current Microsoft operating system with a number of variants which can be used in all types of computer environments.

FUNCTIONS OF AN OPERATING SYSTEM

Birbal and Taylor, (2004: 39-40) summarise the functions of an operating system as follows:

1. Managing computer resources

The operating system allows application software programmes such as word processing, spreadsheet and database packages to communicate with the computer's hardware. For example if you work on a document in Excel and you want to print the document, you just press the print button on the toolbar. Excel will direct the operating system to select a printer to print the document. The operating system then notifies the computer to begin sending data and instructions to the appropriate program to get the document printed.

The operating system therefore acts as an interface between the application programmes and the hardware.

2. Managing files and memory

The operating system manages all files on a computer. It keeps tracks of the locations where programmes and data are stored within the computer's memory. For example, when you open a file that has been saved to the hard drive, you are first instructing the computer to find the file, and then to open it. The operating system also allows you to easily find files stored in secondary storage devices. Other file management functions include copying, erasing, renaming and backing-up files.

3. Maintaining security

In networks and larger computers each user is given a user name or ID and password to gain access to the computer system. The operating system keeps a register of all these names so that only persons with valid usernames and passwords can access the system. This prevents access by hackers and unauthorised persons.

The operating system also keeps a log which records users logged in, the length of time each user stayed on the system, and what they did. Administrators can check the log to look for security breaches and abuse of resources.

A hacker is a person who tries to gain access to a computer system without authorisation. Hacking is illegal in most countries.

4. Managing tasks

A computer can perform many tasks simultaneously. One way of doing this is multi-tasking – ability of the computer to run more than one programme at the same time. For example, a user can listen to music on his/her computer whilst at the same time typing a document or typing an e-mail while another e-mail is being sent. In the case of networks the multi-user operating system allows more than one user to access the same data at the same time.

5. Providing a user interface

Many operating systems functions are never apparent on the computer's display screen. What you do see is what is called the user interface. The interface helps the user to interact with the computer.

Activity 3.1 – Consider the following:

1. Identify a number of tasks that are carried out by all operating systems.
2. Describe at least one task that a multi-tasking operating system would be able to execute.
3. Describe at least one task that a multi-user operating system would be able to execute.

Turn to Appendix One for Suggested Response

USER INTERFACE

In order to interact with the computer, a user uses a part of the operating system called a user interface. The functions of the user interface are to start application programs, manage secondary storage, such as hard disks, as well as manipulate files and folders, and finally shut down the computer safely.

The three principal types of interfaces include:

- Graphical User Interface (GUI),
- menu-driven interface, and
- command-line interface.

The Graphical User Interface (GUI) uses graphics or icons which represent various tasks. For example the icon to print is a small picture of a printer  which when clicked with a mouse, will invoke the printing dialog box. Once the printer dialogue box is opened you can pick other commands that will be used to send your document to the printer. A GUI is a user-friendly interface that eliminates the need to remember complex computer commands or programming languages.



Figure 3.2 – Graphical User Interface Example

The menu-driven interface is used to show all of the options available to the user in the form of pull-down or pop-up menus. An illustration of a pull-down menu is shown in figure

Many menu interfaces now include the GUI icons with text menu options.

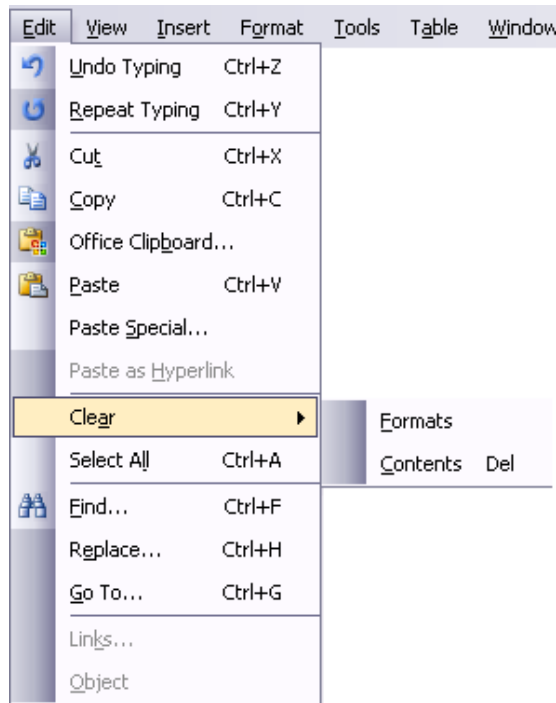

Figure 3.2 – Menu Driven Interface Example

The command-line interface requires the user to type keywords or commands at a prompt, in order to enter data or execute commands. You can experience this type of command when you open the “Run” interface to input DOS based commands to execute an operating system task. This interface is the most difficult one for the average computer users to learn. They are often used in programming applications or in support of systems software.

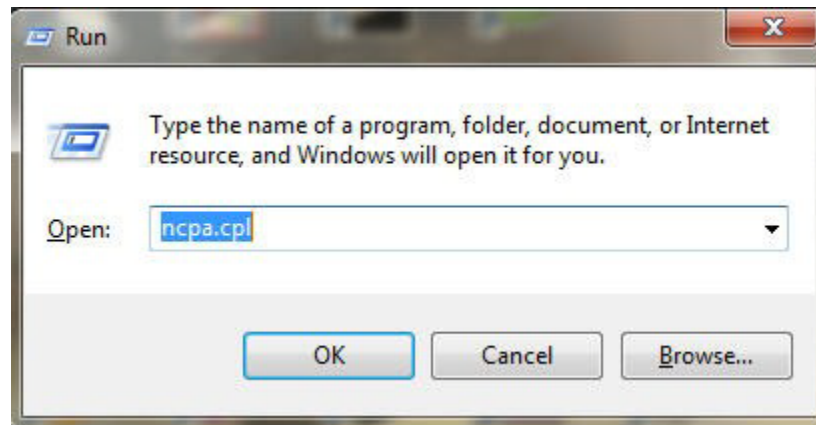

Figure 3.3 – Command Line Interface Example

Activity 3.2 - Graphical user interfaces (GUIs) are found on many computers. Why do computers need a user interface?

Think of other input devices, other than a keyboard, that can be used with a graphical user interface.

Turn to Appendix One for Suggested Response

UTILITY PROGRAMS

Utility programs are tools that help the operating system manage the computer system's secondary or non-priority jobs. These jobs are repetitive in nature. Some examples of utility programs include antivirus software, backup software, disk defragmentation, disk scanning; file compression software, file management programs, and searching software. Often are automatically loaded into memory when the system is booted and they operate in the background at the same time as the application program. Often you do not know they are working until they send you a message like "Virus detected, click here to eliminate". Only then does the user need to engage some form of interface to take the appropriate action.

Table 3.1 – Examples of Utility Programs

Utility Program	Description
Antivirus software	Protects the computer from computer viruses. Examples are Norton and Zone Alarm.
Backup software	Used to copy data from the hard disk to another storage medium.
Disk Defragmentation	Re-organizes data on a storage device to improve performance.
Disk Scanning	Involves disk-scanning utilities to detect and fix errors on storage devices, or disk cleanup utilities that remove unused or unnecessary files that are no longer needed.
File Compression	Reduces the size of a file, folder or directory. Popular utility is WinZip.
File Management	Stores files in a hierarchical structure, to enable various tasks such as creating, deleting, copying and moving files, folders, and directories
Search programs	Used to find files, folders or directories on storage devices.

Activity 3.3 - You share a computer with four other family members. Over the last three months, you notice an increase in files, and folders from the various projects and assignments. There are also quite a few files which have been downloaded from the Internet. Think about which utility programs would be appropriate, not only to organize the many files and folders, but to generally use on this computer.

Turn to Appendix One for Suggested Response

LANGUAGE TRANSLATORS

Language translators convert the data in a program (source code) into machine language code (object code) so that the computer can then process. The main purpose of translating source code to object code is to create a program in machine language so that the computer can produce the desired results. An example of different types of language translators are compilers and interpreters. The compiler is a computer program or in some cases a set of programs that translates another program's source code into object code all at once, while the interpreter is a set of programs that translate the application program's source code, one line at a time while the program is running.

TOPIC SUMMARY

While the CPU is the brain of the computer, it needs instructions to work effectively. It uses electronic instructions or binary signals in bits and bytes to communicate with other parts of the system. Software, specifically operating software, provides specific instructions to the peripherals and the various systems attached to the computer including network operations. Application software provides the creative portion of the brain. It allows you to use the computer to create and communicate. We will now explore application software.

TOPIC 2 – APPLICATIONS SOFTWARE

INTRODUCTION

Application programs assist the user in completing workplace tasks, personal tasks or research when using the computer. They are the programs that a regular users sees and manipulates. This includes word processing, spreadsheet, graphic presentations software and others. This Topic discusses some categories of application software, including their strengths that enhance a user's productivity.

OBJECTIVES

After studying this topic, you will be able to:

1. Give examples of application software.
2. Explain the difference between application software and system software.
3. Compare different types application software.
4. Explain the word processing document life cycle.
5. Identify general word processing features.
6. Explain the mail merge process.

7. Explain the types of spreadsheet data.
8. Demonstrate the usefulness of functions and formulas.
9. Describe the features of presentation software.
10. Demonstrate how to produce a simple presentation.
11. Describe the characteristics of statistical software.
12. Demonstrate how to extract results from quantitative data using statistical software.

PERSONAL PRODUCTIVITY APPLICATIONS

Personal productivity applications serve the needs of various users and have several sub-categories. Generally, personal productivity software includes word processing, spreadsheet, presentation, and database programs. Another area, Internet applications, includes Web browsers and electronic mail programs. Multi-media or graphics applications use desktop publishing, as well as editing of photos and graphics, while home and educational applications include personal finance programs, tax preparation programs, reference software and game playing software.

These personal productivity programs are usually stand-alone programs which do not depend on other application software to function. However, there are some applications whose interfaces are the same, and also share data and resources with each other. These applications together are called software suites, and some examples are Microsoft Office - which is the most popular, Corel WordPerfect Office, and Lotus SmartSuite.

Database

Spreadsheet

Table 4.6 Some useful application software

Types	Description
Financial Software	Provides automated assistance for tax preparation and submission. An example is Turbo Tax.
Accounting Software	Provides assistance for personal accounting and cheque writing. Examples are Quicken and QuickBooks
Word Processing Software	Provides assistance in formatting, printing documents. Some examples are Microsoft Word, and Corel WordPerfect
Spreadsheet Software	Provides built-in functions to perform calculations and graphics. Some examples are Microsoft Excel and Lotus

Types	Description
Database Software	Stores, manipulates and retrieves data. Some examples are Microsoft Access, dBase and FoxPro

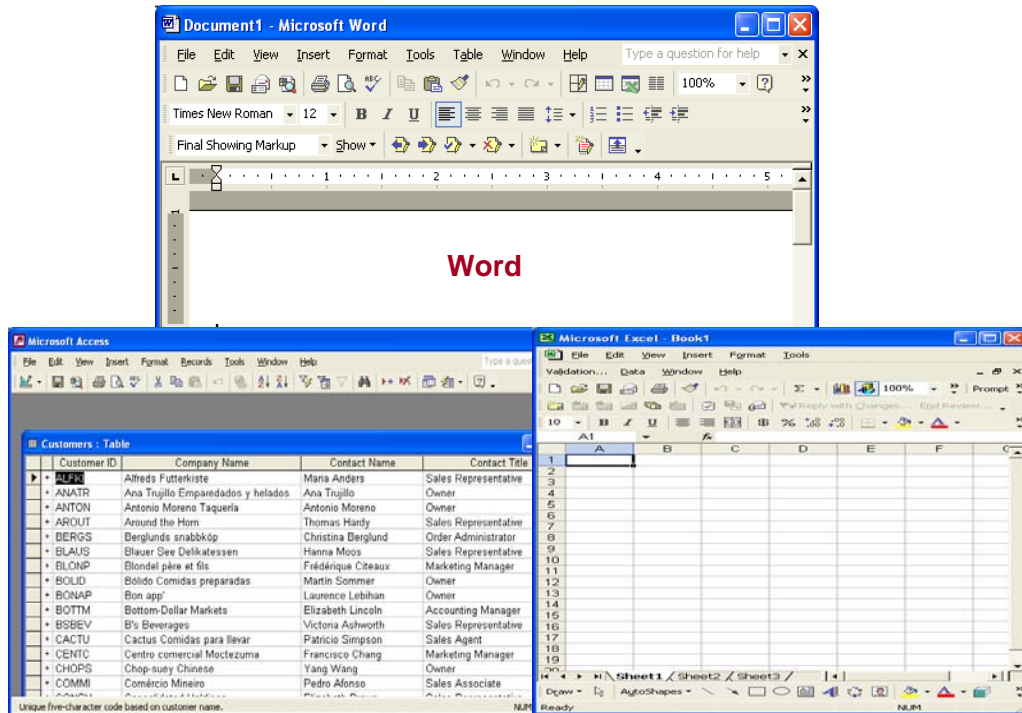

WORD PROCESSING FEATURES

All word processing software is designed based on the document life cycle. The word processing document life cycle, includes creating a document, editing or modifying the document, formatting the document, saving and finally printing to provide a hard copy.

Editing the document allows sections of text to be deleted, moved, or re-typed, and text can also be searched and replaced. Formatting the document enhances its appearance, using various features include using different font types and sizes, line spacing, colours and borders.

Mail merge is one of the powerful features of word processing software. This feature makes it easy to create personalized letters and reports, as well as print addresses on envelopes and mailing labels. With a bit of creative thinking, mail merge can be used to simplify many routine tasks such as personalizing invitations, preparing flyers, making certificates, labeling file folders, and preparing name tags.

Activity 3.4—Open your own word processing software program and investigate the different formatting options it provides. Try and create a document than modify its format using the templates and formatting features.

Hint: Some word processors have extensive help features and/or tutorials. Review some of the tutorials.

WORKGROUP APPLICATIONS

These applications are used by two or more users who work as a team to achieve a common task. The programs therefore should support the sharing of information and sections of the work on a project, scheduling group meetings, group electronic mail services, group decision making and conferencing. Some examples of this software are project management software, groupware like Microsoft Sharepoint and collaborative software like WIKIs (an example of a WIKI is Wikipedia).

ENTERPRISE APPLICATIONS

These applications are used by personnel to support the company in its interaction with customers and employees. Some of the activities include entry of orders, billing, payroll, human resource management, and general reporting activities. Enterprise applications are specialized or tailor made to the specific activities of the company. Examples of enterprise software include PeopleSoft a complete package of company operations and Banner an enterprise system used by universities and colleges to support records management, financial management, course management, student management, etc.

APPLICATION SOFTWARE DEVELOPMENT

Some applications, are developed 'in-house' specifically for use in the company. Other applications are developed via a contract by technology companies that specialize in producing custom application software for their customers. One example of custom software development would be the book ordering process for Amazon.com. Finally, there are off the shelf application software packages which, as the name implies, can be purchased and used without the ability to customize the software.

Activity 3.5 – Consider the different tasks that you can complete with project management software. Also provide the name of one project management application package

Turn to Appendix One for Suggested Response

SPREADSHEET FEATURES

Electronic spreadsheets organize data in a grid of rows and columns. Spreadsheet programs are considered a simple database that can be used to manipulate data in the form of numbers, percentages, etc.

The benefits include the elimination of much of the tedious tasks of performing the calculations manually, so that the calculations are generally error-free. Data is automatically recalculated when one value or calculation is changed. What-if analysis allows users to change one value and have the results instantly recalculated. This is very useful in financial forecasting.

The intersection of a row and column is called a cell. A cell is known by its address which consists of a column letter, followed by row number, for example B7. Cells contain:

- a label, which provides text information or headings of the entries in the spreadsheet,
- a value, which is an actual number that is entered into a cell
- a displayed value which is what is displayed in the cell. This displayed value can

represent:

- a formula—an instruction to the program to calculate a number, such as 10% of a value, or
- a function – a pre-programmed formula, such as SUM to add some numbers

Spreadsheets produce graphs based on the data given in a visual, easily understood format. Analytical graphs are designed to help users analyze and understand specific data using simple line, bar, and pie chart graphs.

Activity 3.6—Open your own spreadsheet software and investigate how spreadsheets can be used to create different types of graphs or chart such as line, bar and pie charts. Try and enter some data and create a graph.

Hint: Some spreadsheet programs have extensive help features and/or tutorials. Review some of the tutorials.

PRESENTATION SOFTWARE FEATURES

The use of pictures, photos and other graphics in a lecture can help the audience remember and understand what is being presented. This is why electronic presentations have become popular in the oral delivery of many topics. Presentation software is also effective for training purposes since video clips can also be included to illustrate certain topics.

Presentation software programs such as Microsoft PowerPoint presents information, usually in point form on many pages called a 'slides'. Presentations can be projected and enlarged using a projector. Indeed the presentation can be published on the Internet as well as printed as outlines or scaled slides on paper.

The usefulness of presentation software includes the easy updating or re-arrangement of the slide content, the inclusion of multi-media to enhance the audience's understanding of the content, the content can be viewed by a larger audience since the presentation can be magnified as necessary, and the presenter can use links within the presentation to link to other documents, files and web resources.

PROPRIETARY VERSUS OPEN SOURCE SOFTWARE

Proprietary software is computer software licensed under exclusive legal right of the copyright holder. The licensee is given the right to use the software under certain conditions, but restricted from other uses, such as modification, further distribution, or reverse engineering. The distributors of this type of software limit the number of computers on which software can be used, and prohibit the user from installing the software on additional computers. Restricted use is sometimes enforced through a technical measure, such as product activation, a product key or serial number, a hardware key, or copy protection.

Public domain software is not subject to copyright and can be used for any purpose. This includes free software, licensed by the owner under more permissive terms and open source software.

Shareware is software that is copyright protected, but may be downloaded and used for free, for a limited time, after which the user is asked to voluntarily send the author/creator a small payment and register the product. Shareware can be downloaded from the internet, but it might also be available on CD.

Freeware is copyrighted software that can be copied, used and distributed at no charge. This software may not be sold or used in any way for commercial purposes. It is mostly downloaded from the internet. Users cannot change this software.

Open Source is software that can be used or modified without restriction, and made available for use without restriction. Open source software is generally available without charge, but can have a small fee and can be downloaded from the internet. This software may not be sold or used in any way for commercial purposes. It is mostly downloaded from the internet.

Takenote: In practice, for software to be distributed as open source software, the human-readable form of the program (the source code) must be made available to the recipient along with a notice granting the above permissions. Such a notice either is a free software license, or a notice that the source code is released into the public domain.

Commercial Software



Open Source Software



TOPIC SUMMARY

You should now be familiar with the relationship of hardware and software. You should now realize how critical each part of a computer system is. As an entrepreneur you must decide the type of hardware and software you will need to ensure your business operates efficiently.

RECOMMENDED UNIT READINGS

After you have completed your review of the topics in this unit it is recommended you read at least one of the following online articles and consider the related reflective questions as you read the materials.

Microsoft Corporation. (2006). Windows History. Available at:

<http://www.microsoft.com/windows/WinHistoryDesktop.mspx>.

This Microsoft article describes the evolution of their Windows Operating System. As you read it consider the following question:

How has the creation of the Windows operating system impacted the use and evolution of the computer?

McLean, P. (2007). Road to MAC OS X: Safari 3.0. Appleinsider. Available at:

http://www.appleinsider.com/articles/07/10/18/road_to_mac_os_x_leopard_safari_3_0.html?page=1

This article explores the evolution of the web browser from the perspective of Apple's Safari. But it does explore the evolution of other web browsers including Windows Explorer and Firefox. As you read the article consider the following question:

What impact has the invention of the web browser had on our social, economic cultural and education systems?

Reimer, J. (2005). A History of the GUI. Ars Technia. Available at:

<http://arstechnica.com/articles/paedia/gui.ars/1>.

The author of this article explores the evolution of the graphical user interface. As you read the article consider the following question:

How has the invention of the graphical user interface impacted how the computer has been used? What is the next step in GUI development?

UNIT – SUMMARY

The major systems software concepts discussed in this unit were:

- System software monitors the activities of the computer so that it functions efficiently.
- The operating system comprises a set of programs that work with the peripheral devices and computer hardware to control and organize the general operating functions of the computer.
- Operating systems differ in functionality, flexibility and ease of use.
- A platform of a computer system is the underlying hardware and software that it allows it to function.
- The functions of the user interface are to start application programs, manage secondary storage, such as hard disks, as well as manipulate files and folders, and finally shut down the computer safely.
- The Graphical User Interface (GUI) uses graphics or icons which represent various tasks.
- The command-line interface requires the user to type keywords or commands at a prompt, in order to enter data or execute commands.
- Utility programs are tools that help the operating system manage the computer system's secondary or non-priority jobs.
- Language translators are these systems programs convert the data in a program (source code) into machine language code (object code) that the computer can then process.
- Windows Explorer is a tool for organizing files on disk and uses several important components to manage drives such as disks (floppy disks, CDs, DVDs, and memory sticks), folders and files.
- Files are a collection of information, data, or program files.
- Folders are used to organize where the files are located, so that a particular folder may contain all spreadsheet files, while another folder can contain all word processing files.
- A disk is a secondary storage device such as a floppy disk, CD, DVD, or memory stick, where folders and files can be stored.

- The root folder is the main or general folder found on all disks.
- Folders created within the root folder, are called subfolders.
- Deleting folders also removes files and any subfolders in that folder.

The application software concepts discussed in this unit were:

- Application software is what users require to complete their tasks, while system software is the software that interfaces between the hardware to perform what is required by the application software.
- Personal productivity software programs are usually stand-alone programs which do not depend on other application software to function.
- The word processing document life cycle, includes creating a document, editing or modifying the document, formatting the document, saving and finally printing to provide a hard copy.
- Mail merge is one of the powerful features of word processing software which makes it easy to create personalized letters and reports.
- Workgroup applications are used by two or more users who work as a team to achieve a common task.
- Enterprise applications used by personnel to support the company in its interaction with customers and employees, such as entry of orders, billing, or payroll.
- Electronic spreadsheets organize eliminate much of the tedious tasks of performing numerical calculations manually.
- Spreadsheets produce graphs based on the data given in a visual, easily understood format.
- The usefulness of presentation software includes the easy updating or re-arrangement of the slide content, and the inclusion of multi-media to enhance the audience's understanding of the content.
- SPSS (Statistical Package for the Social Sciences) is a software application that manages data in a systematic way in order to perform statistical analysis on a set of data.

System software plays an important role in the proper functioning of a computer system. This unit explained the three main programs that comprise system software, namely operating systems, utility programs and language translators. Of course different types of system software are necessary for the different types of operating systems available. The

user interface was also discussed as a mediator between the user and the computer system, to ensure that the computer system performs certain complex or other mundane tasks for the user.

This unit also introduced personal productivity software or applications software which are stand-alone programs that do not depend on other applications to function. Some popular application software programs discussed were for word processing, spreadsheet analysis, presentations, and statistical analysis. Some other applications such as workgroup and enterprise applications were also introduced, since they are also widely used in the day-to-day tasks in many businesses.

Unit 9: File and Data Management

9

INTRODUCTION

This unit explains how a computer file and data management system operates and is accompanied by some practical activities which are useful in helping understand how files can be organized on secondary storage devices into multiple folders and sub-folders.

UNIT OBJECTIVES

At the end of this unit, you should be able to:

1. Illustrate the movement of files, folders to organize information in a meaningful way.
2. Explain different disk and file management operations.

This unit consists of one Topic which describes disk and file management operations and then is supported by some practical exercises that students are encouraged to complete.

TOPIC 1 - DISK AND FILE MANAGEMENT OPERATIONS

INTRODUCTION

This Topic uses Microsoft Windows Explorer as a tool for organizing files with data and information into manageable areas called folders.

OBJECTIVES

After studying this topic, you will be able to:

1. Describe a computer the operation of a computer file management system.
2. Show diagrammatically basic file and data management structures.
3. Carry out basic file and data management operations.

FILE MANAGEMENT

In Microsoft Windows operating system, Windows Explorer is a tool for organizing files on disk and uses several important components to manage drives such as disks (floppy disks, CDs, DVDs, and memory sticks), folders and files. When Explorer is started, you will see the directory window, which displays the contents of a specified folder on a selected drive.

Files, folders and disks must interact to organize information in a meaningful way.

Files are a collection of information, data, or program files. For example, an application software program such as a spreadsheet or word processor is a program file, while the document created using the spreadsheet or word processor is called a data file.

Folders are used to organize where the files are located, so that a particular folder may contain all spreadsheet files, while another folder can contain all word processing files.

A disk is a secondary storage device such as a floppy disk, CD, DVD, or memory stick, where folders and files can be stored. Consider a disk to be like a filing cabinet with the folders similar to physical folders or drawers in the filing cabinet. These folders can therefore contain files or rather paper files! So you can have many folders in a file, and the folders can contain many files! Also, just as your filing cabinet can become full of files, your disk (storage device) can also become full.

ROOT FOLDERS AND SUBFOLDERS

Two terms need to be explained before beginning the practical Topic. A root folder is the main or general folder found on all disks and is identified with the disk drive letter followed by a backslash (\). A root folder is often known as a drive or storage device. Table 4.2 illustrates some other designated disk drive letters. So the root directory of the floppy drive is designated A:\

Table4.2 Designated Drive Letters

Disk Drive Name	Designated Drive Letter
Floppy Drive	A:\
Another Floppy drive	B:\
Hard Disk Drive	C:\
Another Hard Disk Drive	Can be given another letter such as D:\ or more depending on the number of installed hard-drives on the computer.
Memory Stick (also called Flash drive)	If there are two hard drives on the computer, then it is designated E:\
Another Memory Stick	F:\ - Assuming you have a second one.
A Network Drive	H:\ or higher - Note network drives do not physically reside on your desktop or laptop computer. To connect to a Network Drive your computer must be installed on a local or wide area network.

Once you create folders within the root folder, then these folders are called subfolders. So if the root folder contains another folder called WORD, then the folder is identified by its name preceded by the name of the root. Therefore we have in our example, A:\WORD which indicates that the subfolder WORD is in the root folder of the A: drive. Folders can have more folders within them. So if ASSIGN1, is created within the WORD Subfolder, then A:\WORD\ASSIGN1 indicates that the ASSIGN1 subfolder is within the WORD subfolder contained in the root folder of the floppy disk. Another way to describe the hierarchical nature of the above example is below:

- Root Folder (e.g. C:\)
 - Sub Folder (e.g. C:\WORD)
 - Sub-Sub Folder (c:\WORD\ASSIGN1)

Activity 4.1 - Using the Directory Window

Launch Windows Explorer by right-clicking the Start button and selecting Explore. Then maximize the resulting window.

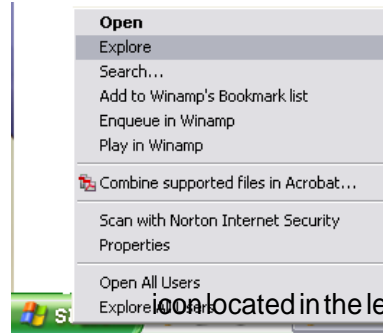

Double-click on the Start button located in the left panel. (you may not see the numbers before the C: A list of folders will be displayed in the right panel. Double-click the WINNT or WINDOWS folder, depending on the system you are using. (You may get a message telling you that these files are hidden for security reasons. Simply click the Show Files option.) You can also double-click on any folder for this activity; the Explorer title will be updated to reflect the name of the folder that you have opened.

Double-click the Desktop folder in the left panel, or in the file list (in the right panel), and notice the files change to reflect those in the desktop folder.

You should now select and click the View pull-down menu, and notice how the Explorer panels change with each option. Try the four options in the Arrange Icon option and Details option to see the result.

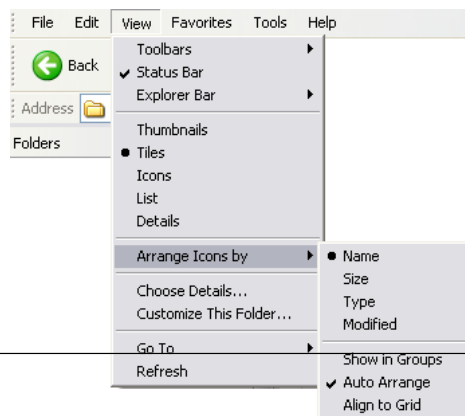

CREATING AND DELETING FOLDERS

You can also create and delete folders in Explorer. To create a new folder, you first need to know *WHERE* your folder will be located, such as the desired drive, and then the directory from the tree (left panel). Select the disk and folder that you want to create this new subfolder within, and select File New Folder from the menu bar.

You need to be careful when deleting or removing folders, since you may remove a folder with important files still within it. Deleting folders also removes files and any subfolders in that folder. Click to select the folder, and then select File Delete from the menu bar.

Activity 4.2 - Creating and deleting folders

Launch Explorer and put your floppy disk in the floppy drive. Click on the Floppy Drive icon.

Select File New Folder. Alternatively you can right click in the right pane and select the New Folder Option

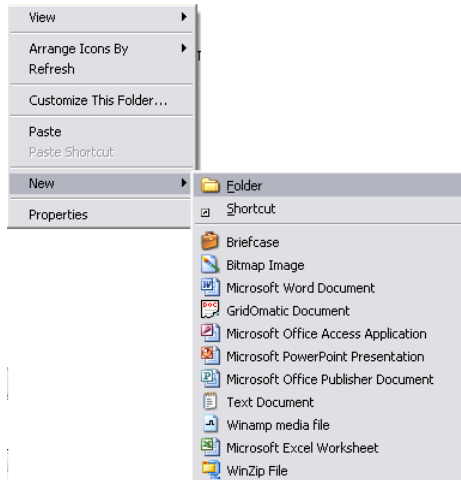

Type DISTANCE and press [ENTER]. The new folder has been added under the A:\ root directory. Double-click the folder DISTANCE and select File New Folder (or once again right click and select New Folder). Type ACTIVITY. Your directory tree for the floppy disk is shown:

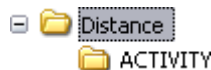

If you have other folders, then they will also be shown.

Click on the DISTANCE folder. To delete this folder (and all its contents), select File Delete from the menu, or press DELETE. Click OK when the Confirm Delete dialog box appears.

DISK AND FILE MANAGEMENT OPERATIONS

Windows Explorer allows the management of files such a wide range of file activities including copying, moving, deleting and renaming.

Copying Operation- In order to copy one or more files from one folder to another, these file(s) should be first selected from the directory list. Multiple files can be selected from the folder by clicking on the first file (remember, do NOT double click as this will open the document and not select it), then hold down the CONTROL key while clicking on each individual file. If the files are located together, then first hold down the SHIFT key and then click on the first and then the last file. All files between the first and last will be selected. A file can be de-selected by clicking on the file a second time. After selecting the file(s) use the Edit Copy command, or hold down the CTRL key and tap the letter C on the keyboard. Click in the destination folder on the desired drive, and select Edit Paste. Your files should be copied to the desired folder.

Moving Operation - To move one or more files, first select the required files, as in the copying operation above. With the files selected or highlighted, click and hold on the selected files. Then drag the mouse pointer onto the destination folder name in the tree and release the mouse button. You should check to see that the files were actually moved to the desired location. Alternatively, files can be moved by first selecting the files and using Edit Cut, to remove the files from the first location. Then click in the destination folder on the desired drive, and select Edit Paste to move the files to this folder.

Renaming Operation- Renaming files is accomplished by selecting the desired file and then choosing File Rename from the menu. Simply type in the new file name and press Enter.

Activity 4.3 - Disk and File Management Operations

First create the following tree structure on your floppy disk, or memory stick (removable disk)

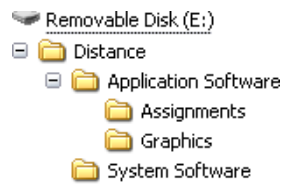

Use Start, Programs, Accessories, and Paint to create the four bitmap files and save those files with a Monochrome Bitmap file format. Use WordPad or Notepad to create and save the four text files shown. You do not need to type anything in the file. Save these files in the root folder of your disk. Also make sure your files are arranged by type in Explorer.

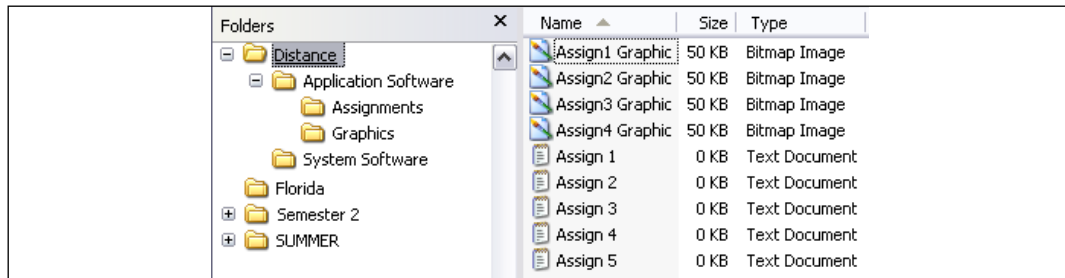

Copy all bitmap files from the root (Distance) to the Graphics folder. To do this:

Click on the first file Assign1 Graphic, hold the SHIFT key down and click or select the Assign4 Graphic to select all of the graphic files.

Select Edit Copy from the menu, or hold down the CTRL key and tap the C key. Click on the Graphics folder in the directory structure (left panel). Select Edit Paste, or CTRL V to copy the files. A dialog box will show you the files as they are copied.

Move the text files to the folder Assignments.

Click on the first file Assign1, hold the SHIFT key down and click or select the Assign5 text file to select all of the text files.

Select Edit Cut from the menu, or hold down the CTRL key and tap the C key. Click on the Assignments folder in the directory structure (left panel). Select Edit Paste, or CTRL V to copy the files. A dialog box will show you the files as they are copied.

Delete the remaining files from the root. Select *all files in the root* and tap the DELETE (DEL) key. Select YES when the Confirm Multiple File Deleted dialog box appears.

Rename files. Click on the System Software folder in the Tree. Select File Rename from the menu, and type in the new file name: Operating Systems. Press ENTER.

Click on the Application Software folder and press DELETE. What happens? Since you do not actually want to delete this folder, what should you do?

TOPIC SUMMARY

In this topic we explored how to create a file and data management system that will ensure you are able to effectively store and retrieve information from your computer system. An effective business will treat its data like gold. You must know how to protect, how to store it and how to back it up.

RECOMMENDED UNIT READINGS

After you have completed your review of the topic and its related activities, you should review the resources available at the site described below. As you are reviewing the information in the University consider the related reflective questions as you read the materials.

University of Virginia. (2007). Resources: File Management. Information Technology Centre. Available at: <http://itc.virginia.edu/desktop/docs/fms/>.

Instructions: As minimum review the two tutorials (Windows File Management and Macintosh File Management) and the Best Practices in File Management PowerPoint slideshow. Consider the following question:

How can I use the best practices and tips and tricks presented in the tutorials and slideshow to better manage the files and data on my own computer?

UNIT 4 -SUMMARY

The following concepts were explored in this unit:

1. Windows Explorer is a tool for organizing files on disk.
2. Files are a collection of information, data, or program files.
3. Folders are used to organize where the files are located.
4. A disk is a secondary storage device such as a floppy disk, CD, DVD, or memory stick, where folders and files can be stored.
5. The root folder is the main or general folder found on all disks.
6. Once you create folders within the root folder, then these folders are called subfolders.
7. To create a new folder, you first need to know *WHERE* your folder will be located.
8. You need to be careful when deleting or removing folders, since you may remove a folder with important files still within it.

This unit explained the difference among terms such as disks, files, folders and sub folders and root folder. It also noted the various disk drive letter designations when performing data and file management tasks.

Unit 10: Input Devices

INTRODUCTION

This unit builds upon earlier descriptions of computer hardware and provides detailed descriptions of the devices needed by systems users to input information and how to view the output of processed data and applications programs.

As noted earlier hardware input devices are integral in processing data into meaningful information. Different hardware devices enable data to be input in a form that the computer can process and translate into an understandable form for humans to interpret.

Output devices are peripheral devices that enable us to view, hear or store the result of the computer's processed data. Note that output of processed data is different from storing the processed data before it is output. Storage of data and the associated storage devices are discussed in Topic 5 of this unit, however in this Topic, we describe the need for output devices and explain why some output devices are more suited for certain applications than others.

UNIT OBJECTIVES

At the end of this unit, you should be able to:

1. Describe the various types of manual input devices.
2. Describe the various types of direct input devices.
3. Distinguish between the types of output devices.
4. Describe the types of terminals.
5. Describe different storage devices.

This unit is divided into four topics:

- | | |
|----------|--------------------------------------|
| Topic 1: | Keyboard and Pointing Input Devices. |
| Topic 2: | Direct Input Devices. |
| Topic 3: | Softcopy Output Devices. |
| Topic 4: | Hardcopy Output Devices. |
| Topic 5: | Storage Devices. |

TOPIC 1 - KEYBOARD AND POINTING INPUT DEVICES

INTRODUCTION

Computers need raw data to process into meaningful information. This Topic introduces devices used for getting raw data into the computer. Some software applications require different devices with certain characteristics for data entry. These will also be discussed in this Topic.

OBJECTIVES

After studying this topic, you will be able to:

1. Describe the purpose of an input device.
2. Give examples and characteristics of direct input devices.
3. Match an input device with the most appropriate situation.
4. List the types of keyboards.
5. List the pointing devices and the advantages and disadvantages of each.

DATA INPUT

Before we can use the computer for various tasks, including surfing the Internet or as part of our daily work, computer systems need to convert data into meaningful information or representations that are familiar to the user. Data can be obtained in various forms for input into the computer. Actions by computer users are the most common way of inputting data. Other ways input data into a computer for processing is through the transfer of data (or files) from other storage devices (such as a hard-drive, memory stick or CDROM) and transfer of data from another network computer.

Data is input from different devices in the following forms:

- Raw data, such as words, numbers, pictures, symbols, graphics, or sound which needs to be processed into meaningful data.
- Software programs that give the computer its instructions and therefore need to be transferred from an external storage device to the computer's internal memory.
- Commands that instruct the computer to do a specific task. Examples include special keywords or typed commands that are either entered from a keyboard, or a left click from a mouse, or even a touch on a screen using a pointing device.
- Responses or prompts either through sound or visual boxes requiring the user to usually provide some typed response, reply or feedback, such as OK, Cancel, Yes or No.

Activity 5.1 – Consider the following questions.

1. Explain what is meant by a user.
2. List two ways in which data can be inputted into the computer.
3. Give two examples of the type of data that can be input into a computer.

Turn to Appendix One for Suggested Response

Hardware devices are used to translate data into a form that the computer can process can be placed in three general categories: Keyboard, Pointing and Source Data Entry. The devices in these categories used to get this data input to the computer are described below.

THE KEYBOARD

A computer keyboard is the most common method of inputting data into a computer's memory directly. The keyboard is an improvement on the typewriter and comprises keys of letters, numbers, some punctuation marks and other symbols as well as some pre-defined keys called function keys. The user can type words and other commands which are converted into electrical signals (ones and zeros) and input into a computer's memory.



Keyboards are either connected to the computer by a cable or by a wireless transmitter/receiver. Cordless keyboards use infrared beams and low frequency signals to transmit their data from the keyboard to the computer. Wireless keyboards that use infrared beams to transmit data require a clear line of sight between the device and the infrared port on the computer. Wireless keyboards that use low frequency signals to transfer data need to be in close proximity to the computer and may experience interference from other wireless or electrical devices.

Keyboards are reproduced in various shapes and sizes to suit users' specific needs. Today keyboards that are ergonomically designed are popular to prevent injuries such as carpal tunnel syndrome or other repetitive hand and wrist injuries. Keyboards have also been created to support individuals with different physical disabilities. These include Braille keyboards for those that are blind, one handed keyboards for those users who can only use one hand, keyboards for special purpose devices (such as a Personal Digital Assistant or cell phone) and digitally projected keyboards that allow a keyboard to be displayed in a variety of locations.

POINTING DEVICES

Pointing devices are used to move a cursor on the monitor corresponding to the movement of the pointing device. The computer mouse is the most widely used pointing device. It fits snugly inside the palm of your hand, and allows the user to send commands to the computer. As you move the pointing device to the left, its movement is mirrored on the monitor display in the same direction, with a corresponding pointer (□) on the screen.

A mouse can provide input in a number of different ways. Specific actions that are included in all mouse pointing devices include:

- A single-click of the left or right mouse button is used for selecting an item or option on the screen.
- Double-clicking opens a program or special screen called a dialog box.
- Click and drag involves holding down the left mouse button while dragging or sliding the mouse. This allows the user to drag, move and reposition items/information anywhere on the screen.









A recent addition to the design of the mouse is a rotating wheel which, when scrolled up or down, correspondingly scrolls the page up or down with a text document. The cordless mouse gives added flexibility to the user, by removing the connection of the cord to the computer; however the mouse must remain in sight of a receiver to work.

The mouse allows the user to quickly move the cursor on the screen instead of typing commands on the keyboard to move data around the screen. However the use of the mouse requires constant hand and wrist movement and like the keyboard may result in wrist injuries.

There are a number of other pointing devices that have evolved since the mouse was invented. Many of them have capabilities that are similar to the mouse. These specialized pointing devices add additional features that support customized software applications that can react based on the input devices. Some of the more common pointing devices are described in table 5.1.

Table 5.1 – Common Pointing Devices

Pointing Device	Description	Advantage	Disadvantage
 <p>Trackball and track point</p>	<p>Some look like an inverted mouse with the ball on the top or side of the trackball for the user to roll. The track point is more commonly found embedded in the keyboard of laptops</p>	<p>Uses less space for movement than a mouse would, and so is not as tiring as using the mouse.</p>	<p>Again requires much ball control using a finger or thumb. Also using same wrist muscles is tiring and can also cause injuries.</p>
 <p>Touch Screen</p>	<p>The user makes selection by just touching the screen</p>	<p>The natural tendency to touch an object is a distinct advantage of the touch screen.</p>	<p>Reaching out to touch the areas on the screen can become tiring if there are many choices to be made. The screen must also be large enough to accommodate these several choices since fingers pads are bigger than the thin cursors.</p>
 <p>Pen Input</p>	<p>Used generally in Personal Digital Assistants (PDA) or Tablet PCs. Functions like a mouse with clicking replaced by tapping the screen.</p>	<p>Apart from its small size, it can imitate handwriting instead of typing using keyboard.</p>	<p>Device must be trained to recognize user's handwriting. Also the user can lose the pen since it is not usually attached to the device</p>

Pointing Device	Description	Advantage	Disadvantage
Touch Pad 	Uses a touch sensitive pad for controlling the cursor. Cursor follows sliding finger movement across the pad. Buttons allow for clicking, or tap on the pad with a finger.	Similar to the touch screen	The constraints of the size of the touch pad can be restrictive, and constant reaching for the touch pad can also be tiring
Game Devices: Joy stick  Game Console 	Cursor motion controlled either by a stick for the joystick or arrow buttons for the game pad.	Gives a more natural-feeling control for motion in flying or driving games	More expensive and much bigger than other devices.

Activity 5.2 – Consider the following questions:

1. Explain one common problem that can result from constant use of pointing devices
2. Can you identify those persons who will not be able to use pointing devices?

Turn to Appendix One for Suggested Response

TOPIC SUMMARY

In earlier units we explained how important data was and how it was managed internally by a computer system. During this topic discussion you reviewed a number of different ways of getting raw data into a computer and how to get processed data out of your computer. In the next topic you explore some more exotic means of data entry and retrieval.

TOPIC 2 - DATA ENTRY AT THE SOURCE

INTRODUCTION

As the term implies, these devices enable the data to be entered or captured from its origin or source with minimal or no interference from the user. The advantages for this method are to eliminate extra handling and save time in the user entering the data, thus lowering labour cost, and reducing errors.

OBJECTIVES

After studying this topic, you will be able to:

1. Describe a source data entry device.
2. Explain biometrics.
3. List the various input devices.

SOURCE DATA ENTRY

Source data entry minimizes any mistakes that may occur during data input, and avoids having to re-enter the data. Data is feed directly from a storage device, application program or via a networked device that is attached to the computer. Some examples of devices that use source data entry methods are: an air conditioning unit that monitors the temperature of a room; a device that maintains a consistent environment in an incubator; an altimeter in an airplane; automated downloads for different application programs; devices that are used in a controlled environment o maintain the humidity, or devices that test the water in a pond for acidity or alkalinity.

Activity 5.3 - A weather station uses SENSORS to take various readings or measurements which are stored or logged for later use.





1. State the general name for the type of input that is required to take these readings.
2. State are the advantages of using these devices to log the data compared to a human being taking the measurements.
3. Explain the kinds of readings that could be taken by the weather station.

Turn to Appendix One for Suggested Response

BIOMETRICS

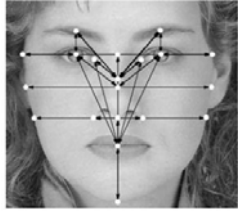
Biometrics is a human-biology input device, which uses a user's body characteristics as input to a computer system. These characteristics include fingerprints, face structure and hands to the patterns in the eye's iris.

The federal government has made biometrics part of its post-Sept. 11 security measures. Since October 2004, the USA Department of Homeland Security has been gathering and comparing biometric data on all foreign travelers to the country against database records of criminals and terror suspects. Thus travelers are required to provide two digital index finger images and have a passport with a digital photograph in order to gain entry to the country. To date, the following biometric devices have been used to capture the following physical characteristics to verify a user's identity:

Physical Characteristics	Illustration	Description
Facial Recognition Systems		Measures factors such as the distance between facial features (pupil to pupil, for example) or the dimensions of such features (such as the width of the mouth)
Finger Scans		Measures characteristics such as changes in the individual lines of the finger pad
Hand Geometry Scans		Measures factors such as the size of the palm and the length and width of the fingers
Retina Scanning		Uses a beam of light to scan the pattern of veins in the eye's retina
Voice Recognition Systems		Analyze the human voice through computerized pattern-matching programs

SCANNERS

The scanner is like a photocopying machine. A document is placed on a glass plate and a light emitting diode is passed over the document and the content of the document is converted to a digital image. Scanning software allows the users to take the captured digital image and convert it to a graphic image or a text based document that can be edited using a typical word processing program. The software that is used to convert a scanned image to a text document is known as Optical Character Recognition software. Most scanners are packaged with OCR software. An example of OCR software is [OmniPage](#).

Check it out.

The majority of scanners are large enough to scan full sheets or entire pages of books. Others are small enough to scan a row of numbers of a product. These smaller devices are known as hand scanners or portable scanners. Today many multi-purpose printers include the ability to scan documents, print documents and fax documents all using the same printer.



BARCODE READER

Barcodes are different groups of vertical bars that represent specific types of data that can be read by a barcode reader. A barcode reader is a specialized type of scanner that captures the bar code and passes the data to a specialized application or data base for interpretation and output to a specific hardware device. Businesses such as supermarkets and clothing stores now use printed bar codes on products and letters to track inventory and calculate the sale at the checkout counter. Post offices and courier services use bar code readers and forms with bar codes to track and sort mail and packages.



Barcodes make it easier for a business to track their inventory and maintain their stock balances in a way that supports just in time sales and distribution. Barcodes generally contains product details such as product name, size, manufacturer, country of origin. They can be customized to show location, time in, time out, etc. As each product barcode is scanned, the symbols in the bar code are translated or converted into digital code. At the same time, the stock value is automatically reduced by one.

MAGNETIC INK CHARACTER RECOGNITION (MICR)

The 'computerized looking' numbers printed at the bottom of your bank cheques are made of a special magnetic ink so that can still be scanned even if the cheque has been folded or has dirty marks on it. These numbers represent the account number, bank sort codes as the amount on the cheque, which banks use a special

Magnetic ink character reader (MICR) to scan the numbers for input.

Bank on which Check is Drawn	Customer's Account Number	Check Number	Amount of Check
------------------------------	---------------------------	--------------	-----------------

MAGNETIC STRIP READER

Many credit cards, debit cards and other loyalty plastic cards have magnetic strips on the back of the card. The strip contains some of the cardowner's personal information.

When the user inserts the card into the magnetic strip reader, and inputs their Personal Identification Number (PIN), the data stored on the strip is scanned and transferred to the computer system for further processing according to the user's request.



OPTICAL MARK READER

An optical mark reader scans pre-printed forms, such as lottery tickets. In education, universities, colleges and some secondary schools use pre-printed forms for their examinations. The forms act as the answer sheet for multiple choice questions in the examination booklet. Learners enter their proposed answer on the pre-printed answer sheet using a pencil. When put through a scanner with appropriate software the pencil marks to digital form and the digital input is compared to an electronic answer key that automatically marks the examination and puts data in the student information system reflecting the results for each student.



Activity 5.4 - Choose the most appropriate response for each of the following questions on input devices

The most suitable input device for creating a short report would be a:

1. Mouse
2. Scanner
3. Keyboard
4. Joystick

The most suitable input device for selecting (highlighting) text on a screen would be a:

1. Joystick
2. Mouse
3. Keyboard
4. Touch Screen

In order to create a digital image from a paper photograph you would first need to input it using a:

1. Scanner
2. Joystick
3. Digital Camera
4. Touch Screen

Magnetic Ink Character Recognition is often used on:

1. Receipts
2. Photographs
3. Cheques
4. Barcodes

Multiple choice answers on a test paper can be input using:

1. Barcode Reader
2. Optical Mark Reader
3. Magnetic Ink Character Recognition
4. Magnetic Strip Reader

Turn to Appendix One for Suggested Response

A variety of other miscellaneous input devices are now in use to capture just about any form of input available. Let us examine a few of these input devices.

AUDIO INPUT

A very useful device for enabling audio input into computers is a microphone and speech recognition software. This type of input enables the computer to recognize words spoken into a microphone through the use of special software. The words are inserted into a word processing document. Recent technology is perfecting continuous speech recognition where the user does not have to pause between words. A popular speech recognition package is [Dragon Naturally Speaking](#).

Voice recognition software is also used by the disabled to input commands to voice enabled application software. For example The Windows 7 operating system has the capability to control all menus via voice input. If you have a Window based computer check out the “Speech Recognition” icon located in the “Control Panel”.

Today many vehicles employ voice recognition systems to input hands free commands to the driver’s GPS, cell phone, radio, iPod and to control the car’s internal systems.



DIGITAL INPUT

Digital cameras are quickly replacing film cameras. Instead of waiting for the film to be developed, pictures can be taken and re-taken, previewed before they are stored. You can choose to print what pictures you wish to print, you can delete unwanted pictures and with the add of photo editing software, you can change the look of your pictures. The images are transferred to a computer using special software and a USB

cable or digital flash card (called an SD card). The printed picture depends on both the quality of the paper and printer. Or you can choose to email your pictures to photo production companies that will print the selected photos and return them to you.

If you want to capture motion than there are two different technologies. Digital Video cameras use a special technology to record video images while a Web Cam, a tiny video camera can be attached to the computer to feed pictures directly to the computer. Webcams are popular for video conferencing over the Internet, as well as documenting just about anything such as weather or traffic flows. Digital video cameras provide better quality movie output and is easier to use when moving from place to place to capture your pictures.



Today’s smart cell phones have both a digital video and still camera capabilities. Transfer of photos or videos can be easily accomplished using a digital SD card or by attaching the phone to a computer using a USB connection.

Digital piano keyboards and other digital instruments can input music to your computer. The output of what the musician plays is captured by the computer so that the artist can play it back later or modify and enhance it using media production software.

TOPIC SUMMARY

Many of the input devices explored in this topic discussion are used by many retail and information processing businesses. You must consider the different methods of data input and the types of input devices you will need to support your business environment.

Unit 11: Output Devices and Storage Devices

11

TOPIC 1 - SOFTCOPY OUTPUT DEVICES

INTRODUCTION

There are two different types of computer output called: softcopy and hardcopy output. Softcopy output is intangible. It is not a physical object like a print-out. Softcopy out can only be heard or seen through different output devices. In this section we will discuss the different softcopy out devices.

OBJECTIVES

After studying this topic, you will be able to:

1. Describe the purpose of a softcopy output device.
2. Give examples and characteristics of visual output devices.
3. Give examples and characteristics of audio output devices.
4. Match an output device with the most appropriate scenario.
5. Explain what a terminal is and list the different types of terminals.

SOFTCOPY OUTPUT TYPES

Softcopy output can be further sub-divided into visual output and audio output.

Softcopy - Visual Output

Visual output of text, graphics, or video is usually displayed on a monitor. A monitor is another peripheral device which uses a video card connected to the computer, to display output on the screen. The video card is the device that interprets the digital content and turns them into picture elements called pixels. Pixels allow an image to be displayed on visual devices through a number of individual dots on the screen that create a visual image.

The resolution is the number of pixels (individual dots) measured as *horizontal pixel number x vertical pixel number*. So a 640 x 480 resolution means that the screen is 640 pixels wide by 480 tall. That means a monitor with this resolution can display 307,200 pixels or individual dots on screen. The more pixels on screen the greater the clarity and contrast of the visual output. For example a resolution of 800x600 displays 480,000 pixels or over 50% more pixels than the lower 640 x 480 resolution and thus provides a better picture.



The level of resolution depends on two hardware components: the monitor and the video card. Monitors are made to support different video resolutions and video cards are made

to output a maximum number of pixels. Even if you have a monitor that can output 1024x768 resolution, the video card must also support this level of resolution. The maximum visual output is based on the capabilities of the lower quality piece of hardware, so make sure these two pieces are equal in resolution output.

Monitors are made in various sizes, and these sizes are measured diagonally from one corner to the opposite corner in inches (e.g. from bottom right corner to top left corner reflects the size of the monitor). Therefore the size of a monitor includes the case around the viewing area of the screen. Common monitor sizes range from 15 to and 21 inches.

Although monitors come in various sizes, the quality of the output on the screen is also important. The resolution and refresh rate also determine the quality of the monitor display. We have discussed resolution, now let's look at refresh rate.

Refresh rate is the number of times per second the pixels are recharged, so that the image on the screen remains consistent, and not flicker. The faster the refresh rate the better the picture. Refresh rates are measured in hertz (HZ) and based on how fast the horizontal and vertical resolution is completed. A typical refresh rate is 70 to 90 HZ. The higher the number the better. Like resolution, refresh rates are tied to the capabilities of both the monitor and the video card. Video cards can only refresh the screen as fast as the monitor will allow it.

Activity 5.5 - Briefly explain why a user would need a smaller or even a larger monitor size, than a standard 15 or 17 inch monitor.

[Turn to Appendix One for Suggested Response](#)

Today there are two types of monitor technology. The older cathode ray (CRT) monitor looks very much like an older CRT television. It uses old technology and is slowly being replaced by Liquid Crystal Display (LCD) monitors which use digital input vice analogue input. The LCD monitors will soon replace the CRT monitors because:

- Higher quality output on LCD monitors.
- LCD monitors are lighter and take up less space on the desk.
- LCD monitors use less energy.
- LCD monitors create less heat.

The one advantage of CRT monitors is that they are cheaper than LCD monitors.

LCD monitors come in a variety of types and sizes that include: passive (monochrome or one colour), active, gas plasma, and field emission display screens, which are all beyond the scope of this course.

Activity 5.6 - Explain whether a CRT monitor would be a good choice for a portable computer display.

Turn to Appendix One for Suggested Response

Activity 5.7 - You are a student who has saved some money to purchase a second hand computer to produce your assignments, and to access your course work on the Internet. Explain, with valid reasons what type of monitor you would purchase.

Turn to Appendix One for Suggested Response

Softcopy - Audio Output

Audio output enables the computer to output sound using two components of the computer system. The first component is a sound card, which is a separate card or board installed on the computer system unit. A sound card is necessary to listen to a sound file, play a recording or receive audio feedback from the operating system or other application programs.

Audio output also requires speakers or head phones to be connected to the sound card so that you can hear the audio output. In laptops, speakers are embedded in the computer unit. In PCs and some MACs you need external speakers that can be attached to the computer's audio card.



Audio quality is dependent very much on the quality of the sound card and the quality of the speakers. Today high quality sound cards can produce Dolby Digital sound and surround sound experiences. You can also purchase surround speakers with sub-woofers that sound as good as any stereo system. It all depends on how much money you want to spend.

TOPIC SUMMARY

Often data is in the form of audio or highly detailed graphics, animations or video. If your business requires audio, animation or detailed graphics output you need to consider using a computer system with an appropriate audio or video card. In the next topic we will discuss output devices like printers and other hard copy outputs.

TOPIC 2 - HARDCOPY OUTPUT DEVICES

INTRODUCTION

A printer is yet another peripheral device. However this device produces a physical copy or hard copy of the computer's output as opposed to the temporary or softcopy output displayed on a monitor or through a speaker.

OBJECTIVES

After studying this topic, you will be able to:





1. Match printer requirements with the most appropriate situation.
2. Explain what a terminal is and list the different types of terminals.

HARDCOPY OUTPUT – AN OVERVIEW

Printers output documents in the form of characters, text or graphics, and the output quality is measured in dots per inch (dpi). The more dpi on single page the higher the quality of the printout. A typical printer today prints at 600 dpi and a photo quality printer prints at 1200 dpi or higher.

There are two general types of printers: impact and non-impact.

- Impact printers strike a special hammer or wheel with the letter or character against ribbon that has ink on it, thus leaving an image of the letter on the paper. Examples include the dot-matrix printer.
- A non-impact printer produces the characters and images without having to hit the paper. These printers use either jets to spray the ink on the paper or lasers to burn the ink onto the paper. Since there is no hammering against the paper, these printers cannot print copies of the document using carbon paper. Examples include laser, inkjet, plotters and multi-function printers.

Printer Type	Impact Printer	Non-Impact Printers		Plotter
Example	Dot-matrix printer	Ink jet printer (or Bubble-Jet)	Laser printer	Plotter
Picture				
Description	Hits the character on a ribbon against paper. Is especially useful for multi-part (carbon copy forms) when duplicate copies are needed	Makes characters by spraying dots of ink onto paper	Laser printer works like a copier	Uses a pen that moves over a large revolving sheet of paper. It is used in engineering, drafting, map making, and seismology.
Quality of printout	The more pins, the smoother-looking the printout. Graphics of low quality, if possible at all.	Letter-quality printouts	Very high quality output	Determined by dots per inch (dpi) produced
Colour available	Not available	Color printers available at cheaper than laser printer	Colour laser printers are available but very expensive	Color printers available
Cost	Inexpensive	Cost of printer is inexpensive but ink is costly	Depending on size, cost ranges from reasonable to very costly. Running costs are higher than impact printers but lower than most ink jet printers.	Expensive initial costs but cheaper to operate per page
Speed of printing	Can be slow	Slow, one page may take up to 10 minutes	Very fast. Typical home laser printers can print 8 pages per minute (ppm).	Fast, but it depends on the size of the file being printed.
Noise factor	Loud	Relatively quiet	very quiet	Relatively quiet

OTHER TYPES OF PRINTERS

There are two other types of printers that act as an output device for personal and office use.

Thermal printers use wax and heat to burn images on special paper. Some older fax machines that use rolls of papers are considered thermal printers. These printers are expensive to buy, and the paper is expensive compared to plain paper. Thermal printers are used by organizations, like publishers, who require top quality output.



Multifunction printers are output devices that can print, scan, copy, and fax a document using the same platform. Most look like a photocopier but can perform these other functions. However, if one component malfunctions, then the other components cannot be used since the entire printer must be sent out to be repaired.

TERMINALS – AS INPUT AND OUTPUT DEVICES

It is probably best to discuss terminals here now that input and output devices have been explained. A terminal enables a user to communicate with a computer and is generally a combination of a keyboard and output screen. Some users only need keyboards and monitors for the most basic task of simply input of data and output the data to verify that it is what the user entered.

Three types of terminals exist:

- Intelligent Terminal - This is another term for a typical computer system, with its own micro-processor, memory and storage devices. Examples of these terminals are automatic banking machines (ABMs) or Point of Sale terminals found mainly in supermarkets.
- Smart Terminal - This type of terminal comprises a monitor that displays features such as bold characters as well as characters that blink on the screen. This monitor therefore has its own processor. This is an older term, and today all PCs and laptops would be considered smart terminals.
- Dumb Terminal - This terminal is simply an output device that has a monitor to display information from a server or mainframe computer. It also has a keyboard for simple data entry, but more importantly it has no means of storing any data input and has no processing capabilities, A dumb terminal needs to be networked and data input into a server or smart terminal.

Activity 5.8 - Choose the most appropriate response for each of the following questions on output devices

The most suitable output device for producing a few colour brochures cheaply would be

- (a) an inkjet printer
- (b) a laser printer
- (c) a dot matrix printer
- (d) a plotter

The most suitable output device for producing a wage slip where the details need to be printed through multi-part (carbon) paper would be

- (a) an inkjet printer
- (b) a laser printer
- (c) a dot matrix printer
- (d) a plotter

The most suitable output device for an architect to produce large plans would be

- (a) an inkjet printer
- (b) a laser printer
- (c) a dot matrix printer
- (d) a plotter

The most suitable output device to quickly produce a large amount of high quality black and white printouts would be

- (a) an inkjet printer
- (b) a laser printer
- (c) a dot matrix printer
- (d) a plotter

An ink-jet printer is an example of a(n)

- (a) Laser printer
- (b) Impact printer
- (c) LCD printer
- (d) Non-impact printer

TOPIC SUMMARY

We have now explored a variety of output devices. Almost all business environments will need printers and monitors to review the data in hard or soft form. But some businesses may require speciality devices to print receipts, share visuals, or support data sharing in different ways. You must consider your data formatting and output requirements as part of your business planning process.

TOPIC 3 - STORAGE DEVICES

INTRODUCTION

Secondary storage is used to save your data when the computer is turned off and is cheaper than primary memory. Secondary storage, also known as mass media, auxiliary storage, or simply storage refers to the various media on which a computer system can store data.

OBJECTIVES

After studying this topic, you will be able to:

1. Explain the purpose of a storage device.
2. Describe the characteristics of storage devices.
3. Explain how storage devices access data.
4. Distinguish between magnetic storage devices and optical storage devices.
5. What is the difference between sequential access and random access.
6. List the various types of compact disks.
7. State the levels of the storage hierarchy.

OVERVIEW

Storage devices typically hold programs and data in manageable blocks or units called files. It is the primary memory that is used together with secondary storage to temporarily transfer the contents of a file between the two while the file is being used.

Some of the advantages of using secondary storage include:

- a vast amount of data or files can be stored in one location;
- reliable and safe storage of data and information;
- easy and quick access to data; and
- cheaper cost in storing data compared to using multiple filing cabinets.

Activity 5.9 - A school has 200 students who are learning Information Technology for an external exam. The administration of the school generally keeps records of the students, as well as the teachers' payroll information and the alumni association.

Consider the types of storage devices that would be necessary in the day-to-day work for the students, teachers and administration. If the school needs to backup all data, due to the threat of a hurricane, then explain if any secondary storage devices would change

from the day-to-day tasks.

[Turn to Appendix One for Suggested Response](#)

CATEGORIES OF STORAGE DEVICES

Storage devices are categorized in the following ways:

- Access method for data and information.
- Storage technology.
- The Storage Hierarchy.

Let's examine each one.

Method of Access

The method of access is further sub-divided into two sections, sequential access and random access.

Sequential storage devices (also called serial storage devices) are those that must start from the beginning of the data to be read from or written to, and proceed through each unit after the other in a sequence, until it reaches the required point. Therefore locating data using sequential access takes different lengths of time, depending on where in the list the data is located. Examples of sequential storage devices are cassette tape drives, where the drive forwards or rewinds the tape until it reaches its required target.



Random access storage devices can access data immediately without having to begin through to where the data is located. They search data based on a table of contents for the data located on the device. Examples of these storage devices are floppy drives and hard disk drives. These devices are also known as machine access, and direct access storage devices.

Floppy disks are still common with students who are now beginning to learn Information Technology, since they are relatively cheap. But these storage devices are quickly being replaced by portable flash drives and CD ROM and DVD disks. The future of the floppy disks is going the same way as beta tape recorders. Students who have projects small enough to store on a floppy, can transfer these files from one computer (possibly at home) to another (computer at school), while working on the project.

Storage Technologies

Again, storage devices can be further sub-divided into magnetic and optical devices.

Magnetic Storage Devices

If a storage device used disks (diskettes) or tapes, then it is categorized as a magnetic storage device. This is because disks and tapes are coated with iron oxide, a magnetically sensitive material used for storing the data.

The benefits of using magnetic storage devices such as 3½” floppy disks, hard disks and magnetic tape is that they can cheaply store large amounts of data. Magnetic tapes are also similar to those previously used to record music, and are popular for use in the backup of data.

A hard disk is a storage device which can retrieve data very quickly and can also store large amounts of data, many times more than a floppy disk or cassette tape. They contain multiple metal disks called platters, with read/write heads for each side of each disk.

The time taken to retrieve data includes the time taken to find the data on the disk (called access time) and the time taken to transfer the data from the disk to primary memory. The average hard disk has an average access time of 12 kps (Kilo-bytes per seconds). A fast hard drive is considered 8 kps.

If a storage device uses laser technology, then it is categorized as an optical storage device, since it uses laser beams to read data etched into plastic disks. Simplistically the surface of the disk will contain tiny indentations called pits. As a light-sensing device scans the surface, it picks up signals to interpret the data. For example, it receives no light from the pits, or light if no pits are scanned, thus sending a series of signals to the computer. The compact disk, more commonly called a CD, is the general term for these storage devices.

Optical disk storage also stores a larger amount of data than floppy disks, and are usually categorized according to their ability to read or write or both read and write data to the disk. They are generally used for mass distribution of information such as music, video, or computer programs. Standard CDs can store approximately 80 minutes of music.

Table 6.1 Categories of Compact Disks (CDs)

Optical Disk Type	Meaning	Description
CD-ROM	Compact Disk- Read Only Memory.	The drive can only read data from and <i>not</i> write data to the disk. Stores up to approximately 700MB of data on one disk. Primarily used for distribution of many types of software. They are used for storing large application programs, and multimedia programs.
CD-R	Compact Disk- Record (once)	Can be read from and written to. Note however that disks can be written to only 'once'. Disk can be read by either a CD-ROM or CD-R drive.
CD-RW	Compact Disk- Re-Writable	Disks can be read and written to many times and are therefore erasable. CD-RW drives are capable of reading, writing, and erasing data. Note that the write operation is much slower than the read operation, and hence not as popular as the others.
DVD-ROM	Digital Video Disk-Read Only	Mainly used for video storage (DVD-Video) but can also hold audio. DVD-ROM device is used for computer data storage.

Table 5.2 Comparison of storage capacity and access speed among storage devices

Storage device	Storage Capacity	Access Speed
Hard Disk	varies	1000 Kb/s
CD-ROM	~650 MB (~451 floppy disks)	100 Kb/s
DVD	~ 4.7 GB (~7 CD-ROMs)	100 Kb/s
Floppy Disk	1.44 MB	36 Kb/s

Solid State Storage Devices

Solid state storage devices are electronic and have no moving parts like the other mechanical storage devices such as the hard drive. Examples include flash memory sticks for storing general files, memory cards for video game consoles, and other devices used in digital cameras, disks in laptops. Flash memory is a type of EEPROM chip but it used more as a hard drive for data storage. These popular memory stick or flash drive is quite similar in use to floppy disks but contain much more data, so that it offers potential advantages over other portable storage devices. They are however more compact, generally faster, hold more data, and are more reliable than floppy disks. Memory cards are also similar to the memory stick. However they are for use in devices such as portable music players, personal digital assistants (PDAs), digital cameras, camcorders, mobile phones and computer systems.

Activity 6.2- The floppy disk was previously used as the typical method for distributing software adopted by software houses and developers.

Describe one occasion where it would still be sensible to use a floppy disk for software distribution. (2)

State two different ways, other than by floppy disk, in which software can be distributed. Turn to

[Appendix One for Suggested Response](#)

THE STORAGE HIERARCHY

Data is stored according to how quickly it is available to the computer system. The three main storage levels are compared in table 6.3

Table 6.3 – Description of Storage Hierarchy

Online storage	This is primary storage. These storage devices are readily available computer system, and there the user is not required to issue any instructions.
----------------	---

Near-online storage	This is secondary storage. The user usually needs to insert a disk in order to access the data implying that some intervention from the user is required to make the data available to the computer system.
Offline storage	This is also tertiary storage or archival storage, since this is not usually available to the computer system. A tape backup unit for archiving is an example.

TOPIC SUMMARY

Data storage is critical to any business. You must protect your data and store in a way that if anything happened to the computer system that it could be restored on another similar system. Critical data should be stored offsite and backup systems should be in place to save data on a regular basis.

RECOMMENDED UNIT READINGS

After you have completed your review of each Topic and its related activities, you should read at least TWO of the following online articles and consider the related reflective questions as you read the materials.

Soojung-Kim Pang, A. (2002). Mighty Mouse. Stanford Magazine. Available at: <http://www.stanfordalumni.org/news/magazine/2002/marapr/features/mouse.html>.

This article explores the evolution of the mouse as an input device.

Hersh, J. (1998). The Tyranny of the Keyboard. FAQ Typing Injury. Available at: http://www.tifaq.org/articles/keyboard_tyranny-feb98-jay_hersh.html.

This article explores the evolution of the keyboard as an input device.

Murat, J.K. (2007). How Do Laser Printers Work. Ezine Articles. Available at: <http://ezinearticles.com/?How-Do-Laser-Printers-Work?&id=747072>.

A short article on the inner workings of a laser printer. After

reviewing one or more of the above articles consider:

How have input and output devices facilitated humankind's need to capture, store and create new knowledge?

Brain, M. (ND). How Hard Disks Work. HowStuffWorks.com. Available at: from: <http://www.howstuffworks.com/hard-disk.htm>.

Tyson, J. (ND). How Flash Memory Works. HowStuffWorks.com. Available at: <http://www.howstuffworks.com/flash-memory.htm>.

After reading the two articles consider the following question:

What type of storage device is appropriate for my personal use? Is my storage needs the same as others?

Summary of Output Devices

The following concepts related to output devices was discussed in this unit:

- Two general types of output are softcopy and hardcopy output.
- Monitors enable the user to view the computer's processed data. The output is known as soft copy.
- Softcopy output can be further sub-divided into visual output (on screens) and audio output (from speakers).
- Two types of monitors are the cathode ray tube (CRT) and the liquid crystal display (LCD).
- A monitor's quality is measured by screen size, resolution, and refresh rate.
- Printers produce permanent copies (hard copies) of the computer's output.
- Visual output of text, graphics, or video is usually displayed on a monitor.
- A terminal enables a user to communicate with a computer and is generally a combination of a keyboard and output screen.

Input devices can be categorized by keyboard, pointing and data entry from the source. Each category has its own advantages and disadvantages although some users are somewhat inclined to use some types over others. The main concern with input devices is the health concern with regard to keyboards and the constant typing, which has led to the creation of the input devices which capture the data from the source.

Output devices are either softcopy or hardcopy output. Softcopy is usually temporary output while hardcopy output can be printed and stored for future use. The various types of soft- and hard-copy output must depend on the appropriateness of the application.

The concepts related to storage devices that were discussed in this unit included:

- Secondary storage is used to save your data when the computer is turned off and is cheaper than primary memory
- Storage devices typically hold programs and data in manageable blocks or units called files.
- Storage devices are categorized by the method of access to data (sequential or random-access), type of technology (magnetic, optical, or solid state), preference of storage (online, near-online, or offline) and type of operations that are performed (read-only or read/write)
- A hard disk's performance is measured by its positioning performance and transfer rate.
- Optical storage devices include, CD-ROM (Read-only), CD-R (Record once), CD-RW (Erasable, write repeatedly), DVD-ROM (Read-only), and DVD-R (Read/write).
- Solid state storage devices include PC cards, flash memory cards, and smart cards

Secondary storage is very important in the long-term storage of data and information. However the appropriate use of these devices depend on the method of access to data, the type of technology, the user's preference of online or offline storage as well as the type of operations that are to be performed.

Unit 12: Communications and Connectivity

12

INTRODUCTION

This unit is an interesting, but technical one where the discussion expands to the connection of more than one computer to meet various needs. It also discusses how these computers can be connected and the accompanying reasons or purpose for their connections. The popular topic of the Internet is also introduced with its intriguing services and benefits, and the different methods of connecting to the World Wide Web.

UNIT OBJECTIVES

At the end of this unit, you should be able to:

1. Describe the various uses of telecommunications.
2. Evaluate the different communication media.
3. Define a network.
4. Describe and illustrate the various types of networks.
5. Describe types of networks.

This unit is divided into two topics:

Topic1: Communicating using Technology

Topic2: Connecting Computers

TOPIC 1 - COMMUNICATING USING TECHNOLOGY

INTRODUCTION

Computers are linked together to exchange data and share resources as said to be networked. Networks allow users communicate with others once there is access to a computer. Networks come in a variety of forms and support a variety of different asynchronous and synchronous communications methods.

OBJECTIVES

After studying this topic, you will be able to:

1. Explain how telecommunications has expanded the presence of the computer.
2. Evaluate telecommunications' use in various activities.

COMMUNICATIONS

In our day to day lives we regular communicate with others through talking, writing, and actions. Computer networks communicate by first becoming linked to each other, so that data and resources can be shared. For example, two or more computers can be connected to each other, along with one printer (a resource), so that each computer is able to print from this one printer. This is known as a simple network and you are sharing output devices via the network.

Activity 6.1 - Discuss one other advantage and one disadvantage of sharing (a) data and (b) resources, in a network.

Turn to Appendix One for Suggested Response

Computer communication is achieved when signals are sent and received among and between different computers. This exchange of signals allows users to collaborate with other online users in different countries. Individuals can share and retrieve information and files they can exchange electronic mail and participate in electronic messaging with others from all over the world.

Collaboration and Sharing

Computer communication has provided contact among users from different cultures, continents, and time zones. Indeed, *telecommunications* technologies such as land lines, satellite, cable, the Internet and cell phone technology have made communication possible and affordable over long distances. Many business organizations and individuals have taken advantage of *teleconferencing* and *videoconferencing* – conferencing available on the Internet, and through you telephone, cable and satellite providers. Today people do not have to travel for meetings or conferences. Telecommunications technologies allow employees to work from home, or away from the office, while still interact with the others

in the company through computer communications. They are able to send and receive documents, share schedules, send messages and talk directly with their co-workers. This 'work away from the office, is known as *telecommuting*.

Activity6.2- Discuss advantages and disadvantages of using telecommunications and teleconferencing among small, medium and large businesses.

Turn to Appendix One for Suggested Response

TRANSACTION PROCESSING

In previous years data and information were stored in a central location, and many users would simultaneously access this single location to retrieve data required for a transaction, or other reasons. This caused problems, as not everyone was able to access data in a timely fashion. Large numbers of requests to a central processor or storage location takes time taken to send and retrieve the large or small amounts of data or information. The volume of data moving through the system often slowed the system down and at times even crashed or shut down the system. With computer communication systems now available, data and information (and indeed the workload) can now be dispersed (or distributed) to various sites, subsidiaries or branches of the business in other areas of the building or country.

Activity7.3- Give a disadvantage of having all of a company's data and information stored in one location. Explain the measure(s) should this company implement to secure its data and information.

Turn to Appendix One for Suggested Response

Indeed many large corporations link some parts of their systems with the systems of their major customers. This inter-organizational system link also allows the corporation's systems to link to suppliers for electronic data interchange (EDI). This facilitates speedy order processing and other transaction processing.

INFORMATION RETRIEVAL

Information retrieval is important for decision making in business, industry, research organizations, and even for entertainment. Various types of information (such as music, text, sound) can now be stored in private or public databases. Once these databases are made available online, they can be accessed by select persons either through the use of the Internet, or an internal company network, called an Intranet.

Activity 6.4 - 'Ringtones' and current music clips can be accessed through online databases and downloaded from the Internet. Identify some of these websites. Also identify websites where you can locate the following items:

1. size 8 brown shoes (you choose whether male or female shoes and the style!).
2. 185/14 Dunlop (or Michelin) car tyres.

Notice that as you search for the item, you are accessing large databases, and narrowing the search each time until you find your item

Turn to Appendix One for Suggested Response

ELECTRONIC MAIL AND ELECTRONIC MESSAGING

Electronic mail and electronic messaging are one of the most popular methods of communicating among persons of all ages. Messaging includes text messaging using cellular phones, online messaging using programs such as MSN and Google talk. Paging, sending and receiving sending faxes and the use of voice mail are also methods of electronic messaging. Electronic mail (e-mail) and online messaging also enables persons to send and receive softcopy documents as attachments.

Activity 6.5 - Electronic messaging has become an integral part of many cellular phone users' daily communication. Discuss the difficulties in written communication that may arise from employees' continued daily use of slang, such as 'u' for 'you', '4' for 'for', and AFAIK for 'As far as I know'.

Turn to Appendix One for Suggested Response

EFFICIENT AND EFFECTIVE COMMUNICATION

In order for computer communication to be effective and efficient, many agencies must be involved. These include the telecommunications telephone, cable and satellite companies in the various countries, as well as the many Internet Service Providers who provide access to the Internet. Indeed the number of businesses that are involved in the operation and management of Information and Communications Technologies (ICTs) include: software providers; hardware providers; custom development companies; online communications and collaboration companies; and others. Finally governments must create legislations that governs the access to data and the use of data and provides oversight of the telecommunications industry.

TOPIC SUMMARY

In the 21st Century communications is critical to any business operation. As you begin to build your business enterprise you must consider the type of communications you need to communicate to your potential clients, your providers and to others engaged in your business.

TOPIC 2 - CONNECTING COMPUTERS

INTRODUCTION

This Topic is a bit technical as it describes the media that are used to connect computers together in order to share data and peripheral devices. There are also different ways in which computers are connected and it discusses the advantages and disadvantages of each. The Topic also includes a brief discussion on the services and benefits of the Internet, and the various methods for connecting to the world wide web.

UNIT OBJECTIVES

After studying this topic, you will be able to:

1. State the components that link communication systems.
2. Differentiate among the network topologies.
3. Describe the differences between local area networks (LANs) and wide area networks (WANs).
4. Explain the services and benefits of the Internet.
5. Discuss methods for connecting the Internet.

COMMUNICATION SYSTEM COMPONENTS

Wired or wireless media are used to allow communications among computers. Wired media include twisted-pair, coaxial and fibre optic cable. Twisted-pair cable and coaxial cable transmit data by means of electric frequencies. These cables therefore need to be protected against water and electromagnetic waves. Fibre optic cable is an improvement on the previous two cables. A fibre optic cable consists of glass or plastic tubes which transmit data over longer distances at a faster speed, using reflection of light. Fibre-optic cables are more secure and much thinner and lighter than other metal wires, and they are not affected by electromagnetic noise such as radios, motors and others cables. Although fibre-optic cables are very costly and difficult to install, they are extremely popular with telephone companies, banks, and television companies replacing their existing telephone and coaxial cables with more efficient fibre-optic cables.

As the term implies, wireless media in a telecommunications network connects nodes without the use of wires. Wireless network systems incorporate cellular technology which uses satellites, radio and other signals, to allow for communication over land and sea across the world. Wireless networks are very useful in sending and sharing data quickly within small offices or among business across the world. More importantly they are relatively inexpensive in connecting to the Internet, especially in countries where there are scarce resources or poor infrastructure. Wireless networks therefore eliminate the maze of cables, while offering more mobility. However the disadvantage of wireless media is interference from other networks that might block the radio signals from passing through.

NETWORK TOPOLOGIES

The physical layout of a network is called a topology. The four main topologies will be discussed in this section.

A network is a collection of computers which are connected together. When sketching the topology, each computer workstation, file server or other peripheral is generally called a node. A network

topology therefore, is the arrangement of the network, whether physically (the actual layout including cable installation), or logically (the actual operation of transferring data), according to the requirements of the network. This Topic will discuss four general network topologies.

Bus Topology

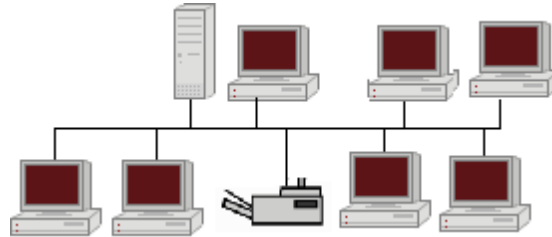

This linear bus topology is one of the simplest of the four network topologies to use, in its most basic form it is simply a case of running one cable called a backbone, from the computer or peripheral device at one end of the network to the last peripheral device or computer at the other end. Other computers, scanners, printers or other peripheral devices are then attached to the backbone anywhere between these two end computers.

Advantages and Disadvantages of Bus Topology

Of course from the simple description above, it seems relatively easy to connect a computer or peripheral to this topology. It also requires less lengths of cable than the other topologies, so it can be economical.

Since all computers and peripherals depend on this single cable or backbone, the entire network will not work if there is a break in the backbone. This will also prove difficult to identify where the problem or break is located, if the entire network is not working. This topology is also not intended to be used as the only network arrangement where numerous computers and peripherals are to be connected. Finally it has the lowest fault tolerance, that is, a single problem in the network with a bus topology can halt all of its activities.

Star Topology

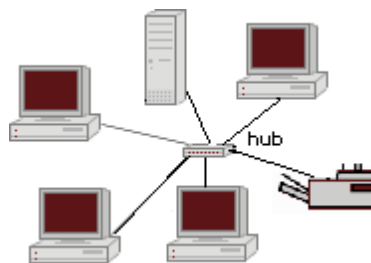

A star topology connects computers and peripherals to a central device called a hub. Physically the topology looks like a star. So that when a node is sending data to another node, the data passes through the hub before continuing to its destination node. The hub therefore manages and controls the network.

Advantages and Disadvantages of Star Topology

A new node is relatively easy to install by adding a cable from the new device to the hub. Installing and even removing nodes do not cause any disruptions to the network, so this topology has high fault tolerance when troubleshooting to detect faults and to remove nodes.

Of course if the hub fails, then all nodes attached to the network are disabled. It is also more expensive than the bus topology because of the cost of installing the cabling and configuring the hub.

Ring Topology

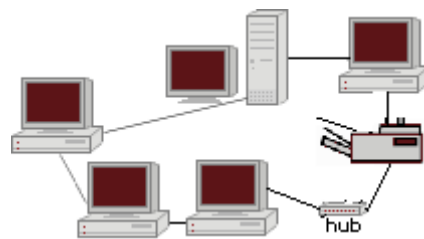

The nodes in a ring topology are connected to the nodes on its left and right, so that data passes from one node to the next. Of course fault tolerance is non-existent since failure of one node cripples the entire network. This is why the physical ring topology is rarely used. Adding a new device to an existing physical Ring network can be complicated as any new device needs to go in-between the existing devices.

LOCAL AREA NETWORKS (LANs)

A Local Area Network (LAN) is a computer network that functions within a specific geographical area, such as a building, school or campus. The network links the computers located within the building. In the case of a campus, the computers are linked throughout the various buildings using wired cables or wireless communication using radio and other signals. Access to the LAN is privileged and controlled by a network administrator. Once access is authorized, users can access most of the software, data, and peripherals connected to the LAN. The main uses of LANs include the sharing of expensive devices such as printers and scanners, as well as the provision of internal Intranet and electronic-mail services. Public telephone exchanges such as PBXs are also examples of LANs which use telephone systems in many organizations.

In order for a LAN to function, a network interface card (NIC) must be installed in the computer to provide the connection between the computer and the network. The main operating system software that supports networking are UNIX, Linux, Windows, and Mac OS. Two types of LANs are peer-to-peer and client-server, which employ a bus or ring topology.

PEER-TO-PEER NETWORKS

All computers on a peer-to-peer network are configured similarly with no specific computer designated as a file server. Also the users in this type of network determine which files and peripherals attached to their computer that they wish to share. This is why peer-to-peer networks are simple to set-up as home businesses, and are not appropriate when there are many computers.

CLIENT-SERVER NETWORKS

Client-server networks can be set up using various topologies, and are appropriate in large corporations. The network requires file servers which contain the many application programs. The clients are the networked computers which access the server to obtain and use the programs, data,

and to access peripherals.

WIDE AREA NETWORK (WAN)

Wide area networks (WANs) effectively connect LANs which are located at different geographical locations – a few miles or thousands of miles away. This way, a large corporation or banking institution can share, and exchange data and information, as well as perform transactions among its branches using one wide area network system.

Internet Services and Benefits

The Internet is a network of networks, which link local, regional, national and international computer networks to exchange data and process tasks. In order to efficiently process these tasks and exchange data, a standard called TCP/IP (Transmission Control Protocol/ Internet Protocol) comprises a set of rules which must be followed. The telecommunication links among the networks of the Internet are built and maintained by major telecommunications companies around the world. Each computer connected to the Internet is recognized by a unique number, officially known as an 'IP Address'. Data travels the Internet from origin computer to destination computer in small chunks called 'Packets', with the help of 'routers'.

CONNECTING TO THE INTERNET

Users can connect to the Internet through a dial-up connection or other more sophisticated connections. Irrespective of how users connect, companies called Internet Service Providers (ISP) maintain telecommunications equipment so as to provide Internet access to individual users, as well as users involved in business and large organizations. An ISP is responsible for providing each user with Internet access by connecting your computer to the Internet, much like a telephone company connects your phone to the telecommunications network. To get access to the Internet, a user needs an optional local telephone number, a unique identification and password for access, and one or more email addresses. This is usually accompanied by a stipulated fee monthly, quarterly, yearly or simply a block of hours.

Activity 6.6 – Identify some of the local Internet service providers in your country, and visit their web sites. Compare the costs of dial-up and faster Internet connections, as well as speeds of connectivity for each one.

Turn to Appendix One for Suggested Response

DIAL-UP INTERNET CONNECTION

A dial-up connection requires a device called a modem, which converts your computer's digital signals into a type of signal that can travel over phone lines. The maximum speed for dial-up is 56Kbps, or 56,000 bits per second.

OTHER INTERNET CONNECTIONS

Other Internet connections provide data transfer speeds much faster than that of a dial-up connection, although they both must be in close proximity to a telephone port. An Integrated Services Digital Network (ISDN) provides data transfer speeds of 128K, while a Digital Subscriber Line (DSL) is a general name for a family of high-speed Internet links, including ADSL, SDSL, and DSL lite. These provide data transfer speeds up to 125 times faster than dialup.

Activity 7.7 - Explain the meaning of the terms as well as any differences among ADSL, SDSL, and DSL.

Turn to Appendix One for Suggested Response

Web Browsers

Just as you would use a software program such as a word processor, web browsers are also software programs that are also installed on your computer. Their purpose however is to allow you to access one or more web pages. In simpler terms, a web browser is just a way to help you get around the Internet, so whenever you type in an address for distance education to access your notes, for example, you are using a browser. Browsers are also useful for downloading files from databases stored on the Internet, and linking you to other pages from a main home page. Each browser keeps a list of the pages you have viewed on the Web, so that you can return to that site, even if you visited it days ago.

A typical web page contains mostly text, with some pictures, and even media such as movies or other small programs. Your browser translates the HTML language that was used to create each web page into a presentable form that users can understand. Figure 5.1 shows a typical browser while figure 5.1 shows the html code that was used to create the web page.

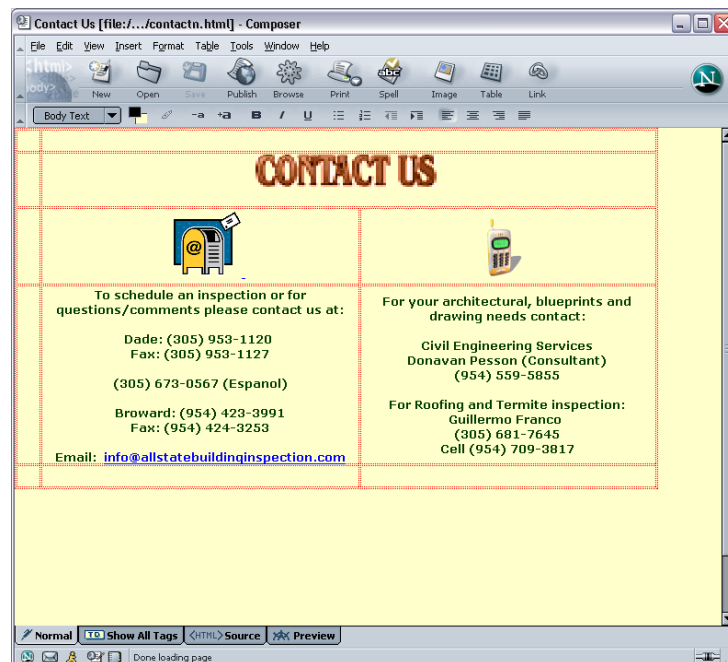

It is important that browsers provide efficient ways to manage bookmarks, cookies, tabbed browsing, pop-up blocker as well as have ample security options. Users may even prefer auto-fill capabilities for web-based forms.

Activity 7.8 - Write short notes to explain the purpose of bookmarks, cookies, tabbed browsing, pop-up blocker, security options, auto-fill capabilities for web-based forms, as they relate to Internet Browsers.

Turn to Appendix One for Suggested Response

There are many different browsers available, although the popular one is Internet Explorer (or IE). However all browsers should be able to load web pages without much difficulty and at about the same speed.

SEARCH ENGINES

Search engines access many web sites which match your request, and then show a list or sample of the web pages so that you can select those that you are interested in. generally, search engines carry out some of the following tasks. Gather a list of web pages:

- Based on a user's search for a word, phrase, web page or similar option.
- Through listing each page that contains the search word or similar words.
- If the search word is an embedded link on a web page, then the search engine peruses that link also.
- Rank the search results by web pages that contain or link to that search term most frequently.

Problems with Searching

169

Search for a word or phrase in a browser window, will produce those web pages that are relevant to what you are searching for. However, words and phrases differ in context, so you may also see other listing which do not relate to what you need. In addition, you may also see duplicate listings since the search will list the web page with your search term, as well as all of the links from the same web page that also contain the search term.

Activity 6.9 - Internet cookies or web cookies are used to collect basic information on users as they visit web sites. Perform a search on the Internet for the term 'cookie'. Note how many pages of results are produced. Also peruse two or three pages and note how many web sites show results that may be relevant to the search term. Remember you are looking for the sites based on cookies relating to the Internet! Make a note any web sites that have no relation to the search term.

Turn to Appendix One for Suggested Response

World Wide Web Basic Terminology

Link	A button or interaction that allows you to navigate to related documents.
Web Page	A collection of hypertext documents and links (or hyperlinks).
Web Server	A computer that stores and distributes web pages.
Web Site	A collection of web pages with an Internet address.
HTML (Hypertext Markup Language)	A language to create web pages. The file extensions used are .htm or .html
HTTP (Hypertext Transfer Protocol)	The communications standard that is used to transport web documents over the Internet.
Hypertext	Text, video, pictures.
The Web (or World Wide Web)	A collection of files that are interconnected through of hypertext.
URL (uniform resource locator)	The internet address of a web site.

TOPIC SUMMARY

As you grow your business you will hire employees, engage contractors and seek out a wide variety of providers to support your business growth. As noted in earlier topic discussions communications and data sharing are critical to the success of any business. At some stage of your business growth you will need to create your own network. This can be in the form of a virtual network using the Internet or creating your own internal LAN or WAN. This will allow those engaged in your business to

communicate and share in a timely, controlled and secure manner.

RECOMMENDED UNIT READINGS

After you have completed your review of each topic and its related activities, you should read the following online article and consider the related reflective questions as you read the materials.

NCI Frederick Communications. (2005). Networking Introduction. Available at:

<http://comm.ncifcrf.gov/networking/networkintro.html>.

After reviewing the article think about the complexity of the networking environment and consider:

Can organizations, businesses and governments afford to continue to develop corporate, regional and national networks? What is the potential impact on society if they do not?

UNIT – SUMMARY

The concepts in this unit include:

- Computer networks communicate by first becoming linked to each other, so that data and resources can be shared.
- Computer communication allows for collaboration among users in different countries, transaction processing, retrieval of data and information, electronic mail and electronic messaging from all over the world.
- Wired or wireless media are used to allow communications among computers.
- Wired media transmit data by means of electric frequencies.
- Wireless media connects computers without the use of wires.
- The physical layout of a network is called a topology.
- Linear bus topology is one of the simplest of the four network topologies to use.
- Star topology connects computers and peripherals to a central device called a hub.
- Ring topology are connected to the nodes on its left and right, so that data passes from one node to the next.
- A Local Area Network (LAN) is a computer network that functions within a specific geographical area, such as a building, school or campus.
- Wide area networks (WANs) connect LANs which are located at different geographical locations.
- The Internet is a network of networks, which link local, regional, national and international computer networks to exchange data and process tasks.
- Web Browsers are also software programs that are also installed on your computer.
- Search engines access many web sites which match your request, and then show a list or sample of the web pages so that you can select those that you are interested in.

In the previous units we explored the input, processing, storage and output of individual computers. This unit introduced communication among computers once they were linked together in different ways to form a network. It thus enabled the user to engage in telecommunication, teleconferencing and then telecommuting.

In addition, access to data located on other computers, called servers, allowed for faster retrieval, and thus the introduction of electronic mail and electronic messaging, and the development of the Internet. Users are now able to search for any item whether it is a product, a plant or a planet!

FINAL ASSIGNMENT

The final assignment is a self-paced self-learning project that will require participants to have access to word processing, presentation and spreadsheet software. If you are not familiar with the office software you should work through the help sections/tutorials that are available in most office software. There

The major assignment for this course is to produce a detailed analysis of the hardware, software and network requirements for a small business and its growth over three to five years. The assignment will require the participants to produce the following:

1. Three to five page report using a word processor of your choice (e.g. MS Word, Open Office Word, etc.). The report should include:
 - a. Three references from the Internet with title and URL.
 - b. Reflect the use of word processor template with Title and Headings.
 - c. At least two graphics embedded into the report.
2. Presentation of five to ten slides that describes the technology solutions reflected in the written report. The participant may select the presentation software to be used to produce the project presentation. The layout of the presentation should include:
 - a. Graphics or simple animations to illustrate major points (minimum three required).
 - b. Use of different transitions.
 - c. Includes a title slide and summary slide.
3. The third part of the assignment is to create a spreadsheet that illustrates to cost of the equipment and the annual operation of the technology support required by the business. You should include the creation of a web site as part of the marketing solution. Participants may select the spreadsheet software to be used to produce the budget. The spreadsheet should:
 - a. A detailed list of costs.
 - b. Costs should be represented as either Capital costs (one time only) and Annual Operating costs (spent over a period of 12 months).
 - c. Should include costs related to hardware, software, networking, networked office equipment, Internet connections and operation, web site creation and any other related technology costs.

- d. The spreadsheet should illustrate start-up costs (what you need to buy right away) and annual operating costs.
 - e. Totals by quarter should be represented.
4. All three files should be emailed to your instructor for feedback and review. Your instructor will provide additional instructions on where and when to submit the assignment.

COURSE SUMMARY

FINAL READING ASSIGNMENT

Before we wrap up this course you should consider the future of computer technology and what it may be like in ten to twenty years from now. Our knowledge base is doubling every three to five years. We need ways of storing and sharing this new knowledge than some of the systems currently in place. Read the article below and consider some of the potential implications of these new and emerging computer technologies on how we do business in the future.

Herzog, C. (2006). The Future of Computer Technology. Geeks.com. Available at: <http://www.geeks.com/techtips/2006/techtips-26nov06.htm>.

COURSE SUMMARY

You have now completed this introductory course. It is hoped that the course has given you a solid understanding about how computer and information technology systems operate. Today's entrepreneur must embrace technology and to do so he or she must ensure they have a good grounding in the basics of ICT. This course will prepare you to complete the next course in the series "Business Information Systems" in the Business and Entrepreneurship Diploma programme.

Unit 13: Number System

Unit Introduction

In this unit, you will learn the basics of numbering systems; use of decimal, octal, binary and hexadecimal number system. You will also learn how to convert standard notation expanded numbers and how to convert from one binary system to another i.e decimal, octal, binary and hexadecimal data representation.. The unit will also introduce you to how a CPU's control unit interprets a machine-level instruction — either directly or as a micro-program. You will be able to identify, describe and analyze the gate symbols for the Boolean operations AND, OR, NOT and XOR. You will be introduced to how to construct a truth-table with the input/output behavior of each individual gate.

Unit Objectives

At the end of this unit, you should be able to:-

1. Demonstrate a good understanding of basics of numbering systems
2. Use decimal, octal, binary and hexadecimal number system
3. Convert: standard notation expanded numbers
4. Identify and analyze the gate symbols for the Boolean operations AND, OR, NOT and XOR.
5. Construct a truth-table with the input/output behavior of each individual gate and construct logic gates for different boolean operations.

Key Terms

Number system:- A set of values used to represent different quantities

Decimal Number System:- This consists of ten digits from 0 to 9. These digits can be used to represent any numeric value. The base of decimal number system is 10.

Binary Number System:- This consists of two digits 0 and 1. Its base is 2. Each digit or bit in binary number system can be 0 or 1

Octal Number System:- This consists of eight digits from 0 to 7. The base of octal system is 8. Each digit position in this system represents a power of 8

Hexadecimal Number System: This consists of 16 digits from 0 to 9 and A to F. The alphabets A to F represent decimal numbers from 10 to 15. The base of this number system is 16.

Boolean Operators are simple words (AND, OR, NOT or AND NOT) used as conjunctions to combine or exclude keywords in a search, resulting in more focused and productive results.

Number system

They are a set of values that are used to represent different quantities is known as Number System. For example, a number system can be used to represent the number of students in a class. The digital computer represents all kinds of data and information in binary numbers. It includes audio, graphics, video, text and numbers. They are represented by the computer as numbers it can understand. This group of numbers that the computer can understand is called a 'positional number system'. Some important number systems are as follows:-

- a. Decimal number system
- b. Binary number system
- c. Octal number system
- d. Hexadecimal number system

There is limited number of symbols in the number system called digits. These symbols represent different values depending on the position they occupy in the number. The value of each digit in a number can be determined by examining the digit is under consideration, the position of the digit in the number and the total number of digits in the number system. The total number of digits used in a number system is called its base or radix.

Decimal Number System

This consists of ten digits from 0 to 9. These digits can be used to represent any numeric value. The base of decimal number system is 10 as it uses ten digits. The value represented by individual digit depends on weight and position of the digit. Each number in this system consists of digits which are located at different positions. The position of first digit towards leftside of the decimal point is 0. The position of second digit towards left side of the decimal point is 1. Similarly, the position of first digit towards right side of decimal point is -1. The position of second digit towards right side of decimal point is -2 and so on. For example the number 435.6 has $4 * 10^2 + 3 * 10^1 + 5 * 10^0 + 6 * 10^{-1}$. The positions are often categorized as most significant if on the far left and least significant if on the far right.

On the other hand, Octal Number System is consist of eight digits from 0 to 7. The base of octal system is 8. Each digit position in this system represents a power of 8. The HexadecimalNumber System is consist of 16 digits from 0 to 9 and A to F. The alphabets A to F representdecimal numbers from 10 to 15. The base of this number system is 16.

It will be important to know how conversions can be done from one system to the other andparticularly to binary system.

Binary Number System

All data in a computer system consists of binary information. 'Binary' means there are only 2 possible values: 0 and 1. One binary digit (0 or 1) is referred to as a bit, which is short for binarydigit. These bits can be grouped together into larger chunks to represent data. Computer designers use eight bit chunks called bytes as the basic unit of data. Computer manufacturers express the capacity of memory and storage in terms of the number of bytes it can hold.

A single byte can represent many different kinds of data. What data it actually represents depends on how the computer uses the byte. Though we use the decimal number system when we input numbers as data or instructions, the computer represents these data as 0 and 1.

Example: For the decimal number 252 we have:

252

1111100

Decimal (Base 10)			Binary (Base 2)							
MS		LS	MS							LS
2	5	2	1	1	1	1	1	1	0	0
100	10	1	128	64	32	16	8	4	2	1
102	101	100	27	26	25	24	23	22	21	20

Adopted and retrieved from Representing signed integers by Dr. Dulay Oct. 2007 available at https://www.doc.ic.ac.uk/~eedwards/compsys/0_Notes1_Integers.doc

Here MS stands for Most Significant and signifies the leftmost digit or bit. LS stands for Least Significant and signifies the rightmost digit or bit.

The base of a number can be made to be explicit, for example

$$1410 = 168 = 11102 = 0E16$$

Decimal to Binary Conversion (Division)

One conversion technique is the repeated division by 2 and taking then recording the remainder.

Example: What is 9810 in binary?

(Adopted and retrieved from Representing signed integers by Dr. Dulay Oct. 2007 available at https://www.doc.ic.ac.uk/~eedwards/compsys/0_Notes1_Integers.doc)

Steps:

- Divide the number by 2 giving the quotient and the remainder.
- Repeat previous step with the new quotient until a zero quotient is obtained.
- The answer is obtained by reading the remainder column from the bottom to the top.

	Quotient	Remainder
$98 \div 2$	49	0
$49 \div 2$	24	1
$24 \div 2$	12	0
$12 \div 2$	6	0
$6 \div 2$	3	0
$3 \div 2$	1	1
$1 \div 2$	0	1

Answer: 110 00102 reading the remainder column from bottom to the top MS-bit to LS-bit

Octal Number System

(Adopted and retrieved from Representing signed integers by Dr. Dulay Oct. 2007 available at https://www.doc.ic.ac.uk/~eedwards/compsys/0_Notes1_Integers.doc)

Conversion of binary to octal

The rule of thumb is that you start from the least significant end and for each group of 3 bits represent 1 octal digit (called an octet). For example,

000 (0), 001 (1), 010 (2), 011 (3), 100 (4), 101 (5), 110 (6), 111 (7)

Consider the following examples

Example 1 : What is 101012 in octal?

10	101
2	5

(You group 101 right most and 10 left most and get 25)

Example 2: What is 3578 in binary?

3	5	7
011	101	111

Hexadecimal Number System

Hexadecimal system is used by programmers to represent long binary values. The symbols 0,1,2,3,4,5,6,7,8,9,A,B,C,D,E,F are used to represent the digits for this. The letters A to F can be in uppercase or lowercase. We start from the least significant end of the binary system and count 4 bits to represent 1 hex digit. The correspondence between the hexadecimal, binary and decimal is shown in the following illustration (Adopted and retrieved from Representing signed integers by Dr. Dulay Oct. 2007 available at https://www.doc.ic.ac.uk/~eedwards/compsys/0_Notes1_Integers.doc)

Hex	0	1	2	3	4	5	6	7	8	9	A	B	C	D	E	F
Decimal	0	1	2	3	4	5	6	7	8	9	10	11	12	13	14	15
Binary	0	1	10	11	100	101	110	111	1000	1001	1010	1011	1100	1101	1110	1111

Example 1.

Take an example of converting 25210 to hexadecimal. We first convert 252 base 10 to base 2 and get 1111 11002 . We then group them into 4 bits from the left and have (1111)=F and (1100) =C. 25210 = FC 16 .(Adopted and retrieved from Representing signed integers by Dr. Dulay Oct. 2007 available at

https://www.doc.ic.ac.uk/~eedwards/compsys/0_Notes1_Integers.doc)

You can convert binary to hexadecimal number by grouping 4 bits binary

numbers Example 1

$$0(1101)(1101)_2 = 0110 \ 1110 \ \text{group of 4 bits} \\ = 6 \ E_{16}$$

$$1101001101_2 = 0011 \ 0100 \ 1101 \\ = 3 \ 4 \ D_{16}$$

Example 2

$$1011100.1000101_2 = 0101 \ 1100.1000 \ 1010 \\ = 5 \ 12 \ . \ 8 \ 10_{16} \\ = 5C.8A_{16}$$

Conversion of hexadecimal number to octal number

Example

$$3DE_{16} = 0011111011110_2$$

Group 3 bits together from left to right then change each grouping to decimal number

$$= 001 \ 111 \ 011 \ 110 \\ = 1 \ 7 \ 3 \ 6_8$$

Addition of Binary Numbers

In the binary system the rules of binary when adding the number are as follows:

$$0 + 0 = 0$$

$$0 + 1 = 1$$

$$1 + 1 = 1$$

$$1 + 1 = 0 \ \text{with a carry of } 1$$

Example

a) Add $1001_2 + 0101_2$

Worked Solution

$$\begin{array}{r} 1001 \quad \underline{\quad} \quad 9 \\ 0101 \quad \underline{\quad} \quad 5 \\ \hline 1110_2 \quad \underline{\quad} \quad 14_{10} \end{array}$$

b) Add $0111_2 + 0101_2$

Worked Solution

$$\begin{array}{r} 0111 \quad \underline{\quad} \quad 7 \\ 0101 \quad \underline{\quad} \quad 5 \\ \hline 1 \ 100_2 \quad \underline{\quad} \quad 12_{10} \end{array}$$

Binary Subtraction

Binary Subtraction

Example

a) $1110 - 0101$

Worked solution

$$\begin{array}{r} 1110 \quad 14 \\ - 0101 \quad 5 \\ \hline 1001 \quad 9 \end{array}$$

b) $0101 - 0111$

$$\begin{array}{r} 0101 \quad 5 \\ - 0111 \quad 7 \\ \hline 1110 \quad -2 \end{array}$$

which is not true since the smaller value is subtracting bigger value computer use 2's complement to handle negative the solution as shown below.

Use 2's complement method

Complement means superimposing the largest value.

$$\begin{array}{r} 0101 \\ 0111 \text{ complement} \\ \hline 1101 \text{ complement this } 0010 \\ \hline 0010 \text{ which is true} \end{array}$$

Advantages of the two's complement format

1. Handles subtraction of integers as addition.
2. Therefore computer does not requires different circuits to handle addition and subtraction

Learning Activity 1

Details of the activity: Number system conversion [Estimated Time 2 hour]

Before attempting this activity, you read

1. http://www.tutorialspoint.com/computer_fundamentals/computer_number_system.htm - number system
2. <http://www3.ntu.edu.sg/home/ehchua/programming/java/datarepresentation.html> - A Tutorial on Data Representation: Integers, Floating-point Numbers, and Characters
3. <http://www.edupub.gov.lk/Administrator/English/10/ICT%20g-10%20E%20new%20syllabus/Chapter%203.pdf> - Data Representation methods in a computer system, chapter 3

Try the following conversions and see if the answers are as given.

1. Direct conversions

- a. Convert binary number 10102 to decimal number Answer 10_{10}
- b. Convert binary number 110012 to decimal number Answer 25_{10}
- c. Convert binary number 11111112 to decimal number Answer 127_{10}
- d. Convert 111 010 1012 into base ten Answer 25_{10}

2. Construct a table of numbers from 1 through 16 in decimal numbers and convert them into octal, binary and hexadecimal equivalent.

Adopted and retrieved from Chapter 6: Exercises and answers, Retrieved March 14, 2016, from web.nuu.edu.tw/~carlu/ecp.../Ans_CH06.doc and can also be seen http://www.rapidtables.com/math/number/Numeral_system.htm Rapid tables reference and tools. (n.d.)

Answer:- Expected table would look like

<i>binary</i>	<i>octal</i>	<i>decimal</i>	<i>hexadecimal</i>
000	0	0	0
001	1	1	1
010	2	2	2
011	3	3	3
100	4	4	4
101	5	5	5
110	6	6	6
111	7	7	7
1000	10	8	8
1001	11	9	9
1010	12	10	A
1011	13	11	B
1100	14	12	C
1101	15	13	D
1110	16	14	E
1111	17	15	F
10000	20	16	20

Retrieved March 14, 2016, from web.nuu.edu.tw/~carlu/ecp.../Ans_CH06.doc and can also be seen http://www.rapidtables.com/math/number/Numeral_system.htm Rapid tables reference and tools.)

Assessment

The Number system

1. Evaluate the the following

a. Convert 73_{10} to base 2 Answer 1001001_2

b. Convert 111_{10} to base 2 Answer 1101111_2

c. Convert 221_{10} into base 2 Answer 11011101_2

2. Evaluate the following

a. Convert $6B9_{16}$ to base 2 Answer 011010111001_2

b. Convert $6D.3A_{16}$ to base 2 Answer $0110\ 1101.00111010_2$

c. Convert $5B.3A_{16}$ to base 8 Answer $1\ 3\ 3.1\ 6\ 4_8$

3. Compute the following

a. $1010_2 + 1101_2$ Answer 10111_2

b. $1110_2 - 0101_2$ Answer 1001_2

Unit 14: Logic Gates

Logic Gates

In computer science, the Boolean data type is a data type, having two values (usually denoted true and false), intended to represent the truth values of logic and Boolean algebra. It is named after George Boole, who first defined an algebraic system of logic in the mid 19th century.

When one wants to build a computer, he/she begins with digital logic design. Nearly every computer is built using digital logic.

Boolean algebra is the mathematics that is used to analyze digital gates and circuits. The variables used have only two possible values, a logic "0" and a logic "1". A boolean expression, on the other hand, may have an infinite number of variables each labelled to represent input to the expression. A variable of the primitive data type boolean can have two values: true and false (Boolean literals).

For example, we may have the variables A,B,C which may be used to form a logical expression $A + B = C$. Each of these variables can individually have the values of either 0 or 1.

In computer operation with binary values, Boolean logic can be used to describe electromagnetically charged memory locations or circuit states that are either charged (1 or true) or not charged (0 or false).

Boolean functions may be practically implemented by using electronic gates. The following points are important to understand:

- Electronic gates require a power supply.
- Gate INPUTS are driven by voltages having two nominal values, e.g. 0V and 5V representing logic 0 and logic 1 respectively.
- The OUTPUT of a gate provides two nominal values of voltage only, e.g. 0V and 5V representing logic 0 and logic 1 respectively. In general, there is only one output from a logic gate except in some special cases.

Logic gates are the basic building blocks of any digital system and must be designed. It is an electronic circuit having one or more input and only one output. The relationship between the input and the output is based on a certain logic. Based on this, logic gates are named as

1. AND gate,
2. OR gate,
3. NOT gate,
4. NAND gate,
5. NOR gate,

6. EXOR gate etc.

For further reading: on logic gate available at

1. <http://www.ee.surrey.ac.uk/Projects/CAL/digital-logic/gatesfunc/>

2. http://www.slideshare.net/pong_sk1/basic-gates-and-functions

Example:

Left hand side represents boolean function and right hand side represent boolean expression

The left side represents the output, say, Y and it can then be stated that

In this section of the unit, you will learn about the characteristics of the various gates, their design and how they are.

Truth Table

A truth table is a table which is used to show the truth values of a sentence, known as a compound sentence, that is formed by using the logical connectives:-

- AND - both the variables are true
- NOT- the variables is true
- OR- either of them is true.

This is true for every possible set of combinations of the truth values of the sentences that form the compound sentence. The main purpose of a truth table is to show the function of a logic gate. These values, associated with the function, are normally given the logic values of 0, for false and 1 for true.

Thus, the following table shows the rules that apply:-

A	-A	B	-B
0	1	1	0
1	0	0	1

It is also true that $A + B = 1$ except when $A = 0$ and $B = 0$. This one says that either A is true (1) or B is true (1) or both are true. Whenever the two of them are false then $A + B \neq 1$;

$A * B = 0$, that is both A and B are false and the only exception is when $A = 1$ and $B = 1$ (both are true);

$A * B = 1$, that is both are true.

The behavior of any logic gates can be understood by examining the truth tables. You can find out how the inputs into the logic gate will be related to the output by using the rules that are used to establish the truth tables. Here, the inputs are shown in the left column of the table and this will include all the various input combinations. To make this easier, the inputs are normally mapped onto the binary logic values of 1 and 0. The gate output(s) are normally shown on the right hand side of the column.

Truth tables can be constructed by following the steps listed below:-

1. List the variables in ascending order of alphabet.
2. Create the rows where the number of rows will be 2^n where n represent number of variables
3. Create the column headings to be the same as the names of the variables.
4. Beginning from the rightmost column, insert alternate values of 0's (False's) and 1's (True's) in the rows until you exhaust the rows.
5. You move to the immediate left column and insert pair of alternate 0's (False's) and 1's (True's) in the rows until you exhaust the rows.
6. Continue to the remaining columns while doubling the 0's and 1's until all the columns have been completed.

At the end of the activity, you will notice that the first horizontal line (row) will have all 0's and the last will have all 1's. You will also notice that leftmost column will be divided evenly where the first half will have all 1's and the second all 0's.

For example, suppose we have only one variable, say, p . This has two possible truth values, 1 and 0. We can then construct a truth table like the one shown in Table 2.1.

p
1
0

Table 2.1: Truth table of one variable

If we have two possible variables, say, p and q . there are four possible truth value combinations, that is, 11, 10, 01 and 00. The net effect is that there will be four rows as shown in Table 2.2.

p	q
1	1
1	0
0	1
0	0

Table 2.2 : Truth table for two variables

AND Gate

This gate got its name because of the logical “AND” operator that requires that the values of the participating variables be either both true or both false. The output will be if both inputs are TRUE else it will be “false”.

In the Logic Diagram below, shows the AND gate.
 Adapted from Basic gates and functions. Retrieved September 03, 2012, from http://www.slideshare.net/pong_sk1/basic-gates-and-functions and Logic gates. Retrieved April 28, 2016, from http://www.tutorialspoint.com/computer_logical_organization/logic_gates.htm

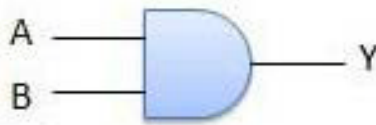

Figure 2.1- AND Gate Logic diagram

Truth Table

INPUT		OUTPUT
A	B	AB =Y
0	0	0
0	1	0
1	0	0
1	1	1

Table 2.3- Truth Table for AND Gate

OR Gate

Adapted from Basic gates and functions. Retrieved September 03, 2012, from http://www.slideshare.net/pong_sk1/basic-gates-and-functions and Logic gate. Retrieved April 28, 2016, from http://www.tutorialspoint.com/computer_logical_organization/logic_gates.htm

The OR gate gets its name from the use of the “OR” logical operator. Here, the output will be 1 (TRUE) if either or both the inputs are “TRUE”. If both inputs are “false,” then the output is “false.”

Logic diagram

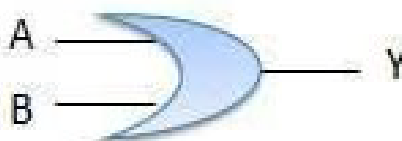

Truth Table

Inputs		outputs
A	B	A+B=Y
0	0	0
0	1	1
1	0	1
1	1	1

NOT Gate

Adapted from Basic gates and functions. Retrieved September 03, 2012, from http://www.slideshare.net/pong_sk1/basic-gates-and-functions and [Logic gates](#). Retrieved April 28, 2016, from http://www.tutorialspoint.com/computer_logical_organization/logic_gates.htm

A logical inverter, sometimes called a NOT gate to differentiate it from other types of electronic inverter devices, has only one input. It reverses the logic state.

Logic diagram

Truth Table

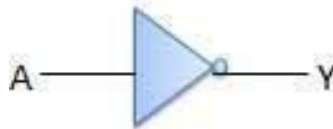

Figure 2.3- NOT Gate

INPUT	OUTPUT
A	Y (NOT A)
0	1
1	0

Table 2.5: NOT Gate truth table

Adapted from P. S. (n.d.). Basic gates and functions. Retrieved September 03, 2012, from http://www.slideshare.net/pong_sk1/basic-gates-and-functions and [Logic gates](#). Retrieved April 28, 2016, from http://www.tutorialspoint.com/computer_logical_organization/logic_gates.htm

NOR Gate

The NOR gate is a combination OR gate followed by an inverter. Its output is “true” if both inputs are “false.” Otherwise, the output is “false.”



Figure 2. 4: NOR Gate

Inputs		Output
A	B	$\overline{A+B}$
0	0	1
0	1	0
1	0	0
1	1	0

Truth Table

Logic gates Retrieved April 28, 2016, from http://www.tutorialspoint.com/computer_logical_organization/logic_gates.htm

XOR Gate

Adapted from P. S. (n.d.). Basic gates and functions. Retrieved September 03, 2012, from http://www.slideshare.net/pong_sk1/basic-gates-and-functions and [Logic gates](#). (n.d.). Retrieved April 28, 2016, from http://www.tutorialspoint.com/computer_logical_organization/logic_gates.htm

The XOR (exclusive-OR) gate acts in the same way as the logical “either/or.” The output is “true” if either, but not both, of the inputs are “true.” The output is “false” if both inputs are “false” or if both inputs are “true.” Another way of looking at this circuit is to observe that the output is 1 if the inputs are different, but 0 if the inputs are the same

Logic diagram

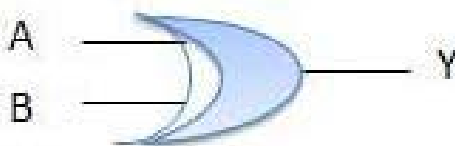

Figure: 2.5: XOR Gate

Truth Table

Inputs		Output
A	B	$A \oplus B$
0	0	1
0	1	0
1	0	0
1	1	1

Table: 2.7 :XOR Gate truth table

Adapted from Basic gates and functions. Retrieved September 03, 2012, from http://www.slideshare.net/pong_sk1/basic-gates-and-functions and [Logic gates](#) Retrieved April 28, 2016, from http://www.tutorialspoint.com/computer_logical_organization/logic_gates.htm

NAND Gate

This kind of gate works like the AND gate only that the AND gate must be followed by a NOT gate. The principle for this one is that the output is false if both the inputs are "TRUE", otherwise the output is "FALSE". Adapted from Basic gates and functions. Retrieved

September 03, 2012, from http://www.slideshare.net/pong_sk1/basic-gates-and-functions_and [Logic gates](#). Retrieved April 28, 2016, from http://www.tutorialspoint.com/computer_logical_organization/logic_gates.htm



Figure:2.6 NAND Gate

Truth table

Inputs		Output
A	B	NOT(A and B)
0	0	1
0	1	1
1	0	1
1	1	0

Table 2.8 NAND Gate table

Using combinations of logic gates, complex operations can be performed. In theory, there is no limit to the number of gates that can be arrayed together in a single device

- Available on: <http://www.ee.surrey.ac.uk/Projects/CAL/digital-logic/gatesfunc/TruthFrameSet.htm>
- <http://site.iugaza.edu.ps/amarasa/files/Lab-11.pdf>
- <http://studystuff9.blogspot.com/> and [Logic gates](http://www.tutorialspoint.com/computer_logical_organization/logic_gates.htm). Retrieved April 28, 2016, from http://www.tutorialspoint.com/computer_logical_organization/logic_gates.htm

Lab Work and Learning Activity 2

Learning activity details: Design and Construction of Logic gates- [Estimated Time 13 hours].

In this activity, you are to construct and give a logic circuit diagram for each of the following; You may wish to start by constructing truth tables for each first.

1. Supposing you are given the input below, what would be its logic gate? $(A + B)C$

Solution

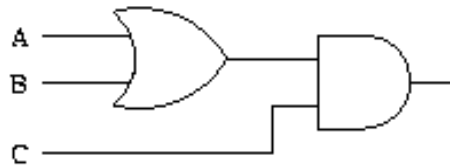

Logic gates. (n.d.). Retrieved April 28, 2016, from http://www.tutorialspoint.com/computer_logical_organization/logic_gates.htm

2. Construct a logic circuit for the input below

Solution

$$A + BC + \bar{D}$$

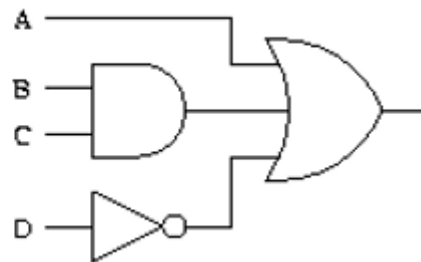

3. How would a logic circuit for the input below look like?

Solution

$$AB + \overline{AC}$$

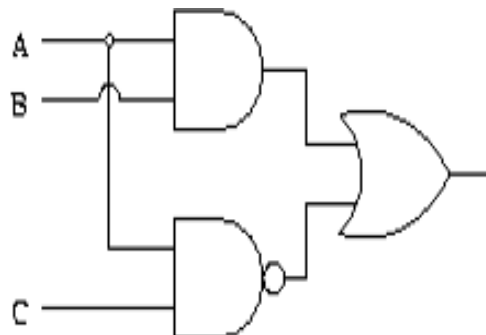

4. Construct a logic circuit for the input below

Solution

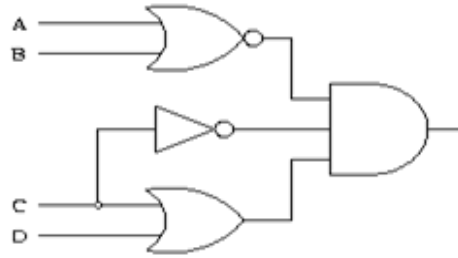

Learning Activity 3

Learning activities details : Construction of truth tables [Estimated 3 hours]

Consider the following statements. (adapted from Logic. (n.d.). Retrieved April 28, 2016, from http://college.cengage.com/mathematics/berresford/calculus_finite/2e/shared/logic/chapter-l.pdf)

Let X represent the statement “Peter ordered codfish,” and let Y represent the statement “Peter ordered ice cream.” Take it that $\sim Y$ means John did not order ice cream; $X \wedge Y$ John ordered codfish and ice cream (both); \vee represents either of them. Represent each sentence symbolically using X, Y, and logical connectives the following. Draw an equivalent truth table.

- Peter did not order ice cream.
- Peter ordered codfish or ice cream.
- Peter ordered codfish but not ice cream.
- If Peter did not order codfish, then he ordered ice cream.

Solution

- $\sim Y$
- $X \vee Y$
- $X \wedge \sim Y$
- $\sim X \rightarrow Y$

Truth Table

q	$\sim q$
1	0
0	1

2. Let X represent the statement “the yard is large,” and let Y represent “the house is small.” Express each symbolic statement as a sentence. Draw and equivalent truth table.

- $\sim X$ Answer: the yard is not small
- $\sim X \wedge Y$ Answer: The yard is not small same as the the house
- $X \wedge Y$ Answer: the yard is small and the house is small.

(adapted from Logic. (n.d.). Retrieved April 28, 2016, from http://college.cengage.com/mathematics/berresford/calculus_finite/2e/shared/logic/chapter-l.pdf)

Unit Assessment

1. Use 2's Complement to evaluate the following
 - a. $0111_2 - 1000_2$
 - b. Subtract 4 from 12
2. The output of an AND gate with three inputs, A, B, and C, is HIGH. What are the inputs?
3. If a 3-input NOR gate has eight input possibilities, how many of those possibilities will result in a HIGH output?
4. If a signal passing through a gate is inhibited by sending a LOW into one of the inputs, and the output is HIGH. What is the logic gate?
5. The logic gate that will have HIGH or "1" at its output when any one of its inputs is HIGH. What is the logic gate?

Grading Scheme

This assessment is worth 5 % of your total course mark as follows

Each question carries 1 %

Feedback

You should check if you got the following answers.

1. Use 2's Complement to evaluate the following

a. $0111_2 - 1000_2$ Answer 0001_2

b. Subtract 4 from 12 Answer 1000_2

2. The output of an AND gate with three inputs, A, B, and C, is HIGH. What are the inputs? Answers: A = 1, B = 1, C = 1

3. If a 3-input NOR gate has eight input possibilities, how many of those possibilities will result in a HIGH output?

Answer. 1

4. If a signal passing through a gate is inhibited by sending a LOW into one of the inputs, and the output is HIGH. What is the logic gate?

Answer. NAND Gate

5. The logic gate that will have HIGH or "1" at its output when any one of its inputs is HIGH. What is the logic gate?

Answer OR gate

Unit Summary

The boolean algebra is the basis of logic circuits. The truth tables are constructed based on the values of the input variables in the boolean expressions. You can now identify, describe and analyze the gate symbols for the Boolean operations AND, OR, NOT and XOR.

Unit Readings and Other Resources

The readings in this unit are to be found at course level readings and other resources.

1. <http://www.edupub.gov.lk/Administrator/English/10/ICT%20g-10%20E%20new%20syllbus/Chapter%203.pdf> Data Representation Methods in the Computer system
2. http://www.rapidtables.com/math/number/Numeral_system.htm Rapid tables reference and tools. (n.d.).
3. <http://www.ee.surrey.ac.uk/Projects/CAL/digital-logic/gatesfunc/index.html> #notgate: BasicGates and Functions
4. <http://www3.ntu.edu.sg/home/ehchua/programming/java/datarepresentation.html> - A Tutorial on Data Representation: Integers, Floating-point Numbers, and Characters
5. <http://www.ee.surrey.ac.uk/Projects/CAL/digital-logic/gatesfunc/index.html#notgate> : BasicGates and Functions
6. http://www.tutorialspoint.com/computer_logical_organization/logic_gates.htm- logic gates
7. http://college.cengage.com/mathematics/berresford/calculus_finite/2e/shared/logic/chapter-1.pdf - logic