



**CERTIFICATE IN
FASHION DESIGNING
SURFACE ORNAMENTATION
CFD-03**

Message for the Students

Dr. Babasaheb Ambedkar Open (University is the only state Open University, established by the Government of Gujarat by the Act No. 14 of 1994 passed by the Gujarat State Legislature; in the memory of the creator of Indian Constitution and Bharat Ratna Dr. Babasaheb Ambedkar. We Stand at the seventh position in terms of establishment of the Open Universities in the country. The University provides as many as 54 courses including various Certificate, Diploma, UG, PG as well as Doctoral to strengthen Higher Education across the state.



On the occasion of the birth anniversary of Babasaheb Ambedkar, the Gujarat government secured a quiet place with the latest convenience for University, and created a building with all the modern amenities named 'Jyotirmay' Parisar. The Board of Management of the University has greatly contributed to the making of the University and will continue to this by all the means.

Education is the perceived capital investment. Education can contribute more to improving the quality of the people. Here I remember the educational philosophy laid down by Shri Swami Vivekananda:

“We want the education by which the character is formed, strength of mind is increased, the intellect is expand and by which one can stand on one’s own feet”.

In order to provide students with qualitative, skill and life oriented education at their threshold. Dr. Babaasaheb Ambedkar Open University is dedicated to this very manifestation of education. The university is incessantly working to provide higher education to the wider mass across the state of Gujarat and prepare them to face day to day challenges and lead their lives with all the capacity for the upliftment of the society in general and the nation in particular.

The university following the core motto ‘स्वाध्यायः परमम् तपः’ does believe in offering enriched curriculum to the student. The university has come up with lucid material for the better understanding of the students in their concerned subject. With this, the university has widened scope for those students who are not able to continue with their education in regular/conventional mode. In every subject a dedicated term for Self Learning Material comprising of Programme advisory committee members, content writers and content and language reviewers has been formed to cater the needs of the students.

Matching with the pace of the digital world, the university has its own digital platform Omkar-e to provide education through ICT. Very soon, the University going to offer new online Certificate and Diploma programme on various subjects like Yoga, Naturopathy, and Indian Classical Dance etc. would be available as elective also.

With all these efforts, Dr. Babasaheb Ambedkar Open University is in the process of being core centre of Knowledge and Education and we invite you to join hands to this pious *Yajna* and bring the dreams of Dr. Babasaheb Ambedkar of Harmonious Society come true.



Prof. Ami Upadhyay
Vice Chancellor,
Dr. Babasaheb Ambedkar Open University,
Ahmedabad.

Editor

Prof. (Dr.) Ami Upadhyay
Vice Chancellor
Dr. Babasaheb Ambedkar Open University, Ahmedabad
Dr. Awa Shukla
Assistant Professor (Subject Head)/ Director (I/c) Student Services
Dr. Babasaheb Ambedkar Open University, Ahmedabad

Programme Advisory Committee

Prof. (Dr.) Ami Upadhyay
Vice Chancellor
Dr. Babasaheb Ambedkar Open University, Ahmedabad
Dr. Awa Shukla
Assistant Professor (Subject Head)/ Director (I/c) Student Services
Dr. Babasaheb Ambedkar Open University, Ahmedabad
Dr. Rajeshri Yadav
Prof. (CACDDM)
Government Girls College, Ahmedabad
Dr. Hemalata Patel
Prof. (Home-Science)
Mahila Home-Science College, Mahesana
Ms. Devyani Dhandhukiya
Fashion Designer & Freelancer, Ahmedabad

Reviewers

Dr. Rajeshri Yadav
Prof. (CACDDM)
Government Girls College, Ahmedabad
Dr. Hemalata Patel
Prof. (Home-Science)
Mahila Home-Science College, Mahesana

Content Writers

Ms. Devyani Dhandhukiya

Programme Coordinator

Dr. Awa Shukla
Director (I/c) Student Services
Dr. Babasaheb Ambedkar Open University, Ahmedabad

Publisher

Dr. Bhavin Trivedi
Registrar (I/c), Dr. Babasaheb Ambedkar Open University, Ahmedabad

Copyright © Dr. Babasaheb Ambedkar Open University – Ahmedabad. June 2020



This publication is made available under a Creative Commons

Attribution-NonCommercial-ShareAlike 4.0 International
(CC BY-NC-SA 4.0)

<https://creativecommons.org/licenses/by-nc-sa/4.0/>

ISBN-978-93-89456-73-8

All rights reserved. No part of this work may be reproduced in any form, by mimeograph or any other means without permission in writing from Dr. Babasaheb Ambedkar Open University, Ahmedabad. While all efforts have been made by editors to check accuracy of the content, the representation of facts, principles, descriptions and methods are that of the respective module writers. Views expressed in the publication are that of the authors, and do not necessarily reflect the views of Dr. Babasaheb Ambedkar Open University. All products and services mentioned are owned by their respective copyrights holders, and mere presentation in the publication does not mean endorsement by Dr. Babasaheb Ambedkar Open University. Every effort has been made to acknowledge and attribute all sources of information used in preparation of this learning material. Readers are requested to kindly notify missing attribution, if any.



Dr. Babsaheb Ambedkar Open University
(Established by Government of Gujarat)

CERTIFICATE IN FASHION
DESIGNING SURFACE ORNAMENTATION
CFD-03

Block

1

Unit 1

Importance of Surface Ornamentation in Fashion Design

Unit 2

Decorative Stitches I

Unit 3

Decorative Stitches II

Unit 4

Patchwork

Unit 5

Applique

Unit 6

Crochet

Unit 7

Tie-Dye

UNIT: 1

**IMPORTANCE OF SURFACE
ORNAMENTATION IN FASHION DESIGNING**

1.0 OBJECTIVES**1.1 INTRODUCTION****1.2 IMPORTANCE OF SURFACE ORNAMENTATIONS****1.3. CHECK YOUR PROGRESS****1.4 MULTIPLE CHOICE QUESTIONS****1.5 LET US SUM UP****1.6 KEYWORDS****1.7 SUGGESTED BOOKS****1.8 ANSWER**

1.0. OBJECTIVES

- To learn the importance of surface ornamentation.
- To gain knowledge about the scope of surface ornamentation on fashion and apparel products.
- To classify the techniques of surface ornamentation.

1.1 INTRODUCTION

Fabric ornamentation is decorations that are normally added to fabrics to make them more beautiful, Common materials which are used for this process include embroidery, batik, tie-dye, beads and buttons. In many ways, ornamentation is the ultimate tool of the decorator.

It can be seen with some degree of accuracy, as the heart and soul of the decorative world. To understand and accept ornamentation, is to understand and accept decoration. Picking up a Collins English dictionary, the easy definition of the word ornamentation is: “to make something more attractive, by adding decorations” or “to make a story more interesting by adding details, which may not be true” Collins Thesaurus makes an addition to the word ornamentation, by adding: decorate, enhance, adorn, dress, grace, deck, trim, dress up, enrich, garnish, ornament, gild,

Surface ornamentation is an important component of free-form, it’s a great way of bringing your personality, your style and skills to your work and putting your own stamp on your project.

To make an addition to, or to enhance the sum of, seems to be an integral part of human nature. We have always felt the need to embroider, using the word in its loosest term, whether that is through design or craft, or indeed through fact or fiction. In this we are as one species, as no matter what culture or era we think of, we have all used decoration to enhance and embellish most elements of the artificial world that has been created.

1.2 IMPORTANCE OF SURFACE ORNAMENTATIONS

1.2 1 Textile ornamentation

Textiles in particular have a long and full tradition of ornamentation. Additions to fabric can take the form of nearly anything, from the addition of pure stitching to other fabrics, beads, metals, wood, glass, precious stones and animal products. Ornamentation can also take many forms, with pattern work following the suggestion of nature, the geometrical abstract, fonts and lettering. It can be perceived as a subtlety, the changing of colour, line and texture, or it can be much bolder, using large-scale shapes and patterns. Whatever the technique or suggestion for composition, the end result is always nearly the same, to make something more than it was, to add decoration to enhance its attraction to the individual.

1.2.2 Ornamentation in the Decorative Arts

Ornamentation is by no means limited to textiles. Ceramics, glass, metal, wood in fact all the major and minor decorative arts, used for ornamentation are legitimate tool to enhance their results. It was also seen by successive generations as an integral addition to the skills base of the discipline, rather than as a filler or by-product of the main event.

This relatively intense and symbiotic human attraction to the decorative is something that Modernism, on the whole, failed to take into account. In many respects, Modernism saw one of its tasks as the declaring of war on the traditions of human nature and human decorative art, seeing decoration and pattern as the addition of extraneous ornamentation through dishonesty to the form and function of the product. To be fair this does have some merit, ornamentation can well be seen as a form of starting up, a disguise or distraction of the practical purpose of the product if you will, even to the point of the deflection of the truth. Anyone who has bought a frozen pizza in a box will know exactly what that is. Even the second definition of the Collins English dictionary as stated above, though being an applicable towards fiction and story-telling, does make the implication clear as far as at least a proportion of ornamentation is concerned: adding details which may not be true. Having said that, was it strictly necessary to have a near iconoclastic crusade against the world of ornamentation, decoration and pattern? Probably not.

A number of minimal Modernist enthusiasts had frankly disturbing ideas as to where they stood in the time frame of the decorative arts, compared to those who decorated.

Many of those ideas and analogies bordered on cultural bigotry with traditional decoration being seen by many, as belonging to a world of the non-sophisticated and the culturally backward. It is perhaps an unsavoury aspect of some of the 20th century theories on design and decoration,

theories which are often stripped of their more contentious aspects by today's world. In many respects, the iconoclastic approach the Modernists took to decoration had a mixed result, at least on the level of the removal of pattern

To define the term surface ornamentation as used on innovative fashion products, textile surface design is the art of changing the appearance of natural and synthetic surfaces by the application of traditional, stylized, digitized and illusionary techniques to decorate a product.

It is also the art of enhancing a textile surface structure by applying three-dimensional techniques, such as weaving, knitting, embroidery, lace, beading and embossing.

1.2.3 Ornamentations in Sewing and Crafts

In sewing and crafts, ornamentation is anything that adds design interest to the Piece. Designing the surface of the garment to make it more beautiful and attractive is known as Surface ornamentation or Embellishment. Surface ornamentation is a method of value addition to the fabric. It increases the value of the garment both by the appearance and by its price.

1.2.4 Significance of Surface ornamentations

In simple terms, one can define value addition as a means of enhancing the appearance and value of the garment. As we all know that fashion is a cycle and trends keep changing, at present people are going in for highly ornamented garments, not only for weddings, they are get into formals, party wear and so on. Ornamentation not just adds value for the garment, but also increases its price to a higher extent.

1.2.5 Fabric Decoration in India

India has long been known for fabric decoration using traditional weaving, dyeing and embroidery. Indian embroidery has become synonymous with traditional fabric ornamentation. Its origin dates back to ancient times. Embroidery has adorned almost everything in fabrics, from hand kerchiefs to quilts to wearable and home furnishings.

Be it a simple running stitch of Kantha or the satin and chain stitch of Kashmiri Kashida to the intricate Chikankari of Lucknow inspired from the Mughal era, they all depict the passion and life of the craftsmen of India.

Embroidery is just one of the many value addition techniques used. Other techniques are applique works, printing and dyeing techniques, crochet, braiding, bead work, painting and printing work and quilting.

Each of these methods has their own applications and value, which will be discussed in detail in this course. There is fascinating potential of the embellished and altered textile surface and form applied to the creation of fashion and fashion accessories.

With a large variety of techniques, applications and materials enabling you to create unique textile surfaces with rich and exotic textures, gorgeous colour and 3D, manipulated forms, there is an array of new and innovative techniques that can be made with exploration and experimentation.

Quick explorations with samples lead to the production of embellished surfaces enhanced with gilding, painting, stiffening, beading, padding, stuffing, wiring, collaging, folding, gathering, wrapping, fraying, and patch work, laminating and stitching. Surface ornamentation helps you translate

your design inspirations into a special, unique artwork of your own choice. It encompasses a mixture of techniques and applications.

1.2.6 Classification of Surface ornamentations Techniques

Design on a Surface is a completely open-ended classification for creativity that provides almost limitless opportunities for artistic expression. Textures and media may be presented in a new and unexpected way. The name "Surface Design" includes not only fibres, but other material too.

Textile Art

The names "textile art" or "textile creation and design" are too limited, to be able to describe its possibilities. Today, soft, sculpted cloth figures have become a recognizable art and craft form, encompassing, a wonderfully diverse range, of textile and art techniques.

Examples of textile and art techniques are: Fabric manipulation, Quilting or needle sculpture, Beading, Embroidery, Painting, Dyeing and printing, Knitting, Weaving, Crochet, Fashion or costume design, and all sorts of other textile ornamentations. Textile representations have been part of our social and cultural history for centuries. Few examples survive today, due to the perishable nature, of the materials used, and undoubtedly, the over-handling of the items. Those that do exist, provide insights into culture, fashion, fabrics and the economy of the times in which they were made. The creative power you possess, to transform a formless thought or vision, into a fully formed expression, and extension of yourself, using only a yard of fabric and a spool of thread is truly a creative gift, and is achievable by anyone with a little knowledge, some patience and a few basic skills.

1.2.7 Indian Market – Embroidery

Embroidery, till a decade ago, was largely in the unorganized sector. almost, 60% of the market was governed by the organized sector. Surat and Mumbai were the major embroidery centers in the country. Bareilly and Muradabad are known for beadwork. As the export market is getting more organized, more enterprises started export of embroidered articles. Leading company Aayee in Mumbai has a market in the range of Rs.400 – Rs.1500 a metre, for hand embroideries, and Rs.50 – Rs.100 a metre for machine embroideries.

Our exports are growing at the rate of 15 – 20% per annum. Garments with sequins and crochet laces (of Indian looks) are well received by foreign customers, and now, such works are being done on sleep wear too. Sequin and beadwork, Tie and die textiles too have a good market value.

1.3 CHECK YOUR PROGRESS

1. What is surface ornamentation?

2. Write a short note about textile ornamentation.

3. Write about role of surface ornamentation in sewing and crafts.

4. Classify techniques of surface ornamentation.

1.4 MULTIPLE CHOICE QUESTIONS

1. Fabric ornamentation is _____ that are normally added to fabrics to make them more beautiful,

- (A) Fabric (B) Dart
(B) Colour (D) Decorations

2. Design on a Surface is a completely _____-ended classification.

- (A) Open (B) Close
(C) Upper (D) Low

3. The name "_____ Design" includes not only fibres, but other material too.

- (A) Sculptures (B) Style
(C) Solar (D) Surface

4. Chikankari of _____ inspired from the Mughal era, they all depict the passion and life of the craftsmen of India.

- (A) Ahmedabad (B) Maharashtra
(C) Lucknow (D) Punjab

5. Surat and Mumbai are the major _____ centers in the country.

- (A) Game (B) Embroidery
(C) Technical (D) Dying

1.5 LET US SUM UP

In this unit, we learnt importance of surface ornamentation and importance of surface ornamentation in decorative art, in sewing & crafts, in textile art, in decorative art, and we also know about its value of it in Indian market too.

1.6 KEYWORDS

1. ORNAMENTATION: decorative elements added to something to enhance its appearance.
2. ACCURACY: to fact of being exact or correct.
3. ENHANCE: to improve something or to make something look better
4. GRACE: the ability to move in a smooth a controlled way.
5. DECK: one of the floors of a ship or bus or something.
6. ENRICH: to improve the quality, flavour of something.
7. COMPONENT: one of several parts of which something is made.
8. INTERGAL: necessary in order to make something complete.
9. SPACIE: a group of plants or animals that are all the same &that can breed together.
10. EMBLISH: to make something beautiful by adding decoration to it.
11. SUBTLELY: not loud, bright, and noticeable.
12. LEGITIMATE: reasonable or acceptable.
13. DISCIPLINE: to practice of training people to obey rules & behave well.
14. MODERNISM: Morden character or quality of thought, experience or technique.
15. EXTRANEIOUS: irrelevant or unrelated to the subject being dealt with.
16. DISGUISE: a thing that you wear to use to change your appearance o that nobody recognizes you,
17. DEFLECTION: to change direction after hitting something/somebody.
18. IMPLICATION: the effect that something will have on something else in the future.
19. ICONOCLASTIC: criticizing or attacking cherished beliefs or initiations.
20. CRUSADE: a fight for something that you believe to be good or against something that you believe to be bad.

1.7 SUGGESTED BOOKS

1. Complete Guide Of Textile Fabric By Shailaja D. Naik.
2. Indian Traditional Textiles
3. Traditional Textiles Of India

1.8 ANSWER

1. What is surface ornamentation?

Fabric ornamentation is decorations that are normally added to fabrics to make them more beautiful, Common materials which are used for this process include embroidery, batik, tie-dye, beads and buttons. In many ways, ornamentation is the ultimate tool of the decorator.

It can be seen with some degree of accuracy, as the heart and soul of the decorative world. To understand and accept ornamentation, is to understand and accept decoration. Picking up a Collins English dictionary, the easy definition of the word ornamentation is: “to make something more attractive, by adding decorations” or “to make a story more interesting by adding details, which may not be true” Collins Thesaurus makes an addition to the word ornamentation, by adding: decorate, enhance, adorn, dress, grace, deck, trim, dress up, enrich, garnish, ornament, gild,

Surface ornamentation is an important component of free-form, it’s a great way of bringing your personality, your style and skills to your work and putting your own stamp on your project.

To make an addition to, or to enhance the sum of, seems to be an integral part of human nature. We have always felt the need to embroider, using the word in its loosest term, whether that is through design or craft, or indeed through fact or fiction. In this we are as one species, as no matter what culture or era we think of, we have all used decoration to enhance and embellish most elements of the artificial world that has been created.

2. Write a short note about textile ornamentation.

Textiles in particular have a long and full tradition of ornamentation. Additions to fabric can take the form of nearly anything, from the addition of pure stitching to other fabrics, beads, metals, wood, glass, precious stones and animal products. Ornamentation can also take many forms, with pattern work following the suggestion of nature, the geometrical abstract, fonts and lettering. It can be perceived as a subtlety, the changing of colour, line and texture, or it can be much bolder, using large-scale shapes and patterns. Whatever the technique or suggestion for composition, the end result is always nearly the same, to make something more than it was, to add decoration to enhance its attraction to the individual.

3. Write about role of surface ornamentation in sewing and crafts.

In sewing and crafts, ornamentation is anything design interest to the Piece. Designing the surface of the garment to make it more beautiful and attractive is known as Surface ornamentation or Embellishment. Surface ornamentation is a method of value addition to the fabric. It increases the value of the garment both by the appearance and by its price.

4. Classify techniques of surface ornamentation.

Design on a Surface is a completely open-ended classification, for creativity that provides, almost limitless opportunities for artistic expression. A form of art that is not hindered by preconceived ideas, stereotypes or pigeon-holing. Textures and media may be presented in a new and unexpected way. The name "Surface Design" includes not only fibres, but other material too.

Textile Art

The names "textile art" or "textile creation and design" are too limited, to be able to describe its possibilities. Today, soft, sculpted cloth figures have become a recognizable art and craft form, encompassing, a wonderfully diverse range, of textile and art techniques.

Examples of textile and art techniques are: Fabric manipulation, Quilting or needle sculpture, Beading, Embroidery, Painting, Dyeing and printing, Knitting, Weaving, Crochet, Fashion or costume design, and all sorts of other textile ornamentations. Textile representations have been part of our social and cultural history for centuries. Few examples survive today, due to the perishable nature of the materials used, and undoubtedly, the over-handling of the items. Those that do exist, provide insights into culture, fashion, fabrics and the economy of the times in which they were made. The creative power you possess, to transform a formless thought or vision, into a fully formed expression, and extension of yourself, using only a yard of fabric and a spool of thread is truly a creative gift, and is achievable by anyone with a little knowledge, some patience and a few basic skills.

MCQ ANSWER

- 1. Decorations**
- 2. Open**
- 3. Surface**
- 4. Lucknow**
- 5. Embroidery**

UNIT: 2

BASIC DECORATIVE STITCHES PART-1

2.0 OBJECTIVES**2.1 INTRODUCTION****2.2 TYPES OF DESIGN****2.3 TRACING MATERIALS AND METHOD****2.4. CHECK YOUR PROGRESS I****2.5 TOOLS AND MATERIALS FOR DECORATIVE STITCHES****2.6 CHECK YOUR PROGRESS II****2.7 MULTIPLE CHOICE QUESTIONS****2.8 LET US SUM UP****2.9 KEYWORDS****2.10 SUGGESTED BOOKS****2.11 ANSWER**

2.0 OBJECTIVES

- To gain knowledge about decorative stitches
- To learn Uses of tools and materials of decorative stitches
- To learn methods of design tracing

2.1 INTRODUCTION

Decorative stitches make garments look pretty with colourful pattern. It is a creative

portion of thread art. Decorative stitch is hand work embroidery which is done with the help of threads and needle. Embroidery gives a rich look in some variety of clothes such as children wear, women wear, or other furnishing like bed sheets, pillow covers, table cloth, wall hangings, etc.

2.2 TYPES OF DESIGN

The very first step of making decorative stitch is selecting the design. Design inspiration in embroidery has mostly been from nature and flowers, butterfly, birds, elephant, human etc. Some varieties of designs as follows;

Design made from intellectual or non-representational idea is Abstract design.

2.2.4. MYTHIC



(fig.4. mythic)

Designs inspired from mythological story or mythology symbols are called mythic designs.

2.2.5. ETHNIC

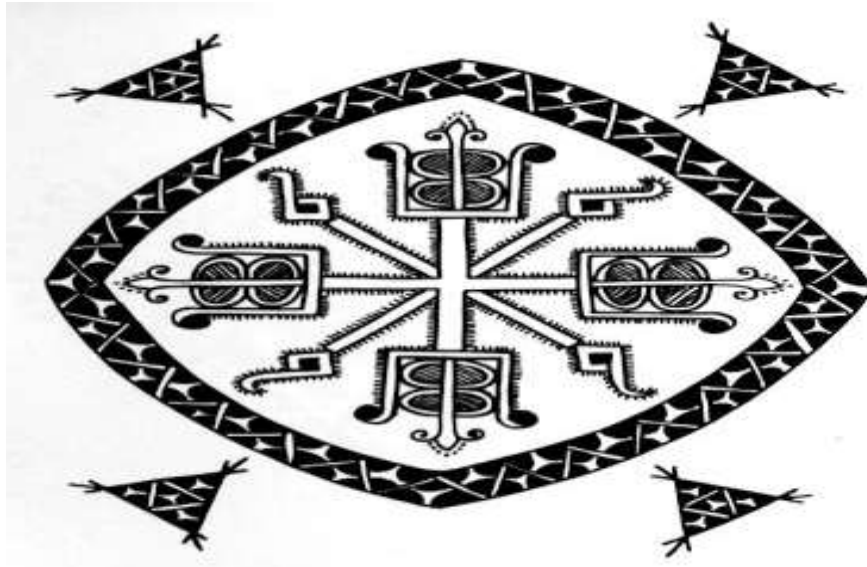

(fig..5. ethnic)

Designs made from any typical characters of any tribe and tribal symbols are called ethnic designs.

2.3 TRACING MATERIALS AND METHOD

After selecting the design, a very second step of doing embroidery is tracing the selected design on fabric. Some tools and materials are required for tracing such as design on paper, Tracing paper, Pen, Carbon paper, Iron

, Piece of glass and light box/sunlight, Needle, Chalk powder ,Kerosene oil, Stencils.etc.

Person with good drawing skill can draw design directly on the fabric by hand.

2.3.1 Transferring design by heat



(fig.6. transferring design by heat)

A very easy and most common way to transfer design is by using heat. The first step to trace it is, copy the design on paper, on fabric, a sheet of design, an iron and a pressing cloth is needed. To transfer the design on the fabric, put the fabric face down and trace the sheet on it. Then heat it with an iron for some time. The design will transfer to the garment in a few seconds.

2.3.2. Transferring design by light



(fig.7. transferring design by light)

With a view to transfer the design, daylight and light box can be used. To use daylight, find window with full of sunlight and tape the design on to the glass of the window and put the fabric over it as the sunlight shines on the fabric. Design can easily be copied. Other method is a light box. In this method the design is put on the glass top and fabric attached over it. The light will be expose in area of design so that it can be traced to the fabric.

2.3.3 Transferring design by carbon paper



(fig.8. transferring design by carbon paper)

The easiest technique of tracing design is by using carbon paper. Carbon papers are available in craft stores with different colours. In this method first put the coloured side of the paper on the face of the fabric, and then put the design paper on the top of the carbon paper. After draw design with a pointed pencil. Special care is required while tracing the design, or else the carbon will make spots on the fabric. The fabric is placed on a hard surface; otherwise the design will not press hard on the carbon paper; else the colour from the carbon paper itself may get transferred on to the fabric, which might be hard to detach.

2.3.4. Transferring design by stencils



(fig.9. transferring design by stencils)

A stencil is a form of cut-out. Stencils are available with different sizes and designs in the craft store. Stencils are made of metal, plastic, thick paper, etc. First, select the stencil for the trace design and put it on the right side of fabric. Then, use a pencil to trace the design in the cut-out part of the stencil.

2.4. CHECK YOUR PROGRESS I

1. Write a definition of decorative stitch.

2. Write any 3 types of design for decorative stitch.

2.5 TOOLS AND MATERIALS FOR DECORATIVE STITCHES

2.5.1. NEEDLE THREADER



(fig.10. needle threader)

Needle threader is a wire loop. Needle threader also called eye saver. It is useful for those who have difficulty in threading needles.

2.5.2. EMBROIDERY FRAME



(fig.11. embroidery frame)

Frame is used for holding the embroidery portion and tight it while doing embroidery. A frame is a set of two rings and each ring fits inside each other, the fabric get fixed between them. The ring frame is most commonly used for giving the embroidery look pretty. Frames are made of wood, plastic and metal and frames sizes are mostly ranging from 7.5–30 cm on small designs. The frame has a nut and a bolt for tightening of the material.

2.5.3. SEAM RIPPER



(fig.12. seam ripper)

Seam ripper is used for unsew the wrong stitches.

2.5.4. THIMBLE



(fig.13. thimble)

Thimble is used to protect the fingers from getting pierced during embroidery. Thimbles are made of Metal, rubber and plastic. The embroiderer must take care of his/her hands and use thimble while doing hand embroidery. Mostly, thimble is worn in the middle finger. Thimble is used to push the needle to the fabric without harming the finger.

2.5.5. FABRICS

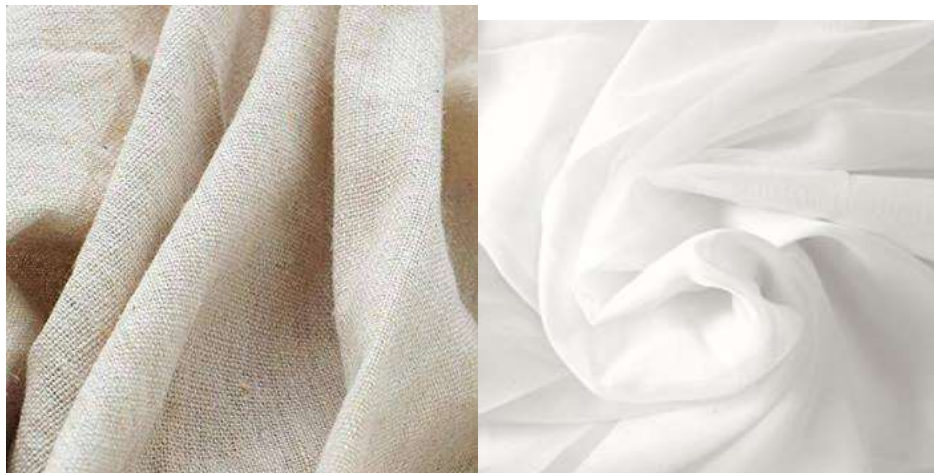

(fig.14. fabric)

- Linen fabric is made from natural fibres. Linen is soft and strong textured. Linen is used for making embroidery in Kurtis, Kurtas, and children's wear.
- Cotton is also natural fibre; it is soft and absorbent. Cotton keeps the body cool in summers. Decorative stitches look pretty in cotton fabric garments such as kurti, lehenga-choli, saree, suit, and children's clothes.
- Crepe is used for making flowing costume because crepe drapes very well. Crepe fabric made from different material like chiffon, cotton, and rayon, fur, silk and original leather, blended silk, crepe, linen, etc.
- Satin is a smooth and shiny material. Satin has a lot of shine which makes it suitable for making garments such as evening wear, bridal wear and party wear.
- Silk has a good strength, lustre and it makes silk look more attractive. Silk is the longest fibre of all. "Silk is one of the most popular fabrics for designer party wear because of its rich look". The embroidery on silk fabric is done with silk threads mostly.

2.5.6. DIFFERENT TYPES OF NEEDLE

1. Crewel needle



(fig.15. crewel needle)

Crewel is the basic needle used for hand embroidery. Crewel needle is known as embroidery needles. It has long slender eye, it has similar look as sewing needle in shape. The long eye helps inserting embroidery threads easily. The sharp tip helps the needle pierce even tight fabrics more easily. Crewel needles come in different sizes but the most popular sizes are size 7 and 9.

2. Tapestry needle



(fig.16. tapestry needle)

Tapestry needle has round point and a large eye; because of that it is easily inserted to the fabric without piercing it. therefore these needles are useful

in counted thread work such as cross stitch, pulled and drawn thread work, and lacing on composite stitches. It is very useful for wools, matte weave fabrics. It has a shorter shaft compare to a crewel needle but it has a longer eye, which is larger than the shaft. Tapestry needles are available in different sizes mainly from 13 to 28, with 13 being the largest and 28 being very fine.

3. Milliner needle



(fig.17. milliner needle)

“Milliner needle is also called a straw needle”. The milliner needle has a short round Eye and very long shaft and a sharp tip. The eye and the shaft on Needle are the same, which makes these needles for working on any wrapped embroidery such as bullion knot, French knots, etc. They are also used in fancy stitches.

4. Sharp needle



(fig.18. sharp needle)

Sharp needle has a small Eye. It is used for hand work embroidery.

2.5.7. DIFFERENT TYPES OF THREAD

1. Pearl cotton

Pearl cotton thread is used for decorative stitch. It is a single ply embroidery thread. Pearl cotton threads are available with differing thickness, colour and shade. The higher the number, the thicker the thread.



(fig.19. pearl cotton)

2. Metallic threads

Metallic thread is used for adding shine and glamour looks in embroidery work. Threads are available in sewing stores. It is available in different colours like gold, silver, copper etc. Metallic threads need less care.

3. Satin threads



(fig.20. satin thread)

Satin thread is used for to give a brighter look in the embroidery.

4. Wool threads



(fig.21.. wool threads)

Wool thread is used in some special embroidery where a woollen look is required in the embroidery. Wool threads are available in different weights and colours.

2.6 CHECK YOUR PROGRESS II

3. Write a short note about method of transferring design.

4. Explain embroidery frame.

2.7 MULTIPLE CHOICE QUESTIONS

- _____ is decorative portion of thread art.
(A) Decorative stitch (B) Stencil
(C) Thimble (D) Butterfly
- _____ is used for tighten the fabric during embroidery.
(A) Kerosene oil (B) Embroidery frame
(C) Pen (D) Design paper
- _____ is tracing tool of decorative stitch.
(A) Scissor (B) Thread
(C) Carbon paper (D) Needle threader
- _____ tool is used for unsew the stitches.
(A) Iron (B) Heat
(C) Seam ripper (D) Thimble
- _____ material is most popular for designer party wear.
(A) Silk (B) Poplin
(C) Cotton (D) Jute

2.8 LET US SUM UP

In this unit, we learnt about creating hand embroidery on different types of fabrics needs skill to select the accessories, backing, threads, backing material etc. to produce a good quality design. The designer should be familiar with basic embroidery techniques which will be suitable for fabrics. Embroidery design should be selected based on the type of fabric used. Then the type of threads, accessories to be used and the method to stitch should be planned to avoid flaws after stitching. Some fabrics like crepe, chiffon, georgette, knitted, velvet etc. sag while stitching. Hence a stabilizer should be used to keep the fabric stable while stitching. Light weight fabrics are embroidered with light and airy designs, solid fills may be avoided. Pile fabrics should be sandwiched between two stabilizers to avoid wrinkles on the fabric.

2.9 KEYWORDS

1. Decorative- embellish, beautifying, garnishing, adorning
2. Embroidery- embellishment, Ornamentation, Needlecraft, Sewing
3. Intellectual –Thinker, Brain, Scholar, learned person
4. Mythic- Legendary, Whimsical, Fanciful
5. Stencil- piece of cut work, sheet of material with carved design
6. crewel- a thin needle use for embroidery
7. Tapestry- needle name which is use for making stitch
8. Milliner- name of embroidery needle
9. Chenille- name of embroidery needle
10. Seam- join, stitching, junction, closer, line
11. Ply- layer, thickness, sheet

2.10 SUGGESTED BOOKS

1. Indian Embroideries By John Irwin & Margaret Hall
 2. Complete Guide To Needlework Reader's Digest
 3. Traditional Indian Textiles
 4. National Handicrafts And Handloom India
- { Note: Figures Are Adapted From Suggested Book List And Source Of Non-Copyrighted Materials }

2.11 ANSWER

1. Write a definition of decorative stitch.

Decorative stitch is a creative portion of thread art. It is hard work embroidery done with the help of threads and needle.

2. Write any 3 types of design of decorative stitch.

these are the main 3 designs uses for decorative stitches.

1. Natural-Design inspired from nature, like birds, animals, human figures, scenery, etc. are called natural designs.
2. Geometric- Any designs made of geometric shapes, like Simple Square, triangle, circle, rectangle, etc. are called geometric design.
3. Mythic- Any designs inspired from mythological story, or mythology symbols are called mythic design.

3. Write a short note about method of transferring design.

There are many techniques to transfer design on fabric. Embroiderer with good drawing skill can trace the design by hand on fabric and some other methods are:

1. Transferring design by heat-A very easy and most common way to transfer design is by using heat. First step to trace it, copy the design on paper, to trace it on fabric a sheet of design, an iron and a pressing cloth is needed. To transfer the design on the fabric, put the fabric face down and trace sheet on it. Then heat it with an iron for some time. The design will transfer to the garment in a few seconds.
2. Transferring design by carbon paper-The easiest technique of tracing design is by using carbon paper. Carbon papers are available in craft stores with different colours. In this method first Put the coloured side of the paper on the face of the fabric, and then put the design paper on the top of the carbon paper. After it, draw design with a pointed pencil. Special Care requires tracing the design, or else the carbon will make spots on the fabric.
3. Transferring design by stencil-A stencil is a form of cut-out. Stencils are available with different sizes and designs in the craft store. Stencils are made of metal, plastic, thick paper, etc. First, select the stencil for the trace design and put it on the right side of fabric. Then, use a pencil to trace the design in the cut-out part of the stencil.

4. Explain embroidery frame

Frame is used for holding the embroidery portion and tight it while doing embroidery. A frame is a set of two rings and each ring fits inside each other, the fabric fixed between them. The ring frame is used most commonly. It is used for giving the embroidery look pretty, clear. Frames are made of wood, plastic or metal and frames sizes are mostly ranging from 7.5–30 cm on small designs. The frame has a nut and a bolt for tightening of the material

MCQ ANSWER

- 1. Decorative Stitch**
- 2. Embroidery Frame**
- 3. Carbon Paper**
- 4. Seam Ripper**
- 5. Silk**

UNIT: 3

BASIC DECORATIVE STITCHES PART-II

3.0 OBJECTIVES**3.1 INTRODUCTION****3.2 BASIC DECORATIVE FLAT STITCHES****3.2.1. BACK STITCH****3.2.2. STEM STITCH****3.2.3. CROSS STITCH****3.2.4. FISHBON STITCH****3.2.5. SATIN STITCH****3.3. CHECK YOUR PROGRESS I****3.4 BASIC DECORATIVE LOOP STITCHES****3.5.1. CHAIN STITCH****3.5.2. LAZY DAISY STITCH****3.5.3. BLANKET STITCH****3.5.4. BUTTONHALL STITCH****3.5.5. FEATHER STITCH****3.5 CHECK YOUR PROGRESS II****3.6 MULTIPLE CHOICE QUESTIONS****3.7 LET US SUM UP****3.8 KEYWORDS****3.9 SUGGESTED BOOKS****3.10 ANSWER**

3.0 OBJECTIVES

- To gain knowledge about flat stitches and loop stitches.
- To learn method of basic flat stitches.
- To learn method of basic loop stitches.

3.1 INTRODUCTION

Some basic steps required to be followed while doing any kind of embroidery...

- confirm the embroiderer's hands are clean and washed so as not to leave spots on the embroidery work.

- The fabric of the traced design should be properly fixed in the embroidery frame. Fix it in the centre of the frame, and fix the fabric between the two rings of the frame and tighten with the screw as per requirement.
- Take all tools required for embroidery.
- Pull the thread on the upper side of the fabric from the back side of the fabric at the beginning point of the design. Fix end of the thread with very small knot, or hiding the end with the knot on the back side of the fabric.

3.2 BASIC DECORATIVE FLAT STITCHES

Flat stitches are made without looping the thread. “Flat stitches are known as straight stitches.” These stitches are mostly used for straight or curved outlines and sometimes used for filling also, depending on the design.

3.2.1 BACK STITCH

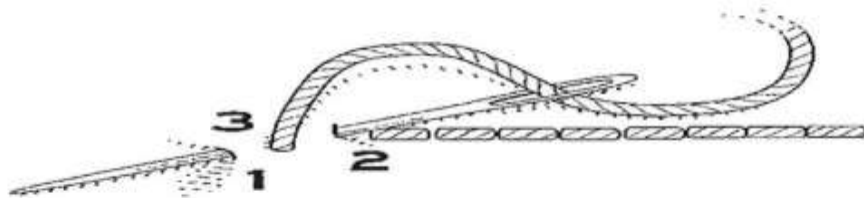

(fig.1. back stitch)

“Back stitch is taken from the backside of the needle and is thus called the back stitch.” There are no spaces between the back stitches. The embroidery is done from right to left. Be careful with stitches; the shape gets spoiled if the stitches overlap one another. Back stitch Embroidery looks flat and painted.

Follow the steps for making a back stitch.

1. Move a needle step backward and after it, take a step forward along the stitch line.
2. Bring the needle out at 1. Insert at 2 and remove at 3; distance between 3-1 and 1-2 should be equal. Repeat it for the next stitch.
3. Continue in a similar method and keep the length of the back stitches consistent.
4. Make a loop and pull the thread from the loop to end the stitch on the opposite side of the fabric.

3.2.2 STEM STITCH

Stem stitch is the easiest embroidery stitch. The complete work will look like a thin line on the front side, and at the back side it will look like a back stitch. The stem stitch is used for small designs on baby frocks and embroidered sari borders.

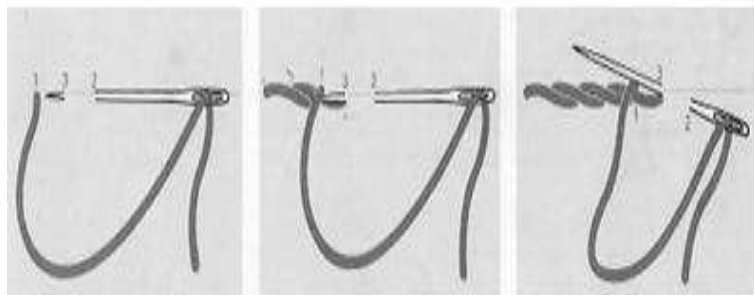

(fig.2. stem stitch)

Follow the steps for making the stem stitch.

1. Start at some distance and exit a half stitch length in reverse.
2. Maintain the length of the stitches equal.
3. The thread should be kept either on the left side or on the right side. Till the design is finished.
4. Continue in this way, keeping the stitches even in length.
5. Make a loop and pull the thread from the loop to end the stitch on the opposite side of the fabric.

3.2.3. CROSS STITCH

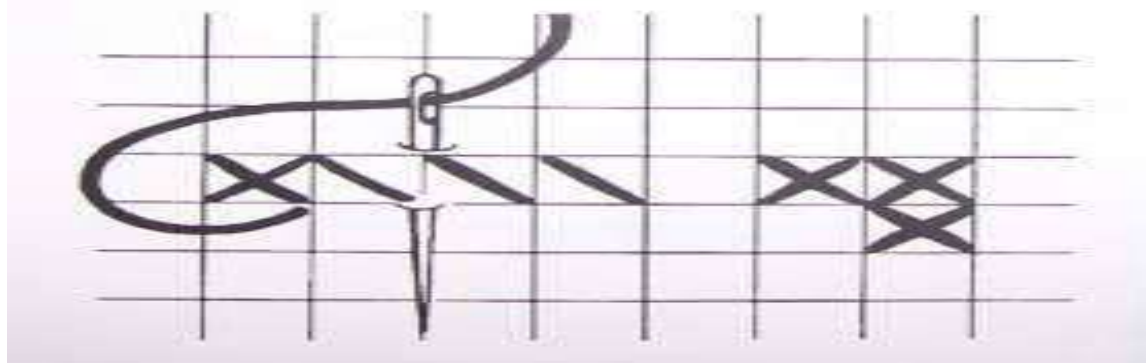

(fig.3. cross stitch)

Cross stitch is formed by two crossing. In this, a single stitch is taken first diagonally and then in another to cross the first at right angles. These crosses are mostly used in letters and numerals, geometrical designs, etc. A tapestry needle is used for this stitch. The most suitable fabric for a cross stitch is an even weaves fabric, khadi, jute. The cross stitch is used for embroidering saree borders, dresses, including that of children wear.

Follow the steps for making a cross stitch:

1. Pull the needle upwards and take diagonally cross stitches from the left to the right. Repeat the same from the right to the left to make the cross.
2. Continue in this way, the whole cross stitch design will be ready.
- 3 Make a loop and pull the thread from the loop to end the stitch on the opposite side of the fabric.

3.2.4. FISHBONE STITCH

“This stitch looks like a backbone of fish, so it is called fishbone stitch”. This is a type of flat stitch, which is suitable for making leaves or feathers. The line of the leaf is used as the centre and the stitches are taken alternately to its left and right. Two shades of the same colour are used in the design to make it more attractive. The fishbone stitch is used to embroider children’s garments such as bibs, frocks, yokes, etc.

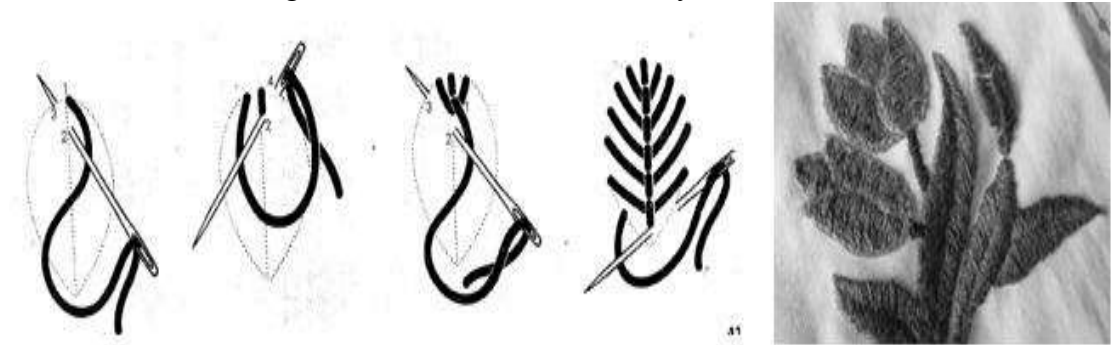

(fig.4. Fishbone stitch)

Follow the steps for making a fishbone stitch:

1. Start from the upper part of the line of the leaf, of the flower or according to the design.
2. Pull the needle from the backside to the front side and make a small stitch.
3. Now take one stitch to the right of the line upward from below.
5. Continue in the same way; take a stitch to the left of the line from the upward to the downward way.
6. Then pull out the needle from the left side of the line upwards.
7. Then, insert the needle to the right side of the line and continue embroidering.
8. Make a loop and pull the thread from the loop to end the stitch on the opposite side of the fabric.

3.2.5 SATIN STITCH

Satin stitch is made by working parallel stitches close together to cover the whole design, from the front and back side of the fabric. Satin stitch looks similar on both the sides of the fabric. Narrow and small-sized floral designs are mainly suitable for this stitch.

It is used on, bags, pillow covers, children’s garments, saris, etc.



(fig.5. satin stitch)

Following the general steps for making fishbone stitch;

1. Pull the needle from below, upwards, at the beginning of the design.

2. Insert the needle from above, downwards, at the other end of the line of the design.
3. Repeat the same method. Make the stitches close to one another by pulling the thread gently.
4. Take care that the thread does not overlap at curves.
7. Make a loop and pull the thread from the loop to end the stitch on the opposite side of the fabric

3.3. CHECK YOUR PROGRESS I

1. Explain back stitch.

2. Write a short note on satin stitch.

3.4 BASIC DECORATIVE LOOP STITCHES

Loop stitch is a kind of stitch in which loops are structured from the thread. Chain stitch is the most common type of loop stitch. Some other loop stitches are buttonhole stitch, blanket stitch, Lazy daisy, Feathers etc.

3.4.1. CHAIN STITCH

Chain stitches are used mostly to straight lines. But it can be used to embroider floral designs. While making chain stitch, the distance between the two stitches should be kept equal, the stitches should be kept even in length. They should never be drawn very tight; because that destroys the effect of their being linked in a chain. The chain stitch is used to embroider adult and children's garments. It is also a very common stitch for embroidering home furnishing items, etc.

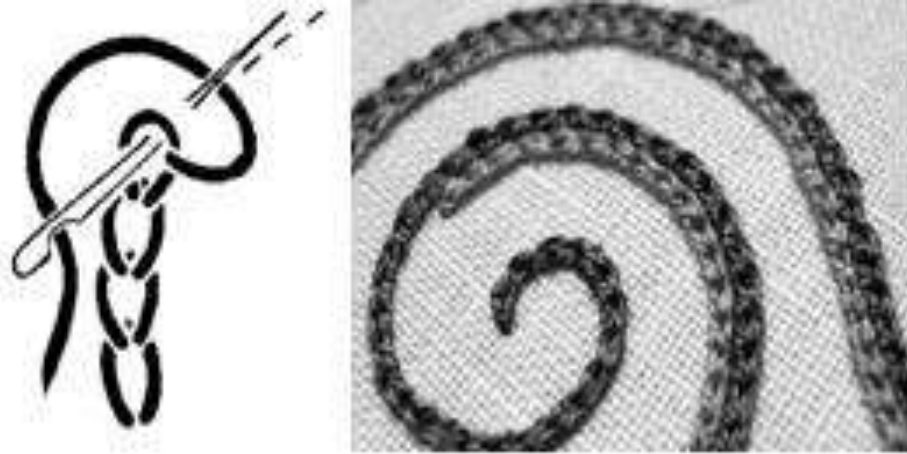

(fig.6. chain stitch)

Follow the steps for making a chain stitch:

1. To make a broad outline, the needle is passes across in a slanting way with loop thread under the needle.
2. Bring the thread out at the beginning of the line, hold the thread down with the left thumb while the needle is reinserted into the same spot and brought out again a short distance away. The needle is inserted back into the same hole and taken out at some distance above it.
3. The working thread is carried under the needle point.
4. Now, pull the needle very gently, so the chain loop is made.
5. Carry out the next stitch the same way, always inserting the needle into the hole made by the emerging thread. Continue in this way for the entire line or the design.
6. Work a chain stitch holding the thread which is being stitched firmly with the thumb. Adjust the loose thread and then adjust the chain stitch just made.
7. Make a loop and pull the thread from the loop to end the stitch on the opposite side of the fabric.

3.4.2. LAZY-DAISY

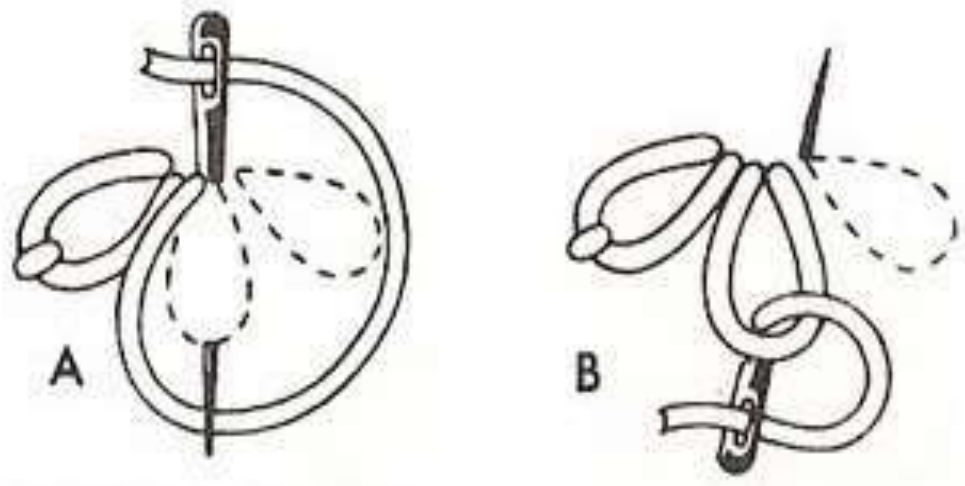

(fig.7. lazy-daisy)

This stitch is mostly used to embroider small petals and leaves. It is a small loop stitch. The lazy-daisy stitch is a variation of the chain stitch.

Follow the steps for making the lazy-daisy stitch:

1. Bring out the needle from below, upwards, at the base of the petal or the flower.
2. The needle is inserted back into the same hole and taken out at some distance above it. Carry the thread under the needle point.
3. Press the loop thread firmly under the thumb and pull out the needle gently. Insert the needle just over a chain loop.
4. To avoid twist in the thread, take out the needle from the nearest petal.
5. Proper shape and distance should be maintained while embroidering small petals of a flower or leaves.
6. Make a loop and pull the thread from the loop to end the stitch on the opposite side of the fabric.

3.4.3 BLANKET STITCH

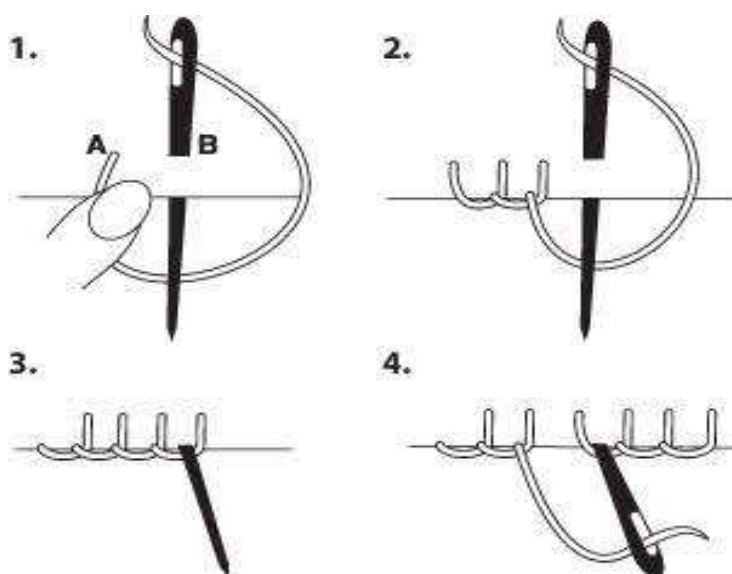

(fig.8. blanket stitch)

Blanket is similar to the buttonhole stitch and is mainly used to finish the blanket's edges. It is one of the simplest ways of decorating a garment's hem or edge. This stitch can be worked in straight or diagonal line.

Follow the steps for making a blanket stitch:

1. Bring the needle slant to the left for the first stitch and then insert it in slant in the same place for the right.
2. Two rows of blanket stitch, one straight and one slanting are worked to get a coloured binding on the edge of the fabric.
3. The straight stitches are only half the width of the binding.
4. Make a loop and pull the thread from the loop to end the stitch on the opposite side of the fabric.

3.4.4 BUTTONHOLE STITCH

“This stitch is used to finish buttonholes; thus, the name ‘buttonholes stitch’”. This stitch is to create an outline, finish the edges or attach applique. It is also used for attaching mirrors in embroidery patterns. These stitches are placed very close together to form a firm edge. At times, this stitch is used in the centre of a motif. The needle enters the same hole in the centre each time, making a hole in the centre while the wheel around it is

filled completely. The buttonhole stitch is used for outlining and attaching mirrors in embroidery, for example, most of the mirror work in Gujarat and Rajasthan uses this stitch. It is used to make the corners of table covers, bed sheets, sofa covers, chair covers, saree borders, etc

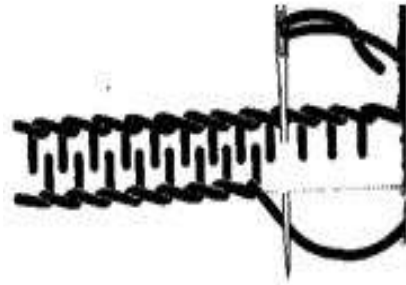

(fig.9. buttonhole stitch)

Follow the steps for making the buttonhole stitch:

1. Bring the needle out from below upwards, on the design line.
2. Base on the width of the stitch, insert the needle at one edge and take out from the other.
3. Before pulling the needle through the fabric, carry the thread under the needle point.
4. Embroider carefully to keep the width of the stitch even and work all the stitches very close together to keep the continuity.
5. In case of groups in the buttonhole stitch, even space should be maintained after each group.
6. Make a loop and pull the thread from the loop toned the stitch on the opposite side of the fabric.

3.4.5 FEATHER STITCH

Feather stitch is used in double line and floral designs. In the double line designs, the stitches are taken with some gaps in between. In the floral designs, the stitches are taken close to each other as well as small in size. In this stitch, each loop is formed first to the right hand side and then on the left hand side, All stitches should follow the same direction and should be equally spaced. This stitch is mostly used in women's wear like kurties, dresses and saris, etc.

(fig.10.feather stitch)

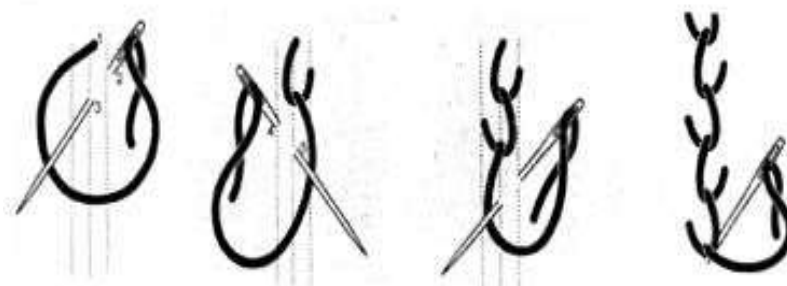

Follow the steps for making a feather stitch:

1. Bring the needle from the backside to the front side on the line of the design.
2. Work stitches from the top to the bottom.
3. Every time the needle is pulled very gently, press the stitch under the thumb.
4. Because of the back-and-front movement of the needle, care should be taken to keep the stitches even on both the sides of the central line.
6. Make a loop and pull the thread from the loop to end the stitch on the opposite side of the fabric.

3.5 CHECK YOUR PROGRESS II

3 .Explain Buttonhall Stitch.

4. Write A Short Note About Feather Stitch.

3.6 MULTIPLE CHOICE QUESTIONS

1. Which stitches are made without looping the thread?

(A) flat stitches	(B) chain stitch
(C) loop stitches	(D) buttonhole

2. Which stitches are made with looping the thread?

(A) fishbone	(B) stem stitch
(C) backstitch	(D) loop stitches

3. Fabric tightens between the two rings of the frame with _____ as per requirement.

(A) pen	(B) needle
(C) screw	(D) thread

4. Back stitch is taken from the _____ side of the needle, so it is called the back stitch.

(A) front side	(B) back side
----------------	---------------

(C) right side

(D) centre side

5. Lazy dazy is _____

(A) flat stiches

(B) loop stitches

(C) (A) or (B) both

(D) none of these

3.7 LET US SUM UP

In this unit, we learnt hand embroidery uses a combination of stitches. There are different types of stitches and variations of the basic stitches like straight, back, feather, buttonhole, stitches etc. Each stitch has its own identity and style. Few stitches can be used as outline and others as filling. Many patterns can be created using the combination of these stitches on hand kerchiefs, saree, dress materials, bed sheets and covers, furnishing materials etc.

3.8 KEYWORDS

1. Form: Shape, Structure, Formation, Round
2. Overlap: Flap, Overlay, Fold Over, Extend Along
3. Reverse: Other Side, Wrong Side, Backside
4. Backward: In Reverse, Back To Front
5. Forward: Ahead, Leading, Onwards
6. Consistent: Dependable, Same, Steady, And Persistent
7. Loop: Shape Created By a Curve That Bends Round And Cross Itself, Bend
8. Flat: Having a Level Surface, Level
9. Towards: Against, Approaching, Nearing, Almost
10. Progress: Growth, Evolution, Headway, Hike
11. Angles: Corner, Edge, Point, Turn
12. Rows: Sequences, Series, Line, Chain
13. Parallel: Coordinate, Aligned, Side By Side
14. Narrow: Confident, Restricted, Limited, And Small
15. SPIRALS: Circling, Rolled, Radial, Winding
16. SLANT: Angle, Slope, Leaning, Declination

3.9 SUGGESTED BOOKS

1. Indian Embroideries By John Irwin & Margaret Hall
 2. Complete Guide To Needlework Reader's Digest
 3. Traditional Indian Textiles
 4. National Handicrafts And Handloom India
- { Note: Figures Are Adapted From Suggested Book List And Source Of Non-Copyrighted Materials }

3.10 ANSWER

1. EXPLAIN BACK STITCH.

“Back stitch is taken from the backside of the needle and is thus called the back stitch.” There are no spaces between the back stitches. The

embroidery is done from right to left. be careful with stitches; the shape gets spoiled if the stitches overlap one another. Back stitch

Embroidery looks flat and painted.

Follow the steps for making a back stitch.

1. Move a needle step backward and after it take a step forward along the stitch line.
2. Bring the needle out at 1. Insert at 2 and remove at 3; distance between 3-1 and 1-2 should be equal. Repeat it for the next stitch.
3. Continue in a similar method and keep the length of the back stitches consistent.
4. Make a loop and pull the thread from the loop to end the stitch on the opposite side of the fabric.

2. WRITE A SHORT NOTE ABOUT SATIN STITCH.

Satin stitch is made by working parallel stitches close together to cover the whole design, from the front and back side of the fabric. Satin stitch looks similar on both the sides of the fabric. Narrow and small-sized floral designs are mainly suitable for this stitch.

It is use on, bags, pillow covers, children's garments, sarees, etc.

Following the general steps for making fishbone stitch

1. Pull the needle from below, upwards, at the beginning of the design.
2. Insert the needle from above, downwards, at the other end of the line of the design.
3. Repeat the same method. Make the stitches close to one another by pulling the thread gently.
4. Take care that the thread does not overlap at curves.
7. Make a loop and pull the thread from the loop to end the stitch on the opposite side of the fabric

3 .EXPLAIN BUTTONHALL STITCH.

“This stitch is used to finish buttonholes; thus, the name ‘buttonholes stitch’”. This stitch is to create an outline, finish the edges or attach applique. It is also used for attaching mirrors in embroidery patterns these stitches are placed very close together to form a firm edge. At times, this stitch is used in the centre of a motif. The needle enters the same hole in the centre each time, making a hole in the centre while the wheel around it is filled completely. The buttonhole stitch is used for outlining and attaching mirrors in embroidery, for example, most of the mirror work in Gujarat and Rajasthan uses this stitch. It is use to make the corners of table covers, bed sheets, sofa covers, chair covers, saree borders, etc.

Follow the steps for making the buttonhole stitch:

1. Bring the needle out from below upwards, on the design line.
2. Base on the width of the stitch, insert the needle at one edge and take out from the other.
3. Before pulling the needle through the fabric, carry the thread under the needle point.
4. Embroider carefully to keep the width of the stitch even and work all the stitches very close together to keep the continuity.
5. In case of groups in the buttonhole stitch, even space should be maintained after each group.

6. Make a loop and pull the thread from the loop to end the stitch on the opposite side of the fabric.

4. WRITE A SHORT NOTE ABOUT FEATHER STITCH.

Feather stitch is used in double line and floral designs. In the double line designs, the stitches are taken with some gaps in between. In the floral designs, the stitches are taken close to each other as well as small in size. In this stitch, each loop is formed first to the right hand side and then on the left hand side of the embroiderer. All stitches should follow the same direction and should be equally spaced. This stitch is mostly use in women's wear like kurti, dresses and saree, etc.

Follow the steps for making a feather stitch:

1. Bring the needle from the backside to the front side on the line of the design.
2. Work stitches from the top to the bottom.
3. Every time the needle is pulled very gently, press the stitch under the thumb.
4. Because of the back-and-front movement of the needle, care should be taken to keep the stitches even on both sides of the central line.
6. Make a loop and pull the thread from the loop to end the stitch on the opposite side of the fabric.

MCQ ANSWER

- 1. Flat Stitches**
- 2. Chain Stitches**
- 3. Screw**
- 4. Back Side**
- 5. Loop Stitches**

UNIT: 4

PATCHWORK

4.0 OBJECTIVES**4.1 INTRODUCTION****4.2 TYPES OF PATCHWORK****4.3 TOOLS AND MATERIALS****4.4. CHECK YOUR PROGRESS I****4.5 METHOD****4.6 CHECK YOUR PROGRESS II****4.7 MULTIPLE CHOICE QUESTIONS****4.8 LET US SUM UP****4.9 KEYWORDS****4.10 SUGGESTED BOOKS****4.11 ANSWER**

4.0 OBJECTIVES

- To understand patchwork.
- To learn how to do patchwork on garments.
- To learn different techniques of patchwork.

4.1 INTRODUCTION

Patchwork is a creative art. Patchwork is the joining of pieces of fabric cuts and sew together to form a totally new surface. Patchwork is the use for make a surface decorative, creative and beautiful. It is mostly use in children wear and women's wear.

4.2 TYPES OF PATCH WORK

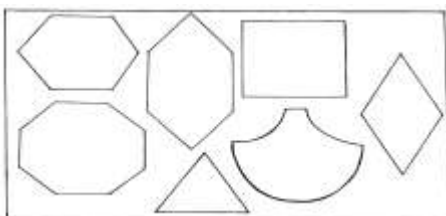
4.2.1 MOSAIC PATCHWORK

(fig.1. mosaic patchwork)

It is the easiest type of patchwork. In this patchwork pieces of fabrics are used in different shapes to form a geometric pattern and such patterns are set to one another to form a final pattern. Number of shapes in use are like squares, rectangles, triangles, diamonds, hexagons, pentagons, octagons, floral shapes, etc.

4.2.2. ONE SHAPE PATCHWORK



(fig.2. one shape patchwork)

In 'One Shape Patchwork' all pieces are the same shape and size. This patchwork can be made attractive by using different colour combinations and prints which are carefully arranged to produce an attractive overall design.

4.2.3 BLOCK- UNIT PATCHWORK:

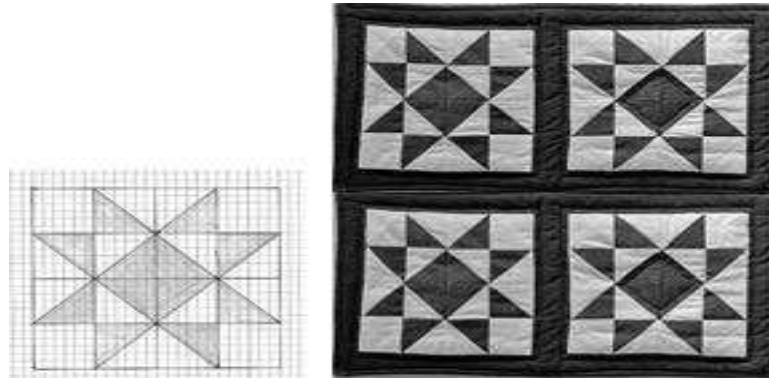

(fig.3.block-unit patchwork)

In 'Block Unit Patchwork' fabric pieces are joined first into a block, which becomes the basic shape. It is consist of precisely shaped pieces that forms a definite design within a square and when several such units are joined, a secondary overall design can be formed.

4.2.4 CRAZY PATCHWORK

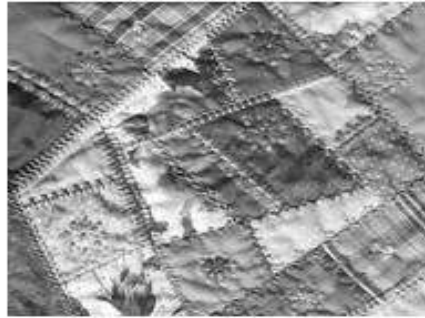
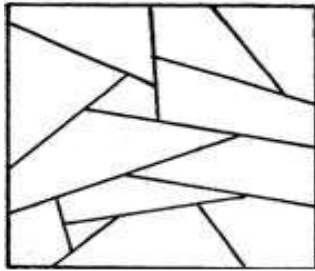

(fig.4. crazy patchwork)

Crazy Patchwork Design is unique piece block patchwork where in the pieces that form the design random sizes, shapes and colours. Originally, crazy patchwork work was one large block unit. An easier way of working is to sew the pieces to form small block units, and then sew them together.

4.2.5 DESIGNING PATCHWORK

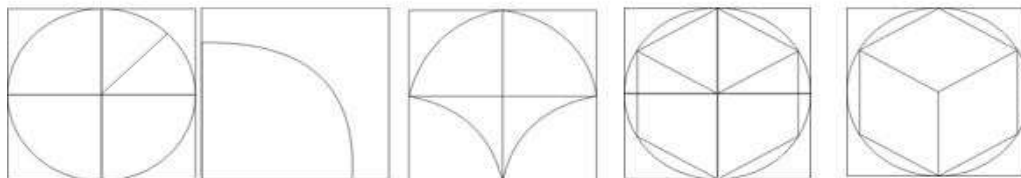
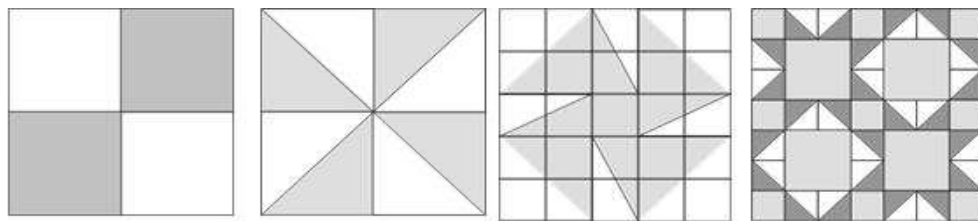

(fig.5. designing patchwork)

The simple and basic shape to use for patchwork designs is square. A square can be drawn accurately using the lines of graph paper as guides. During the designing of a pieced block, the square can be of any size, but before templates are made, it must be drawn to finished size. The more number of squares in a grid, the greater the number and the variety of potential

Shapes. Some pieced block designs are consist of just the grid squares and in some other designs, grid squares are grouped to form rectangles. Diagonal lines are also introduced to make intricate shapes. When a diagonal line is drawn through a square or rectangle, a triangle is formed. The triangle may be used alone or may be combined with other squares or rectangles to create shapes.

4.2.6 BORDERS AND DIVIDERS

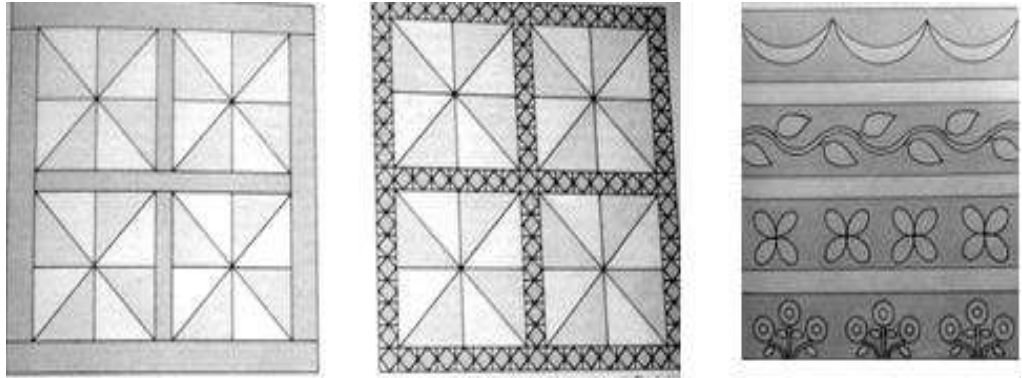

(fig.6. borders and dividers)

Two other elements of patchwork are Dividers and Borders which are used for providing to finishing the products. Dividers are sewed between the blocks and strips of blocks whereas borders are sewed to the outer edges of the joined patchwork units. Depending on the design, the strips can be made of continuous fabric lengths. They can be left plain or decorated with applique.

4.2.7. INFLUENCE OF COLOUR ON PATCHWORK DESIGN

Colour selection and placement are essential to the overall design impression of a patchwork. It is simple to choose and arrange single coloured fabrics for a single piece block, but for multi-block patchwork, the effect of different coloured fabrics on one another should be considered when the blocks are joined. Dominant colours are used to emphasize any area of the design. Both darker and lighter shades will create balance in the design if combined together. Emphasis should be given to the design that is to be clearly shown, either within the units or at their edges to create a secondary pattern. Placement of units also affects the design look. Prints with straight lines produce striping, where as small prints create an impression of dots. Colour fast patches produce durable patchwork.

4.3 TOOLS AND MATERIALS

- Some drawing tools like Ruler, pencil, graph paper, thin card board.etc
- Some sewing tools such as a Matching thread, hand needle, pins, scissors etc.
- Some suitable fabrics scrap saved from sewing and unworn parts of old garments can be used for patchwork.
- It is better to use non shrink fabric for patchwork

4.4. CHECK YOUR PROGRESS I

1. What is a patchwork?

2. How does colour influence the patchwork?

4.5 METHOD

METHOD OF WORKING PATCHWORK

4.5.1 Making templates

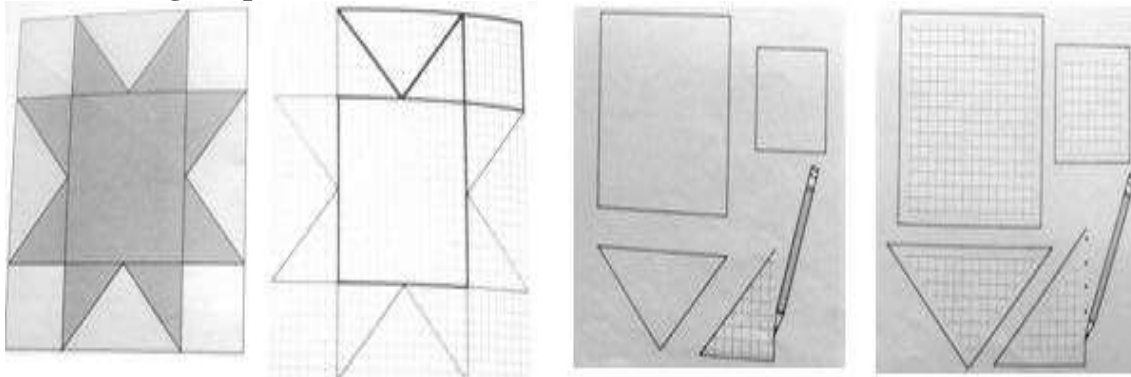

(fig.7. making templates)

The first step in the making of a patchwork is to make a cutting and marking template for different shapes in the design. To make templates of the correct size and shape, first draw the design of finished size required for templates on a graph paper. When units are drawn to finished size, check the combination of shapes that can be easily joined to form the units of the design. Carefully cut out each of the required shapes from the finished drawing. Place cut graph paper on a thick chart or cardboard and trace the shapes. Remove shapes and cut new pieces along the traced lines. These are called marking templates. Place graph paper shapes back on the heavy paper and mark $\frac{1}{4}$ th inch beyond each edge of the shape to make cutting templates. The $\frac{1}{4}$ th inch between the shape and edge of the template is the seam allowance needed to sew the pieces together. Patchwork pieces with curved edges may have notches that help to match seam lines. If a cardboard is used for templates and a shape is repeated, make several pieces of the same shape, as the templates can become worn and inaccurate.

4.5.2 Marking the fabric

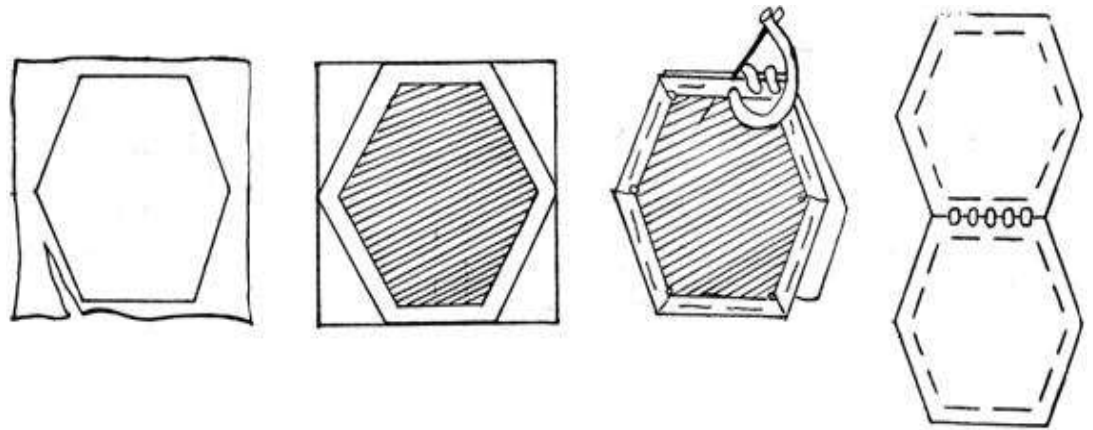

(fig.8. marking the fabric)

The cutting templates are used first to determine the amount of fabric needed for patchwork, then cut the pieces. Lay the fabric right side down on a flat hard surface and draw around the template with a sharp pencil. Repeat until all the pieces are drawn and make sure to draw correct shape on the correct colour of the fabrics. Cut the pieces along the marked lines and keep the different cut shapes separate. while marking triangles, mark them with the longest edge running along the grain line. Mark curve shapes with the curve on the bias, to allow them to be stretch and manipulate during sewing. To cut pairs of mirror image patches, if cutting from a single layer, cut a patch and then flip the template over to cut the second patch or if layer fabrics are used to cut alternately in a wrong and right way up. Marking templates are used in preparing cut fabric pieces for sewing. To mark seam lines, centre marking template on wrong side of the cut shape and using a pencil draw outline of the marking template onto the fabric. These are also used to make paper backing pieces for one shape patchwork.

4.5.3 Sewing patchwork

In hand technique, after cutting the patches using the templates, the seam allowances of the patches are turned to the wrong side and tacked. If lining or paper to each patch is required, the lining is placed on the wrong side in the centre before seam allowances are turned to the wrong side. To attach two patches together the patches are held right sides together, a row of fine closed overcast stitches are made. These stitches are seen as tiny close stitches on the

Right side.

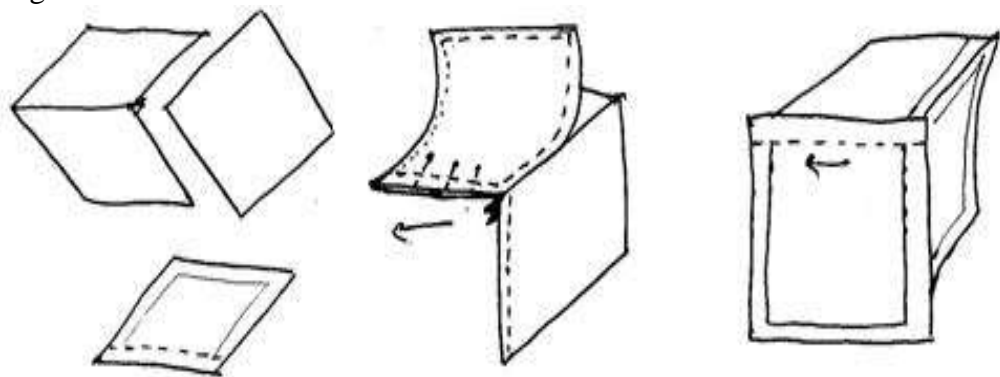

(fig.9. sewing patchwork)

4.5.4 Joining patches

For inset patches, first join the pieces that form the angle. Pin the piece to be inset along one side of the angle and starting at the inner corners of the seam, stitch from the inner angle to the outside edge. Next, pin the inset piece to the facing side of the angle and again stitch from the inner corner to the outside edge starting at the same point as the first stitching line. While joining rows and multiples of patches, pin carefully at each matching seam line, to ensure that the patches are correctly aligned. When pinning border strips ready for stitching, mark and pin the border strips at measured intervals corresponding to the patchwork pattern for an even fit.

4.5.5 Pressing

Press seams prior to sewing and always before the next stage in the piecing sequence. While joining rows and multiples of patches, pin carefully at each matching seam line, to ensure that the patches are correctly aligned. when pinning border strips ready for stitching, mark and pin the border strips at measured intervals corresponding to the patchwork pattern for an even fit.

4.6 CHECK YOUR PROGRESS II

3. Write any two types of patch work.

4. Write a short note on the method of patchwork.

4.7 MULTIPLE CHOICE QUESTIONS

1. _____ is the joining of pieces of fabric cut and sew together to form totally new surface.

- (A) Quilling
- (C) Patchwork

- (B) Applique
- (D) Batik work

2. In _____ patchwork all pieces are the same shapes and same sizes.
- (A) One shape patchwork (B) Mosaic patchwork
(C) Crazy patchwork (D) Designing patchwork
3. In which type of patchwork, pieces are joining first in to blocks?
- (A) Crazy patchwork (B) Block unit patchwork
(C) One shape patchwork (D) Border and divider
4. Which type of fabric is better for patchwork?
- (A) Shrieked (B) Non-shrieked
(C) Luster (D) Double layer
5. Correct method of patchwork is _____
- (A) Mark, sews, join, and press (B) Sew, mark, press, join
(C) Join, press, mark, sew (D) Join, press, sew, mark

4.8 LET US SUM UP

In this unit, we learnt on the fabric craft patchwork has been in use by using the fabric pieces or scraps which are worn out or any left out pieces without any advanced equipments. This is very simple to stitch and produce a variety of textile products. Patchwork is acquired by attaching the pieces of fabric cut in different shapes in the form of a design and it is mostly used in bed spreads, art quilt wall hangings, clothing, and a variety of textile products.

4.9 KEYWORDS

1. MOSAIC = a pattern product by arranging together small pieces.
2. CONSISTENT= method done in same way overtime.
3. PRECISELY= exactly, absolutely, right
4. ACCURATELY = correct, error-free, perfect, valid
5. POTENTIAL= possible, likely, probable
6. INTRICATE = complex, complicated, tangled, twisted
7. ELEMENTS = part, section, portion
8. ESSENTIAL= crucial, key, important, necessary
9. DOMINANT= superior, commanding
10. INACCURATE= incorrect, wrong, faults
11. DETERMINE= control, decide, regulate
12. MANIPULATE= operate, handle, control
13. FLIP= overturn, upturn, turnover
14. ALIGNED= line up, range, arrange in line
15. INTERVALS= meanwhile, meantime
16. CORRESPONDING= have a close similarity, match almost everything

4.10 SUGGESTED BOOKS

1. Complete Guide Of Needlework
2. Turnabout Patchwork: Simple Quilt With Twist
3. Morden Patchwork By Elizabeth Hartman

4. The practical Guide To Patchwork By Elizabeth Hartman
{ Note: Figures Are Adapted From Suggested Book List And Source Of
Non-Copyrighted Materials }

4.11 ANSWER

1. What is a patchwork?

patchwork is a creative art. Patchwork is the joining of pieces of fabric cut and sew together to form a totally new surface. Patchwork is use for make a surface decorative, creative and beautiful. It is mostly use in children wear and women's wear

2. How does colour influence the patchwork?

colour selection and placement are essential to the overall design impression of a patchwork. It is simple to choose and arrange single coloured fabrics for a single pieced block but for multi-block patchwork the effect of different coloured fabrics on one another should be considered when the blocks are joined. Dominant colours are use to emphasize any area of the design. By combining both darker and lighter shades will create balance in the design. Emphasis should be given to the design that is to be clearly shown either within the units or at their edges to create a secondary pattern. Placement of units also affects the design look.

3. Write any 2 types of patch work.

1. block- unit patchwork:

In block unit patchwork fabric pieces are joined first into a block, which becomes the basic shape. It consists of precisely shaped pieces that form a definite design within a square and when several such units are joined a secondary overall design can be formed.

2. Crazy patchwork:

Crazy patchwork design is unique piece block patchwork in that pieces that from the design is random sizes, shapes and colours. Originally, crazy patchwork work as one large block unit. An easier way of working is to sew the pieces to from small block units, and then sew this block together.

4. Write a short note about method of patchwork.

1. Making templates

The first step in the making of a patchwork is to make a cutting and marking template for different shapes in the design. To make templates of the correct size and shape, first draw the design on a graph paper to finished size that require templates. When units are draw to finish size, check the combination of shapes that can be easily joined to form the units of the design. Carefully cut out each of the required shapes from the finished drawing. Place cut graph paper on a thick chart or cardboard and trace the shapes. Remove shapes and cut out new pieces along the traced lines. These are called marking templates. Place graph paper shapes back on the heavy paper and mark $\frac{1}{4}$ th inch beyond each edge of the shape to make cutting templates. The $\frac{1}{4}$ th inch between the shape and edge of the template is the seam allowance needed to sew the pieces together. Patch work pieces with curved edges may have notches that help to match seam

lines. If a cardboard is used for templates and a shape is repeated, make several pieces of the same shape as the templates can become worn and inaccurate.

2. Marking the fabric

The cutting templates are used first to determine the amount of fabric needed for patchwork, then cut out the pieces. Lay the fabric right side down on a flat hard surface and draw around the template with a sharp pencil. Repeat until all the pieces are drawn and make sure to draw correct shape on the correct colour of the fabrics. Cut the pieces along the marked lines and keep the different cut shapes separate. While marking triangles, mark them with the longest edge running along the grain line. Mark curve shapes with the curve on the bias, to allow them to be stretched and manipulated during sewing. To cut pairs of mirror image patches, if cutting from a single layer, cut a patch and then flip the template over to cut the second patch or if layer fabrics are used, cut alternately in a wrong and right way up. Marking templates are used in preparing cut fabric pieces for sewing. To mark seam lines, centre marking template on wrong side of the cut shape and using a pencil draw outline of the marking template onto the fabric. These are also used to make paper backing pieces for one shape patchwork.

3. Sewing patchwork

In hand technique, after cutting the patches using the templates, the seam allowances of the patches are turned to the wrong side and tacked. If lining or paper to each patch is required, the lining is placed on the wrong side in the centre before seam allowances are turned to the wrong side. To attach two patches together the patches are held right sides together, a row of fine closed overcast stitches are made. These stitches are seen as tiny, close stitches on the Right side.

4. Joining patches

For inset patches, first join the pieces that form the angle. Pin the piece to be inset along one side of the angle and starting at the inner corners of the seam, stitch from the inner angle to the outside edge. Next, pin the inset piece to the facing side of the angle and again stitch from the inner corner to the outside edge starting at the same point as the first stitching line. While joining rows and multiples of patches, pin carefully at each matching seam line, to ensure that the patches are correctly aligned. When pinning border strips ready for stitching, mark and pin the border strips at measured intervals corresponding to the patchwork pattern for an even fit.

5. Pressing

Press seams prior to sewing and always before the next stage in the piecing sequence. While joining rows and multiples of patches, pin carefully at each matching seam line, to ensure that the patches are correctly aligned. When pinning border strips ready for stitching, mark and pin the border strips at measured intervals corresponding to the patchwork pattern for an even fit.

- 1. Patchwork**
- 2. One Shape Patchwork**
- 3. Block Unit Patchwork**
- 4. Non-Shrunked**
- 5. Mark, Sew, Join, Press**

UNIT: 5

APPLIQUE WORK

5.0 OBJECTIVES**5.1 INTRODUCTION****5.2 TYPES OF APPLIQUE****5.3 TOOLS AND MATERIALS****5.4. CHECK YOUR PROGRESS I****5.5 METHOD****5.6 CHECK YOUR PROGRESS II****5.7 MULTIPLE CHOICE QUESTIONS****5.8 LET US SUM UP****5.9 KEYWORDS****5.10 SUGGESTED BOOKS****5.11 ANSWER**

5.0 OBJECTIVES

- To gain knowledge of applique work.
- To learn different method of doing applique work.
- To understand the difference between applique and reverse applique work.

5.1 INTRODUCTION

Applique is a fabric cut out attached on the surface of a larger piece of fabric. Applique work is basically a sewing craft. There are many ways to do applique work. Buttonhole stitch, satin stitch, are used to attach applique. Applique can be made almost on all fabrics. It signifies that at least one different piece of fabric has been placed over or under another and is held with embroidery stitches.

5.2 TYPES OF APPLIQUE

5.2.1. Raw edge applique:

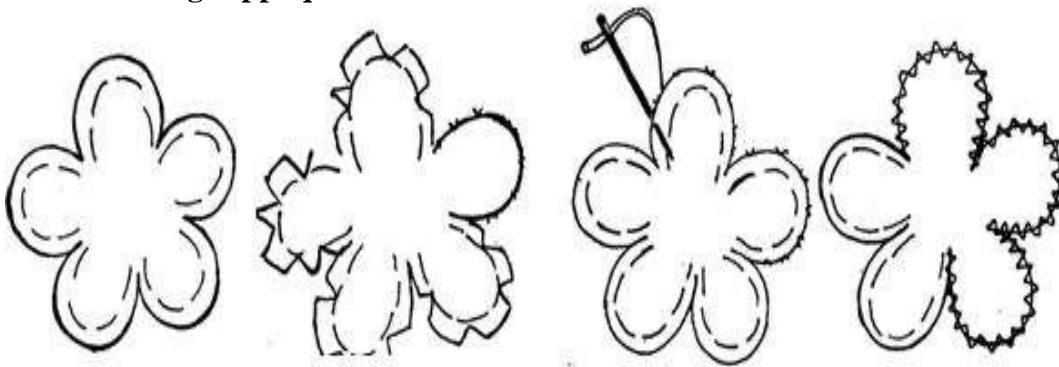

(fig.1. raw edge applique)

In this applique edges of the cut-outs are not finished, cut out are sewed with embroidered stiches like straight stiches or multi stiches. Because the edges are not significance the cut out seams to merge with the background fabric.

5.2.2. Satin -stitched applique:

Tightly spaced zigzag stiches from a small ridge around the cut out accents the edges and gives the applique significance.

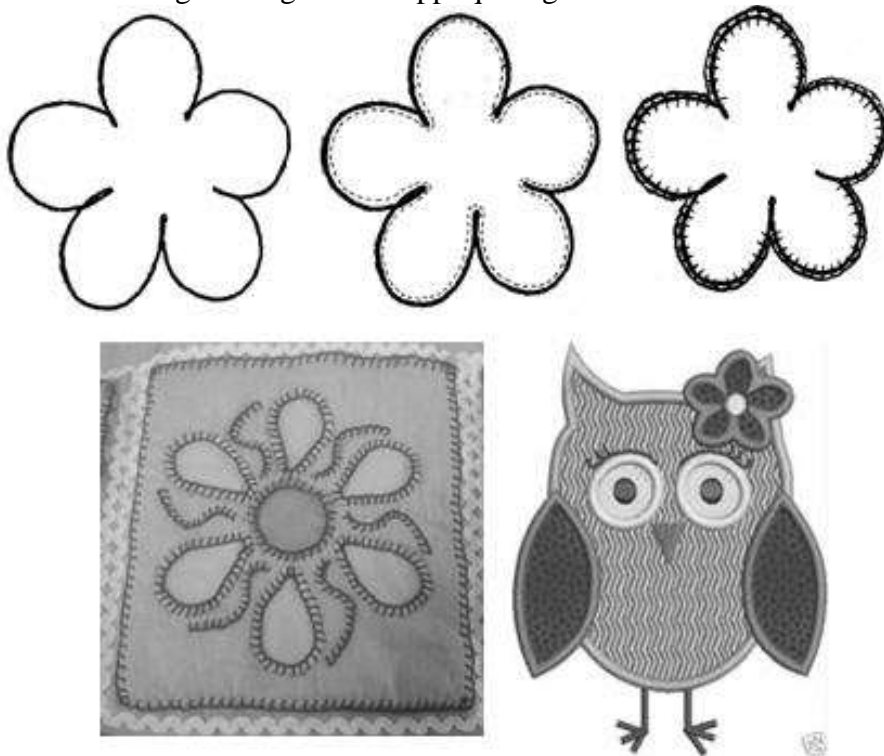

(fig.2. satin stitched applique)

5.2.3. Couched applique:

Cut-outs are secured by couching a decorative cord around the outer edge, creating a ridge and finishing the cut edges.

5.2.4. Buttonhole applique:

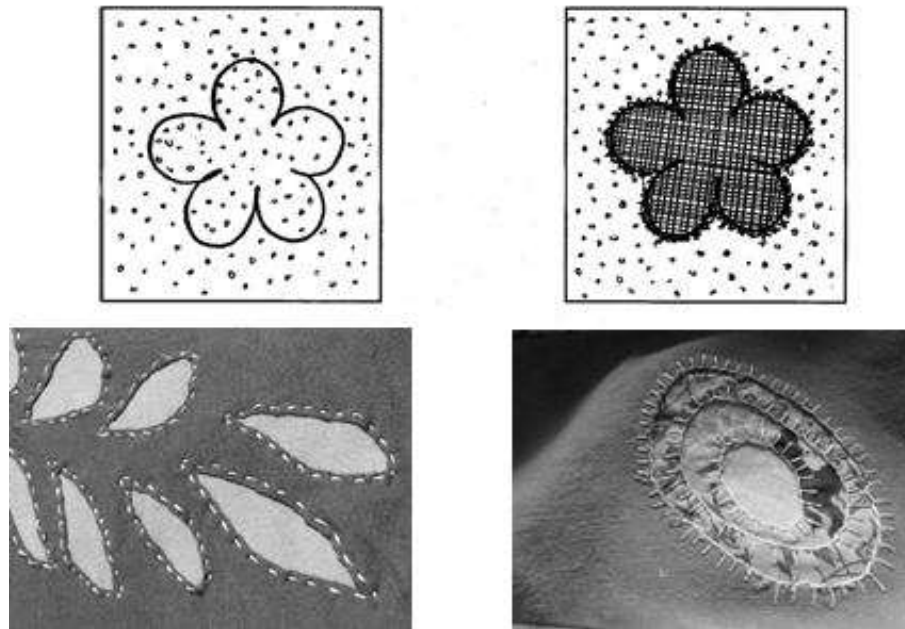

(fig. 3 buttonhole stitch)

in this applique, the raw edges are finished using button hole stitch.

5.2.5. Chain stitched applique:

in this applique the raw edges are finished with chain stitch.

5.2.6 Reverse Applique:

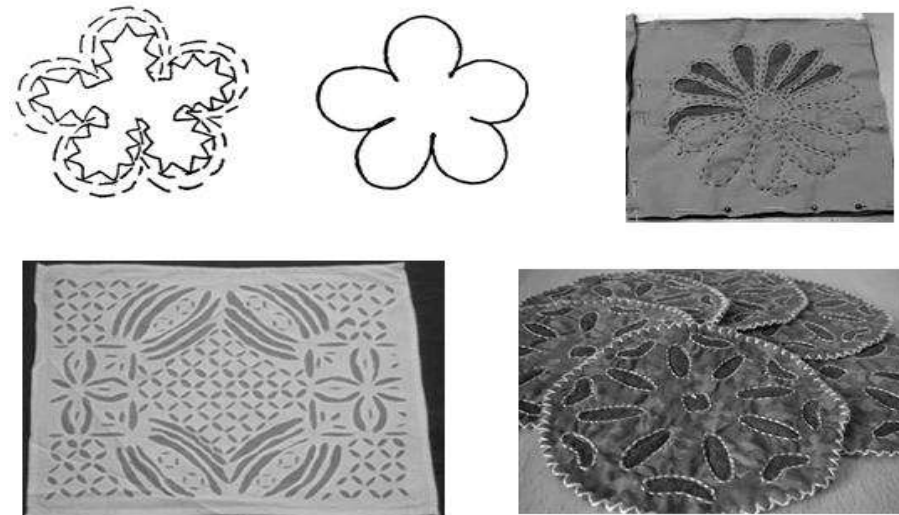

(fig.4. reverse applique)

in this applique a motif cut-out from the main ground to reveal another fabric, Two layers of fabric are taken and the edges of the top fabric are cut in a particular design and turned under to reveal the underlying fabric. The two layers of fabric are held in place by tacking outside the design. The top layer of fabric is then carefully cut about 8 mm inside the Mark outline. The excess is turned under by making small cuts for accommodating the curves and hemmed.

5.3 TOOLS AND MATERIALS

- Simple tools such as scissors, pins, needle, thread, frame, thimble etc.
- Drawing materials like tracing paper, pencil, tailors chalk or carbon paper, thick paper for templates etc.
- Fabric pieces or scraps of different types.
- Fabrics of all types can be utilized for making applique. To make sewing easy, it is better to avoid stretchable, loosely woven or bulky fabrics. Firm, closely woven and colour fast fabrics increase the durability of the Applique work.
- Poplin material is used for most of the applique and in all cases the fabric is pre-shrunk.
- Cotton fabrics with prints or solids are chosen that will hold necessary crease as the motifs are applique onto the ground fabric.
- The selected fabric could be the same fabric as the backing or one of the applique motifs or in a complementary colour or pattern.
- Printed or solid colour cotton fabrics that combine well in colour and design. The lengthwise grain line of the backing fabric should run the length of the applique work to keep it straight through many types of washing.

5.4. CHECK YOUR PROGRESS I

1. What is an applique?

2. Write any five types of applique technique.

5.5 METHOD

5.5.1. Designing an applique

Inspiration for applique designs can be found in many sources like nature, Man-made and everyday objects. A simple design can consist of a central Motif cut from a single piece or more than two pieces. It consists of different types of Motifs and fabric types together that form a complete

picture. The motifs can be drawn or traced and cut to form templates. To make template cut along the drawn outline of the applique piece. If the design consists of two or more pieces retrace each piece separately. Straighten out the edges that is covered by another piece instead of cutting the exact shape.

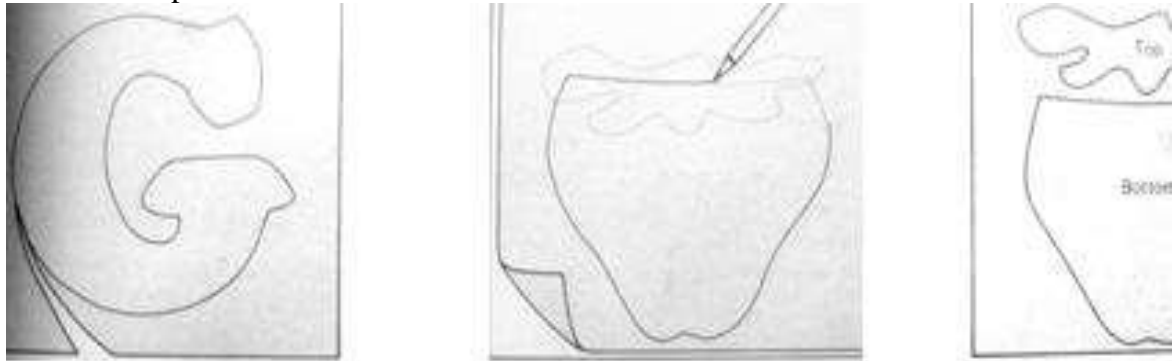

(fig. 5 designing an applique)

5.5.2. Transferring designs

Before transferring a design, cut background fabric of the desired size. Mark the centre lines by folding and creasing the background fabric on the folds. To transfer the design, position the template right side up on background fabric and pin it in place. Trace around the template using either a sharp pencil or pen. if the design has two or more pieces, assemble all the pieces into their correct positions and pin them to the background fabric. Trace around the design formed by the template.

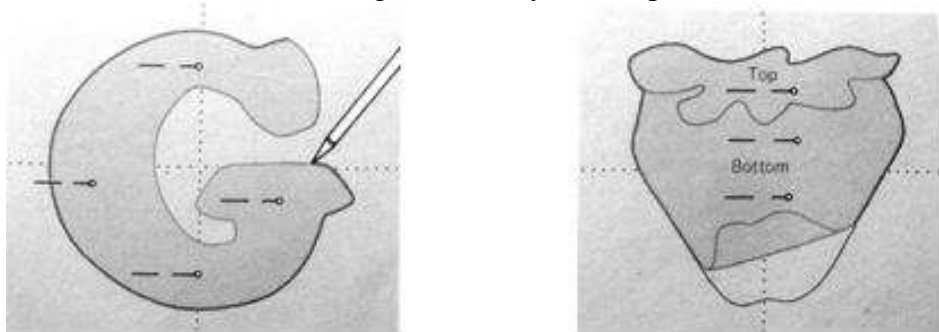

(fig 6. transferring designs)

5.5.3. Cutting applique

The first step is to decide the kind of fabric pieces or scraps used to make the design. An interesting overall design can be achieved by balancing the colours, prints, solids and textures. Another consideration is the compatibility of the applique fabric and the background fabric in terms of care. If the applique has to be laundered, the compatibility of the fabrics used should be checked in order to prevent shrinkage while washing or bleeding of colour from one fabric to another.

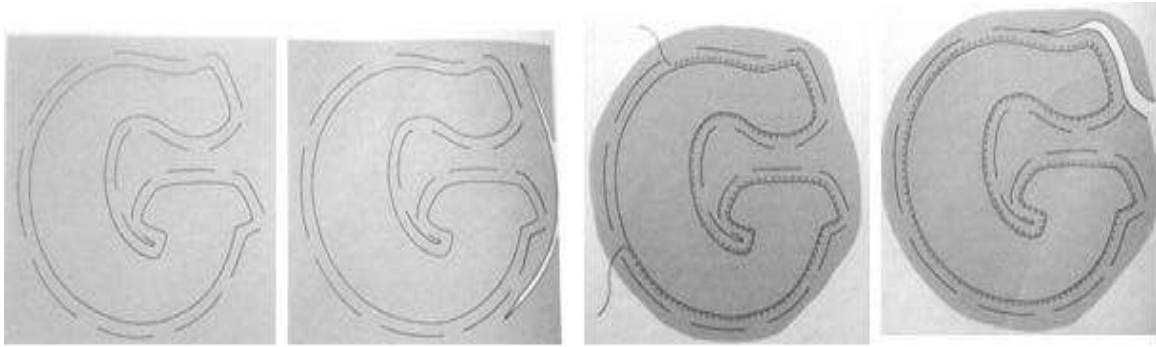

(fig.7. cutting applique)

To cut the applique, pin the template on the right side of the fabric and trace the outline of the template, and mark required seam allowance outside the seam line. Wide seam allowances are given to the loosely woven fabric. Cut margins of the fabric so that enough fabric is left to facilitate for stay stitching. After cutting the outer margin line, stitch outside the inner marked seam line to facilitate easy turning. It can be done on the sewing machine by setting the stitch length to 12-15 stitches per inch. Stay stitching is recommended to make easier to turn the edges. Now trim the margin by cutting the applique on outer marked line. Clip seam allowances around curves and corners so that the edges can be properly turned.

5.5.4. Cutting curves and corners and sews

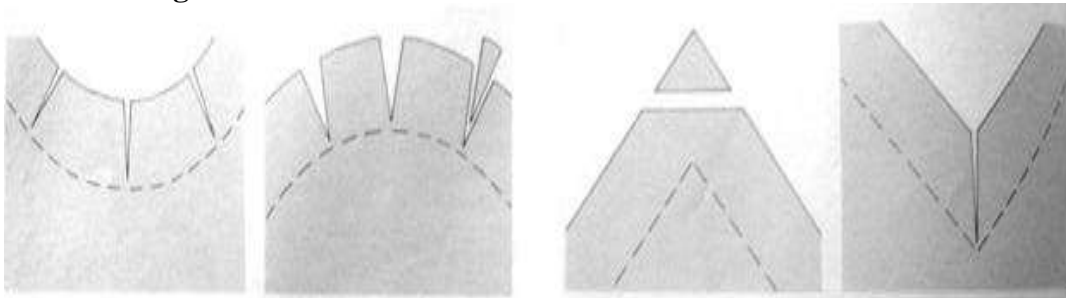

(fig. 8. cutting curves and corners and sews)

In order to make the applique turn easily while stay stitching the curves and corners, the seam allowances should be slightly trimmed accordingly. For inner curves clip seam allowances on the inner side of the curve. Keep the space between the clips closer together along the deeper curves. For outer corners notch out pieces along seam allowances, to avoid forming of bulky pleats when the edges are turned on. At outside corners, blunt the seam allowances to help reduce the formation of bulky pleat while stay stitching, whereas for inside corners slightly clip into the point of the corner to allow ease for stay stitching.

5.6 CHECK YOUR PROGRESS II

3. Write a list of tools and material used for applique.

4. Explain method of applique.

5.7 MULTIPLE CHOICE QUESTIONS

1. Applique is _____ technique.
(A) a Paint (B) Draw a design
(C) a Cut out and attached (D) a Sewing
2. Button hole applique are finished by using _____ stitch.
(A) Satin stitch (B) Back stitch
(C) Button hole stitch (D) Feather stitch
3. In which applique motif cut-out from the main ground to reveal another fabric?
(A) Button hole (B) Couched applique
(C) Hand applique (D) Reverse applique
4. _____ material is use for most to the applique s and all eases the fabric is pre-shrunk.
(A) Silk (B) Poplin
(C) Georgette (D) Velvet
5. A piece of cut out and attach it on fabric is _____ method.
(A) n applique (B) a patch
(C) a quilting (D) a block print

5.8 LET US SUM UP

In this unit, we learnt that the fabric craft applique has been in use by using the fabric pieces or scraps which are worn out or any left out pieces without any advanced equipment. This is very simple to stitch a variety of textile products applique work is attained by sewing pieces of fabrics onto a ground fabric according to the design. It is mostly used in bed spreads, art wall hangings, clothing, and a variety of textile products. Basic stitches like running stitch, back stitch, slip stitch, buttonhole, zig zag etc. are used for finishing. It depends on the design and interest of the designer.

5.9 KEYWORDS

1. APPLIQUE= decorate garment with pieces of fabric .
2. SURFACE=the outside part or layer of fabric.
3. VARIOUS=varied, different from one another.
4. SIGNIFICANCE=the quality of being worthy of importance.
5. RAW EDGE= an unfinished, rough piece
6. SEAM =a line where two pieces of fabric are sewn together.
7. MERGE= combine, unite
8. RIDGE= a long, narrow hilltop.
9. ACCENTING= one associated with a particular area or place.
10. REVEAL= release, disclose.
11. UNDERLYING= lying beneath or below
12. ACCOMMODATING= provide lodging or sufficient space for.
13. FABRIC SCRAP= too small, too little part of fabric.
14. COMPLEMENTARY=supportive, matching, corresponding
15. PREVENT=to keep, put a stop to, turn aside.
16. SHRINKAGE=to process, or amount of shrinking.
17. MARGIN= border, age, side, boundary
18. RECOMMENDED= put forward, nominate, put up, approve

5.10 SUGGESTED BOOKS

1. The Big Book Of Pretty And Play full applique- Carol Armstrong
 2. Kim Diehl- Simple Applique
 3. Complete Guide Of Needlework
- { Note: Figures Are Adapted From Suggested Book List And Source Of Non-Copyrighted Materials }

5.11 ANSWER

1. What is an applique?

Applique is a fabric cut out attached on the surface of larger piece of fabric. Applique work is basically a sewing craft. There are many ways to do applique work. Buttonhole stitch, satin stitch, is used to attach applique. Applique can be made almost on all fabrics. It signifies that at least one different piece of fabric has been placed over or under another and is held in place with embroidery stitches

2. Write any five types of applique technique.

1. Raw edge applique: In this applique edges of the cut out are not finished, cut out sew with embroidered stitches like straight stitches or multi stitches. Because the edge are not significance the cut out seams to merge with background fabric.
2. Satin – stitched applique: Tightly spaced zigzag stitches form a small ridge around the cut out accenting the edges and giving the applique significance.
3. Couched applique: Cut-outs are secured by couching a decorative cord around the outer edge, creating a ridge and finishing the cut edges.
4. Button hole applique: In this applique raw edges are finished using button hole stitch.
5. Chain stitched applique: in this applique the raw edges are finished with chain stitch.

3. Write a list tools and material uses for applique.

- Simple tools such as scissors, pins, needle, thread, frame, thimble etc.
- Drawing materials like tracing paper, pencil, tailors chalk or carbon paper, thick paper for templates etc.
- Fabric pieces or scraps of different types
- Fabrics of all types can be utilized for making applique. To make sewing easy, it is better to avoid stretchable, loosely woven or bulky fabrics. Firm, closely woven and colour fast fabrics increase the durability of the Applique work.
- Poplin material is use for most of the applique and in all cases the fabric is pre-shrunk.
- Cotton fabrics with prints or solids are chosen that will hold necessary crease as the motifs are applique onto the ground fabric.
- The selected fabric could be the same fabric as the backing or one of the applique motifs or in a complementary colour or pattern.
- Printed or solid colour cotton fabrics that combine well in colour and design. The lengthwise grain line of the backing fabric should run the length of the applique work to keep it straight through many types of washing.

4. Write method of applique

1. Designing an applique:

Inspiration for applique designs can be found in many sources like nature, Man-made and everyday objects. A simple design can consist of a central Motif cut from a single piece or more than two pieces. It consists of different Motifs and fabric types together that form a complete picture. The motifs can be drawn or traced and cut to form templates. To make template cut along the drawn outline of the applique piece. If the design consists of two or more pieces retrace each piece separately. Straighten out the edges That is covered by another piece instead of cutting the exact shape.

2. Transferring designs:

Before transferring a design, cut background fabric of the desired size. Mark the centre lines by folding and creasing the background fabric on the folds. To transfer the design, position template right side up on background fabric and pin in place. Trace around the template using either a sharp pencil or pen. If the design has two or more pieces, assemble all pieces into their correct positions and pin them to the background fabric. Trace around the design formed by the template.

3. Cutting applique:

The first step is to decide the kind of fabric pieces or scraps used to make the design. An interesting overall design can be achieved by balancing the colours, prints, solids and textures. Another consideration is the compatibility of the applique fabric and the background fabric in terms of care. If the applique has to be laundered, the compatibility of the fabrics used should be checked in order to prevent shrinkage while washing or bleeding of colour from one fabric to another. To cut the applique, pin the template on the right side of the fabric and trace the outline of the template,

and mark required seam allowance outside the seam line. Wide seam allowances are given to the loosely woven fabric. Cut margins of the fabric so that enough fabric is left to facilitate for stay stitching. After cutting the outer margin line, stitch outside the inner marked seam line to facilitate easy turning. It can be done on the sewing machine by setting the stitch length to 12-15 stitches per inch. Stay stitching is recommended to make easier to turn the edges. Now trim the margin by cutting the applique on outer marked line. Clip seam allowances around curves and corners so that the edges can be properly turned.

4. Cutting curves and corners and sews:

In order to make the applique turn easily while stay stitching the curves and corners, the seam allowances should be slightly trimmed accordingly. For inner curves clip seam allowances on the inner side of the curve. Keep the space between the clips closer together along the deeper curves. For outer corners notch out pieces along seam allowances, to avoid forming of bulky pleats when the edges are turned on. At outside corners, blunt the seam allowances to help

MCQ ANSWER

- 1. Cut Out And Attached**
- 2. Buttonhole Stitch**
- 3. Reverse Applique**
- 4. Poplin**
- 5. Applique**

UNIT: 6

CROCHET

6.0 OBJECTIVES**6.1 INTRODUCTION****6.2 CROCHET ABBREVIATIONS****6.3 TOOLS AND MATERIALS****6.4. CHECK YOUR PROGRESS I****6.5 METHOD****6.6 CHECK YOUR PROGRESS II****6.7 MULTIPLE CHOICE QUESTIONS****6.8 LET US SUM UP****6.9 KEYWORDS****6.10 SUGGESTED BOOKS****6.11 ANSWER**

6.0 OBJECTIVES

- To gain knowledge about crocheting
- To learn basic patterns of crochet
- To learn to make designs by crocheting

6.1 INTRODUCTION

Crochet is a method of creating fabric from yarn or thread, by using a hook and a ball of yarn. The word crochet comes from the old French word “crouches” or “croc” meaning hook. Originated in France during the 16th century, crochet was used as a simple method of making lace. It was especially popular during the early part of the 20th century as edgings for linen tablecloths and petticoats. Today crochet remains an important needle art as it swings in and out of fashion prominence. One of the reasons it continues to be popular is, it requires very few equipment and little time. With different kinds and textures of yarn available it is easy to create many beautiful and useful crocheted items.

6.2 CROCHET ABBREVIATIONS

1. beg - begin(ning)

2. ch - chain
3. sc - single crochet
4. dc - double crochet
5. hdc - half double crochet
6. tr - treble crochet
7. st - stitch(es)
8. sl - slip
9. sk - skip
10. yo - yarn over
11. in - increase
12. rep - repeat
13. rnd(s) - round(s)
14. lp - loop
15. RS - right side
16. WS - wrong side
17. tog - together
18. *, **, + or ++ - repeat whatever follows
19. the *, **, + or ++ as indicated
20. [] - work instructions in brackets
21. The number of times indicated.

6.3 TOOLS AND MATERIALS

Equipment and materials for crochet are very few and simple to use. along with a hook, yarn, and scissors, other optional items will come in handy.

Hooks: Commonly made from plastic, aluminium, steel, or wood are available in many sizes. Some are as fine as a pin head. Others are as fat as



a broomstick.

(fig.1. hook or crochet needle)

Scissors: A small pair of blunt-end scissors in good condition is preferred

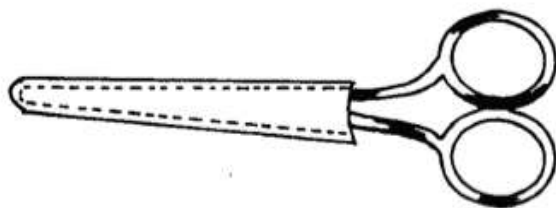

(fig.2. scissor)

T pins: Use for blocking and securing pieces of project together when joining or measuring.

Yarn needle:



(fig.3. yarn needle)

Made of plastic or metal with a blunt point and large eye. It is used to hide loose ends when joining yarn or when project is finished.

Tape measure: Generally used to measure "you" and/or length and width of project as you establish the gauge needed by the pattern.

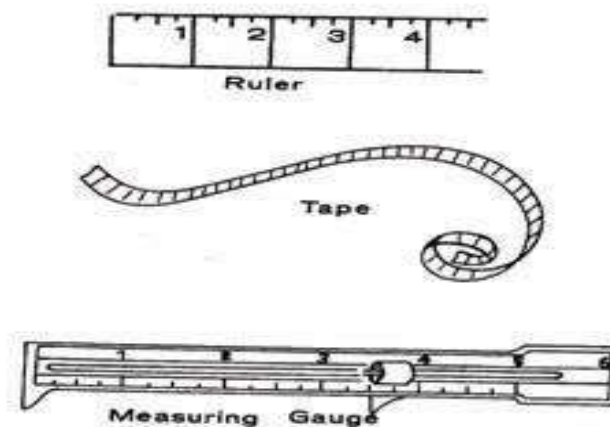

(fig.4. tape measure)

Gauge ruler: A 2-inch L shaped window item that allows you to measure the number of stitches and rows in an inch.

Split markers: Round plastic spiral markers that slip into crochet work. They are used to indicate a certain point in crocheting such as joining continuous rounds, increase points or decrease points.

Small note pad and pencil: Useful to help you keep track of what row or round you are crocheting and the number of times you have repeated stitches when part of the instructions in a row are to be repeated.

YARN

Yarns are available in a variety of weights (thickness of the strands) and fiber contents.

for best results, use the yarn specified in the instructions. Be sure to purchase all the yarn you need for a project at the same time because dye lots may vary a little in shading

and this will show on the finished project. if you are combining different types of yarn in the same project, make sure they have similar washing instructions. Care instructions are found on the product label—follow them carefully. always make sure to make a swatch.

GAUGE

Gauge is the number of stitches (and spaces) per inch and the number of rows (or rounds) per inch. In many patterns, gauge is specified over 4 inches. Your gauge and the gauge specified in the pattern must be the same so that your project will be the correct size. This is especially crucial for projects that must fit. Before starting your project, take the time to make a gauge swatch. To check gauge, use the same yarn, hook and pattern stitch specified in the instructions. Make a swatch that is approximately 6 inches square. Work in pattern for about 6 inches, and then bind off. Let the swatch relax for a bit, and then flatten it without stretching to measure. Using pins mark off a section of stitches in the centre of the swatch that measures 4 inches square. Count the number of stitches and rows in this 4 inch section. If they match the gauge, you can start right in on your pattern.

6.4. CHECK YOUR PROGRESS I

1. What is a crochet work?

2. Write any three tools for crochet.

6.5 METHOD

Slip Knot and Chain Stitch:

All crochets begin with a slip knot and then on to make a chain stitch. The knot

and stitch is used as a foundation or base for other stitches, to start a new row or to form pattern stitches.

To make a slip knot:

1. Form a loop about 6 inches from the end of the yarn.
2. Pick up hook and hold it as you would a pencil or hold the hook in a manner that is comfortable.



(fig.5. hold a needle)

3. Hook another loop through the loop you have already formed

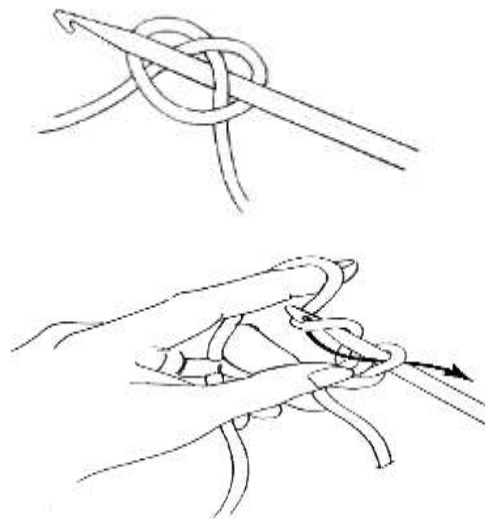

4. Pull the knot close to the hook, but not so tight or else it will not slide on the hook.

To make a chain stitch:

Abbreviations:

ch.....chain

st.....stitch

yo.....yarn over

1. Holding the hook with the slipknot in the right hand, thread yarn around the fingers of you left hand.

2. Yarn over (yo) and draw yarn through the loop on the hook. This makes



one chain.

3. Repeat Step 2 until you have the number of stitches needed. Practice until your chain stitches are about the same size and not tight.

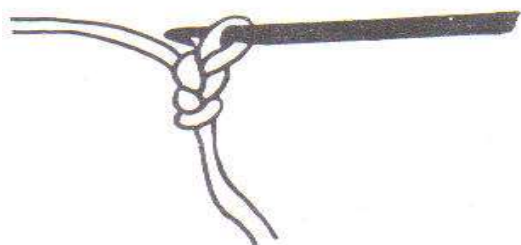

4. After making several chain stitches, look at your chain. The front of the chain has a series of V's coming out of each other. The back has raised loops in the center. Unless the pattern gives other instructions, always crochet in the front of the chain.

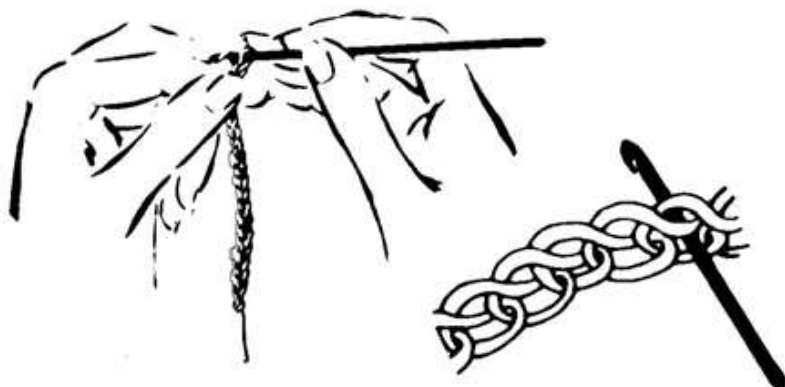

Basic Crochet Stitches

There are several basic stitches.

Single Crochet (sc):

The single crochet stitch is the shortest and most compact of the basic stitches.

1. Chain 11 (ch 11).

2. Insert the hook in the second ch from hook, under the top two threads as shown.



3. Wrap the yarn over (yo) hook. 4. Draw through stitch. There are now two loops on hook.



5. Yo and draw yarn through two loops on hook. One loop remains. You have completed one single crochet (sc) stitch (st). Repeat Steps 2 through 5 in each chain stitch. You will have 10 sc stitches.



To crochet another row, ch 1 and turn the work around so the reverse side faces you. The chain at the end of the row is called the turning chain. You always make a turning chain at the end of a row unless directions instruct otherwise. To crochet another row, insert the hook in the first st, under the top two yarns and continue following Steps 2 through 4. Count your stitches. You should have 10 sc stitches.

Slip Stitch (sl st):

The slip stitch has many uses. It can be used to make a thicker chain or edging, To join rounds, to move one or more stitches over in your work, and to end your work smoothly.

1. Insert hook through 2 loops of the chain stitch or the row you are working on.

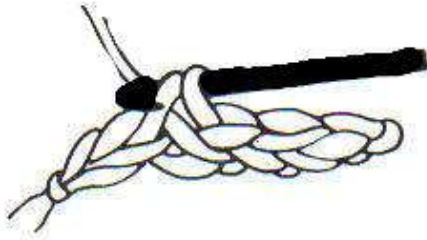

2. Pull yo through all loops on the hook.

Double Crochet (dc):

The double crochet stitch is taller and creates work that is more open and lacy like than a sc stitch.

1. Chain 12 (ch 12).
2. Yo and insert the hook under 2 loops in the fourth chain from the hook.



3. Yo over and pull through. You have 3 loops on hook.



4. Yo and pull through 2 loops



5. Yo and draw through the remaining 2 loops. One loop remains on hook. 1 dc stitch completed



6. Repeat Steps 3 through 5 to the end of the row, ch 3, and turn. The turning chain counts as a dc stitch. Insert hook in the next stitch (under the top two loops) to make the next dc.



Half Double Crochet (hdc):

The half double crochet stitch is taller than a single crochet stitch but not as tall as a double. It makes a firm textured fabric.

1. Chain 12 (ch 12).
2. Yo and insert the hook in the third ch from hook

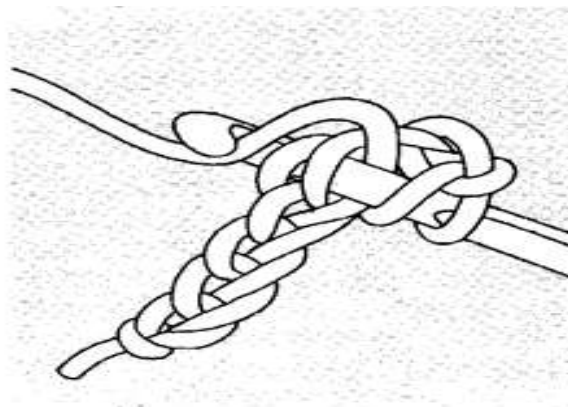

3. Yo and pull through. There are 3 loops on the hook.

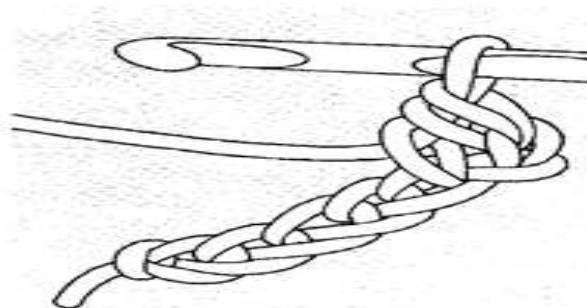

4. Yo and pull through all 3 loops. Half double crochet stitch is completed. Repeat Steps through 4 across chain to the end. There are 10 hdc sts.

5. Ch 2 turn, yo and insert hook in the second stitch under the top two Loops, yo, draw through all three loops. Repeat across row to end.

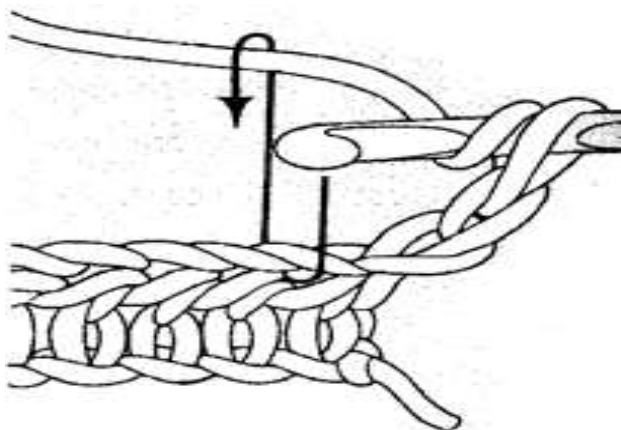

There are 10 hdc Sts. (ch 2 counts as a hdc)

Treble Crochet (tr):

Sometimes called triple stitch, the treble stitch is taller and more open than a

Double stitch. It is a continuation of the double crochet stitch.

1. Ch 14.

2. Yo hook twice; insert hook under two loops of the fifth chain from hook.



2. Yo hook and draw up a loop. There are four loops on the hook.



3. Yo hook and pull through two loops. Yo hook again and pull through two loops.



4.



5. Yo hook and pull through remaining two loops.

6. There should be only one loop on the hook. Your treble stitch is complete.



Repeat Steps 2 through 6 until row is complete. When turning for the next row, chain four, yo 2 times and insert hook in 2nd st, complete as before to finish treble stitch. Turning chain counts as a tr stitch. usually. This can be worked as a treble stitch, also.

Fastening and Hiding Yarn Ends

After the last stitch, it is very important to fasten the yarn ends and hide them. Fastening off will keep your work from raveling out. Hiding the ends will give it a neat and complete appearance.

1. After the last stitch, cut the yarn 6 to 8 inches long from the finished Work, or as specified by the pattern directions.



2. Next pull the end of the yarn through the loop, pulling snugly but Not too tightly. This will knot the yarn securely.

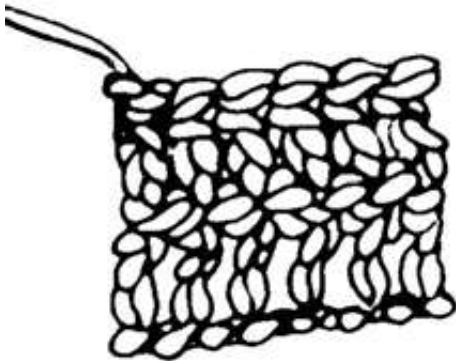

5. Bring all loose yarn ends to the wrong side. Using the yarn needle, thread it with the yarn end and weave the yarn in the top of the row for about 2 inches. Turn back and weave over the same area for about 1 inch. Cut the end close to the work, but be careful not to cut the project. Never cut the yarn off close to the end right after the last stitch. The yarn will come untwisted and look fuzzy.

Attaching a New Yarn

Sometimes yarn will have knots, colour imperfections, or an extra thick blob of Threads in one spot. Maybe the project calls for more than one skein of yarn. Join yarn in the middle of the work or at the end of a row.

To join new yarn – at the end of a row:



1. Crochet up to the last stitch. Work last stitch until two loops remain on hook.

Loop new yarn to be attached around hook, leaving a 6-inch tail beyond the hook.



2. Draw a loop of the new yarn through the 2 loops on the hook.
3. Continue crocheting with new yarn. If possible, keep both short ends of yarn on the wrong side of the work (if that is not possible, you can pull them through to the wrong side later). After crocheting 6 or 7 stitches, check the tension where the yarn was joined.

Working in Rounds

A round is the name given to crochet that is worked in a continuous circle not Turned from front to back as in rows. All motifs start as rounds or circles but may end up either round, oval, square, or tubular depending on the number of increased crochet stitches and where you place them. Notice the variety of patterns and shapes in the motifs that follow. There are many patterns for working rounds.

The instructions below are for one method.

Abbreviation:

Rnd round

1. Ch 5 sts

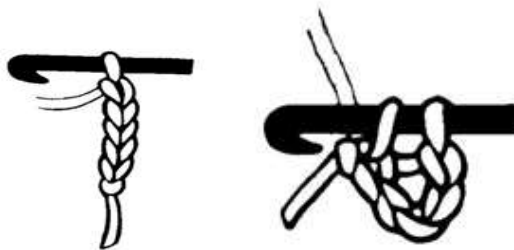

2. Insert hook in 5th chain from hook and slipstitch (sl st) to form a ring.



3. Ch 3 (counts as a dc st).



4. Dc in ring 17 times. (18 dc sts counting the ch 3.)

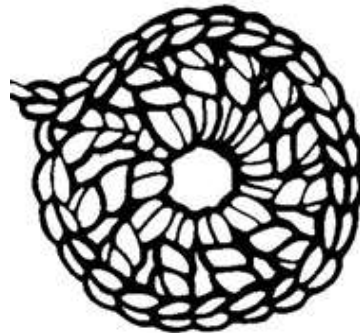

5. Join with sl st to top of ch 3.

Increasing Stitches

Increasing or decreasing the number of stitches in the rows create shaping in a project. Increasing adds width to the article while decreasing makes it narrower.

Increase (inc):

Increasing is very simple to do. It is done exactly in the same way with all the crochet stitches you have learned. You simply work 2 stitches in a single stitch of the previous row. Usually your pattern will tell you where to work the increase.

There may be several in the same row. Below is an illustration of a sc increase.

Decreasing Stitches

Decreasing can be made at any point on a row. Contrary to shaping by increasing, each basic stitch has a different method of decreasing. It is always important to follow the directions given in your pattern.

METHODS OF CLEANING

Dry cleaning

If the yarn label says dry clean, that is what must be done. Take a copy of the yarn label with the project to the dry cleaner to ensure proper cleaning. Disastrous results may be faced if a dry clean only article is washed.

Washing

Check the yarn label for washing and drying instructions. If it is safe to wash, follow guidelines recommended.

Hand washing - Wash gently in warm water with a mild detergent by squeezing water through the article. Rinse well in cold water.

Do not wring. Roll article in a bath towel to remove excess water. Lay flat on a towel to dry (put a plastic garbage bag under the towel to protect the drying surface). Gently pull into shape. Do not twist, stretch or hang.

Never iron articles made of synthetic yarn.

Machine washing do Machine wash using warm water and mild detergent.

Use a regular setting on the dryer to dry. Articles washed in a washing machine should always be dried in a dryer.

6.6 CHECK YOUR PROGRESS II

3. How to make a round crochet?

4. Write method of cleaning after crocheting.

6.7. MULTIPLE CHOICE QUESTIONS

1. Crochet is method of creating fabric by using a _____.

- (A) Hook (B) Frame
(C) Pen (D) Thimble

2. Find the meaning of the abbreviation of “ch”

- (A) Chain (B) Stitch
(C) Double chain (D) Single chain

3. Find the meaning of the abbreviation ‘dc’

- (A) Double chain (B) Direct crochet
(C) Direct chain (D) Double crochet

4. _____ use to hide loose end when joining yarn.

- (A) Yarn needle (B) Thread

- (C) Wool (D) Ribbon

5. _____ the number of stitches in the rows creates shaping in the crochet.

- (A) Slip crochets (B) Increasing and creasing
(C) Double crochets (D) Half double crochet

6.8. LET US SUM UP

In this unit, we learnt the process of crochet. Tools & Material required for crocheting were listed. We also discussed process of cleaning & washing. We learnt how to make chain stitch, loop stitch, and all other stitches of crocheting with abbreviations. We can use crochet for wall hanging, decoration accessories and garments their.

6.9 KEYWORDS

HOOK= a curved piece of metal, plastic, etc. that is use for crocheting.

BROOMSTICK= the handle of a broom

GAUGE RULER= a rule or line gauge use in measure or draw straight line.

SPLIT= to divide or to make a group of people divide into smaller groups.

CRUCIAL= extremely important

KNOT= a place where two ends or pieces of rope, string, etc. have been tied together

LOOP= a curved or round shape made by line curving round and joining or crossing itself.

RAVELLING= a thread from a woven or knitted fabric that has frayed or started to unravel.

FUZZY= not clear

INCREASE= to become or to make something larger in number or amount.

DECREASE= to become or to make something smaller or less.

6.10 SUGGESTED BOOKS

1. The Complete Guide Of Needle Work

2. A To Z Of Crochet-The Complete Guide-2007

3. The Crochet Stitch Bible- Betty Barnden

4. Around The Corner crochet Borders- Edie Ekman

{ Note: Figures Are Adapted From Suggested Book List And Source Of Non-

6.11 ANSWER

1. What is a crochet work?

Crochet is a method of creating fabric from yarn or thread, by using a hook and a ball of yarn. The word crochet comes from the old French word “crouches” or “croc” meaning hook. Originated in France during the 16th century, crochet was used as a simple method of making lace. It was

especially popular during the early part of the 20th century as edgings for linen tablecloths and petticoats. Today crochet remains an important needle art as it swings in and out of fashion prominence. One of the reasons it continues to be popular is, it requires very few equipment and little time. With different kinds and textures of yarn available, it is easy to create many beautiful and useful crocheted items

2. Write any three tools for crochet.

Hooks: Commonly made from plastic, aluminium, steel, or wood are available in many sizes. Some are as fine as a pin head. Others are as fat as a broomstick.

Yarn needle: Made of plastic or metal with a blunt point and large eye. It is used to hide loose ends when joining yarn or when project is finished.

Gauge ruler: A 2-inch L shaped window item that allows you to measure the number of stitches and rows in an inch.

3. How to make a round crochet?

A round is the name given to crochet that is worked in a continuous circle not

Turned from front to back as in rows. All motifs start as rounds or circles but may

End up either round, oval, square, or tubular depending on the number of increased crochet stitches and where you place them. Notice the variety of patterns and shapes in the motifs that follow. There are many patterns for working rounds.

The instructions below are for one method.

Abbreviation:

Rnd round

1. Ch 5 sts.
2. Insert hook in 5th chain from hook and slipstitch (sl st) to form a ring.
3. Ch 3 (counts as a dc st).
4. Dc in ring 17 times. (18 dc sts counting the ch 3.)
5. Join with sl st to top of ch 3

4. Write method of cleaning after crocheting.

METHODS OF CLEANING

Dry cleaning

If the yarn label says dry clean, that is what must be done. Take a copy of the yarn label with the project to the dry cleaner to ensure proper cleaning. Disastrous results may be faced if a dry clean only article is washed.

Washing

Check the yarn label for washing and drying instructions. If it is safe to wash,

Follow guidelines recommended.

Hand washing - Wash gently in warm water with a mild detergent by squeezing water through the article. Rinse well in cold water.

Do not wring. Roll article in a bath towel to remove excess water. Lay flat on a towel to dry (put a plastic garbage bag under the towel to protect the drying surface). Gently pull into shape. Do not twist, stretch or hang.

Never iron articles made of synthetic yarn.

Machine washing do machine wash using warm water and mild detergent. Use a regular setting on the dryer to dry. Articles washed in a washing machine should always be dried in a dryer. Never iron articles made of synthetic yarn.

MCQ ANSWER

- 1. Hook**
- 2. Chain**
- 3. Double Crochet**
- 4. Yarn Needle**
- 5. Increase And Decrease**

TIE & DYE

7.0 OBJECTIVES**7.1 INTRODUCTION****7.2 TYPES OF DESIGN TECHNIQUES****7.3 TOOLS AND MATERIALS****7.4. CHECK YOUR PROGRESS I****7.5 METHOD****7.6 CHECK YOUR PROGRESS II****7.7 MULTIPLE CHOICE QUESTIONS****7.8 LET US SUM UP****7.9 KEYWORDS****7.10 SUGGESTED BOOKS****7.11 ANSWER**

7.0 OBJECTIVES

- To gain an understanding of the process of tie & dye.
- To gain knowledge of tie & dye and its historical background.
- To become acquainted with dyes and other material required for tie & dye.

7.1 INTRODUCTION

Tie and dye is a resist-dyeing process for creating attractive coloured designs on fabrics.

This is achieved by knotting, binding, folding or sewing certain parts of the cloth in such a way that the dye cannot penetrate into these areas when the cloth is dyed. It is a hand process by which intricate and attractive patterns can be produced. In India, the tie dyeing method is generally a cottage

industry and is known as Bandhani or Bandhej. It is often used for T-shirts, dresses, skirts, and other garments and also in furnishings like pillow covers, table cloths, bed sheets etc. Tying the cloth or knotting is called bandhej or tie and dye. In this procedure the cloth is tied with a thread of thickness greater than that of the cloth. After the tied cloth is dyed and dried, the ties and knots are opened. As a result we get different colourful patterns on the cloth. The art of tie- dyeing is most popular in various regions of Gujarat, and Rajasthan.

7.2 TYPES OF DESIGN TECHNIQUES

1. Spot technique



-

(fig.1. spot technique)

- Pick the centred part of fabric with needle.
- Wrap sewing thread around directly below needle.
- Tie it tight, and remove the needle.
- Dip in dye, and remove the thread.

2. Circle technique

- Pick up centre of circle and smooth folds formed from it



(fig. 2. circle technique)

- Binding tight, and dip in to dye, radius of the circle is determined by the distance from the point to the bottom of the bindings.

3. Square Technique



(fig.3. square technique)

- Fold fabric lengthwise through centre, and fold crosswise.
 - Binding tight and dip into dye.

4. Pleated Oval:



(fig.4.pleated oval)

- Fold fabric in half along centre line of oval. Trace outline on fabric.
 - With fingers, pleat that oval shape together along this line, forming a fan shape, Binding, tie, and dip into dye.

5. Marbling



(fig. 5. marbling)

- Squash the fabric up into a ball, and bind in all directions until it is fairly hard.
- Dip into dye.

6. Ruching

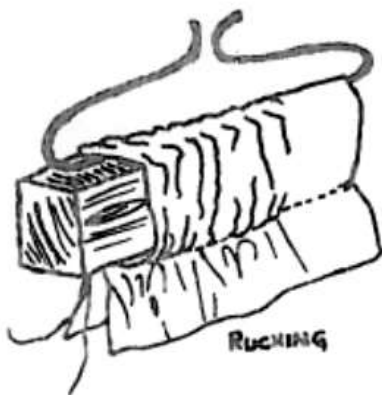

(fig. 6. Ruching)

- Fold the fabric along centre of stripe, and stitch a line by machine below fold, forming a casing, Slip casing over wood and gather all the fabric up at one end of the stick.
- Binding tight and dip into dye.
- Remove binding and machine stitching

7.3 TOOLS AND MATERIALS FOR TIE DYE

- **Fabric**

Suitable fabrics include cotton, burlap, silk, some rayon, linen and wool. Synthetic fabrics (nylon, polyester, acrylics) will not take a dye, so cannot be used.

Permanent press finish on cottons will not allow dye to penetrate so choose untreated



(fig. 7. cotton)

- **Cottons.**

Dye intensity is determined partly by the tightness of the twist of yarns in the fabric. For

Example, burlap with its loosely twisted yarns dyes much more brilliantly than tightly twisted broad cloth.

Wash the fabric first to avoid sizing issues. If left in, the sizing or starch will prevent the dye from fabric.

- **Bindings**



(fig.8.binding)

String, twine, cord, thread, and elastic bands can be used as binders. The finer the cord, the more lacy and delicate lines are produced.

- **Dyes**

Household dyes are satisfactory. They must be mixed stronger than the directions.

Generally for brilliant colours use one package dye to four cups boiling water.

Newspapers (to protect the floor or work surface)

Wear old clothes, an old apron. or large garbage bag to protect clothes. Rags, Carbon paper, Stove, Frame, Brushes, Blocks, Iron, Bowls, Tubs or bucket, Spoons, Rubber gloves, Salt - common salt, Caustic soda, Turkey red oil, Colours

7.4. CHECK YOUR PROGRESS I

1. WHAT IS TIE DYE?

2. WRITE ANY THREE TECHNIQUE OF BINDING.

7.5. METHOD

Follow these methods for tie-dye:

1- banding tight as per design and make a sample ready to dye.



(fig.9. method of tie)

2- Soften the water by boiling it

Proportion of dye



(fig.10.method of dye)

Fabric = 1 meter

Naphthol AT or BS = 1/8 tola (1 tola =10gms.)

Salt = ¼ tola

Common salt = 2 tablespoons.

Caustic soda = 5 to 6 (size like small grain)

1. Soak the fabric in chilled water, for a few minutes. Meantime prepare a dye solution , For example take naphthol 1/8 tola and add to it 3 to 4 tablespoons of soft water, make a fine paste.



(fig.11. tie dye)

2. Add 1 cup of water, and boil it for 12minutes, then add caustic soda, and remove it from fire.
3. Take ¼ bucket of soft water add solution and mix well, remove the fabric from water, open up the fabric well and dip in the prepare solution, mix well. Leave the fabric from solution.
4. In the meantime prepare the salt solution, to this add ¼ bucket of soft water and 2 tablespoon of common salt and mix well.
5. Remove fabric from naphthol solution and dip it in the salt solution, rinse fabric in plain cold water to remove excess colour, remove from water, press and dry.
6. Wash the fabric in hot water. Open binding. Untie and dry..

7. Some dye colour solution formulas
8. Naphthol AT + Black K Salt – Magenta
9. Naphthol AT + Yellow GL Salt – Yellow
10. Naphthol AT + Red B Salt –Orange
11. Naphthol AT + Blue B Salt - Brown

7.6. CHECK YOUR PROGRESS II

3. WRITE DOWN THE LIST OF TOOLS FOR TIE DYE.

4. EXPLAIN THE METHOD OF TIE DYE WORK.

7.7. MULTIPLE CHOICE QUESTIONS

1. Tie and Dye is known as a _____.
 (A) Patola (B) Bandhni
 (C) Chola (D) Malmal

2. Tie and Dye is popular in various regions of _____ - & _____.
 (A) Gujarat & Rajasthan (B) Maharashtra & Karnataka
 (C) Assam & Uttar Pradesh (D) Punjab & Jammu

3. Wrap sewing thread around direct below needle is _____ Technique.
 (A) Spot (B) Ruching
 (C) Square (D) Circle

4. _____ is use for Binding process.

- (A) Cord (B) Wax
(C) Naphthol (D) Caustic Soda

5. Naphthol At + Black K set - _____.

- (A) Magenta (B) Yellow
(C) Orange (D) Brown

7.8 LET US SUM UP

In this unit, we learnt about the details of tie-and-dye, The dyes used are then very briefly considered about the details of steps involved in tie-dyeing. Finally, the materials and equipment required for tie-dyeing are listed. We learnt the methods and process of tie & dye.

7.9. KEYWORDS

1. KNOTTING= fasten, tie, gird, truss
2. BINDING=bind, involving an obligation that cannot be broken, unbreakable
3. PENETRATE= go into or through something with force, stick, puncture
4. REGIONS= an area, a place
5. SPOT= mark, patch, pop, dot, stain
6. WRAP= swaddle, enfold, roll, conceal
7. RADIUS=the length of a line segment between the centre and circumference of a circle.
8. FORMING= fabricate, manufacture, produce, build, raise
9. BROADCLOTH= large fabric width
10. STRING= material consisting of threads of cotton or other fabric twisted together from
A thin length, cord, yarn, stands
11. TWINE= strong thread, cord, yarn
12. CORD= yarn, thread
13. FINER= acceptably, adequately, nicely, little
14. RAGS= a piece of old cloth, scrap of cloth
15. NAPHTHOL= an isomer of naphthol used in dyes
16. CAUSTIC SODA= sodium hydroxide
17. TOLA= a unit of weight in India
18. RINSE=wash, remove soap, clean
19. FORMULA= a mathematical relationship

7.10. SUGGESTED BOOKS

1. Batik And Tie Dye Technique By Niney Belfer
2. Tie-Dye: Dye It, Wear It, Share IT-shabd Simon- Alexander
3. Tie-Dye 101: How To Make Over 20 Fabulous Pattern-Sulfate Harries And Suzanne McNeil

{ Note: Figures Are Adapted From Suggested Book List And Source Of Non-Copyrighted Materials }

7.11. ANSWER

1. WHAT IS TIE DYE?

Tie and Dye is a resist-dyeing process for creating attractive coloured designs on fabrics.

This is achieved by knotting, binding, folding or sewing certain parts of the cloth in such a way that the dye cannot penetrate into these areas when the cloth is dyed. It is a hand process by which intricate and attractive patterns can be produced. In India, the tie dyeing method is generally a cottage industry and is known as Bandhani or Bandhej. It is often used for T-shirts, dresses, skirts, and other garments and also in furnishings like pillow covers, table cloths, bed sheets etc. Tying the cloth or knotting is called bandhej or tie and dye. In this procedure the cloth is tied with a thread of thickness greater than that of the cloth. After the tied cloth is dyed and dried, the ties and knots are opened. As a result we get different colourful patterns on the cloth. The art of tie- dyeing is most popular in various regions of Gujarat, and Rajasthan.

2. WRITE ANY 3 TECHNIQUE OF BINDING.

1. Spot technique

- Pick the centred part of fabric with needle.
- Wrap sewing thread around directly below needle.
- Tie it tight, and remove the needle.
- Dip in dye, and remove the thread.

2. Circle technique

- Pick up centre of circle and smooth folds formed from it.
 - Binding tight, and dip in to dye, radius of the circle is determined by the distance from the point to the bottom of the bindings.

3. Square Technique

- Fold fabric lengthwise through centre, and fold crosswise.
 - Binding tight and dip into dye.

3. WRITE TOOLS LIST OF TIE DYE.

- **Fabric**

Suitable fabrics include cotton, burlap, silk, some rayon, linen and wool. Synthetic fabrics (nylon, polyester, acrylics) will not take a dye, so cannot be used.

Permanent press finish on cottons will not allow dye to penetrate so choose untreated

- **Cottons.**

Dye intensity is determined partly by the tightness of the twist of yarns in the fabric. For

Example, burlap with its loosely twisted yarns dyes much more brilliantly than tightly twisted

broad cloth. Wash the fabric first to avoid sizing issues. If left in, the sizing or starch will prevent the dye from

- **Bindings**

String, twine, cord, thread, and elastic bands can be used as binders.

The finer the cord, the more lacy and delicate lines are produced.

- **Dyes**

Household dyes are satisfactory. They must be mixed stronger than the directions.

Generally for brilliant colours use one package dye to four cups boiling water.

Newspapers (to protect the floor or work surface)

Rubber gloves

Wear old clothes, an old apron. or large garbage bag to protect clothes.

Rags (for cleaning up)

4. WRITE METHOD OF TIE DYE WORK.

Follow these methods for tie-dye

1 -banding tight as per design and make a samples ready to dye.

2-Soften the water by boiling it

Proportion of dye

Fabric = 1 meter

Naphthol AT or BS = 1/8 tola (1 tola =10gms.)

Salt = ¼ tola

Common salt = 2 tablespoons.

Caustic soda = 5 to 6 (size like small grain)

1. Soak the fabric in very chilled water, for a few minutes. Meantime prepare a dye solution, for example take naphthol 1/8 tola and add to it 3 to 4 tablespoons of soft water, make a fine paste.
2. Add 1 cup of water, and boil it for 12minutes, then add caustic soda, and remove it from fire.
3. Take ¼ bucket of soft water add solution and mix well, remove the fabric from water, open up the fabric well and dip in the prepare solution, mix well. Leave the fabric from solution.
4. In the meantime prepare the salt solution, to this add ¼ bucket of soft water and 2 tablespoon of common salt and mix well.
5. Remove fabric from naphthol solution and dip it in the salt solution, rinse the fabric in plain cold water to remove excess colour, remove from water, press and dry.

6. Wash the fabric in to hot water and detergent. Open binding. Untie and dry..
7. Some dye colour solution formulas
8. Napthol AT + Black K Salt – Magenta
9. Napthol AT + Yellow GL Salt – Yellow
10. Napthol AT + Red B Salt –Orange
11. Napthol AT + Blue B Salt - Brown

MCQ ANSWER

- 1. Bandhni**
- 2. Gujarat And Rajasthan**
- 3. Spot**
- 4. Cord**
- 5. Magenta**

યુનિવર્સિટી ગીત

સ્વાધ્યાય: પરમં તપ:

સ્વાધ્યાય: પરમં તપ:

સ્વાધ્યાય: પરમં તપ:

શિક્ષણ, સંસ્કૃતિ, સદ્ભાવ, દિવ્યબોધનું ધામ
ડૉ. બાબાસાહેબ આંબેડકર ઓપન યુનિવર્સિટી નામ;
સૌને સૌની પાંખ મળે, ને સૌને સૌનું આભ,
દશે દિશામાં સ્મિત વહે હો દશે દિશે શુભ-લાભ.

અભણ રહી અજ્ઞાનના શાને, અંધકારને પીવો ?
કહે બુદ્ધ આંબેડકર કહે, તું થા તારો દીવો;
શારદીય અજવાળા પહોંચ્યાં ગુર્જર ગામે ગામ
ધ્રુવ તારકની જેમ ઝળહળે એકલવ્યની શાન.

સરસ્વતીના મયૂર તમારે ફળિયે આવી ગહેકે
અંધકારને હડસેલીને ઉજાસના ફૂલ મહેંકે;
બંધન નહીં કો સ્થાન સમયના જવું ન ઘરથી દૂર
ઘર આવી મા હરે શારદા દૈન્ય તિમિરના પૂર.

સંસ્કારોની સુગંધ મહેંકે, મન મંદિરને ધામે
સુખની ટપાલ પહોંચે સૌને પોતાને સરનામે;
સમાજ કેરે દરિયે હાંકી શિક્ષણ કેરું વહાણ,
આવો કરીયે આપણ સૌ
ભવ્ય રાષ્ટ્ર નિર્માણ...
દિવ્ય રાષ્ટ્ર નિર્માણ...
ભવ્ય રાષ્ટ્ર નિર્માણ



**CERTIFICATE IN
FASHION DESIGNING
SURFACE ORNAMENTATION
CFD-03**

Message for the Students

Dr. Babasaheb Ambedkar Open (University is the only state Open University, established by the Government of Gujarat by the Act No. 14 of 1994 passed by the Gujarat State Legislature; in the memory of the creator of Indian Constitution and Bharat Ratna Dr. Babasaheb Ambedkar. We Stand at the seventh position in terms of establishment of the Open Universities in the country. The University provides as many as 54 courses including various Certificate, Diploma, UG, PG as well as Doctoral to strengthen Higher Education across the state.



On the occasion of the birth anniversary of Babasaheb Ambedkar, the Gujarat government secured a quiet place with the latest convenience for University, and created a building with all the modern amenities named 'Jyotirmay' Parisar. The Board of Management of the University has greatly contributed to the making of the University and will continue to this by all the means.

Education is the perceived capital investment. Education can contribute more to improving the quality of the people. Here I remember the educational philosophy laid down by Shri Swami Vivekananda:

“We want the education by which the character is formed, strength of mind is increased, the intellect is expand and by which one can stand on one’s own feet”.

In order to provide students with qualitative, skill and life oriented education at their threshold. Dr. Babaasaheb Ambedkar Open University is dedicated to this very manifestation of education. The university is incessantly working to provide higher education to the wider mass across the state of Gujarat and prepare them to face day to day challenges and lead their lives with all the capacity for the upliftment of the society in general and the nation in particular.

The university following the core motto ‘स्वाध्यायः परमम् तपः’ does believe in offering enriched curriculum to the student. The university has come up with lucid material for the better understanding of the students in their concerned subject. With this, the university has widened scope for those students who are not able to continue with their education in regular/conventional mode. In every subject a dedicated term for Self Learning Material comprising of Programme advisory committee members, content writers and content and language reviewers has been formed to cater the needs of the students.

Matching with the pace of the digital world, the university has its own digital platform Omkar-e to provide education through ICT. Very soon, the University going to offer new online Certificate and Diploma programme on various subjects like Yoga, Naturopathy, and Indian Classical Dance etc. would be available as elective also.

With all these efforts, Dr. Babasaheb Ambedkar Open University is in the process of being core centre of Knowledge and Education and we invite you to join hands to this pious *Yajna* and bring the dreams of Dr. Babasaheb Ambedkar of Harmonious Society come true.



Prof. Ami Upadhyay
Vice Chancellor,
Dr. Babasaheb Ambedkar Open University,
Ahmedabad.

Editor

Prof. (Dr.) Ami Upadhyay
Vice Chancellor
Dr. Babasaheb Ambedkar Open University, Ahmedabad
Dr. Awa Shukla
Assistant Professor (Subject Head)/ Director (I/c) Student Services
Dr. Babasaheb Ambedkar Open University, Ahmedabad

Programme Advisory Committee

Prof. (Dr.) Ami Upadhyay
Vice Chancellor
Dr. Babasaheb Ambedkar Open University, Ahmedabad
Dr. Awa Shukla
Assistant Professor (Subject Head)/ Director (I/c) Student Services
Dr. Babasaheb Ambedkar Open University, Ahmedabad
Dr. Rajshree Yadav
Prof. (CACDDM)
Government Girls College, Ahmedabad
Dr. Hemalata Patel
Prof. (Home-Science)
Mahila Home-Science College, Mahesana
Ms. Devyani Dhandhukiya
Fashion Designer & Freelancer, Ahmedabad

Reviewers

Dr. Rajshree Yadav
Prof. (CACDDM)
Government Girls College, Ahmedabad
Dr. Hemalata Patel
Prof. (Home-Science)
Mahila Home-Science College, Mahesana

Content Writers

Ms. Devyani Dhandhukiya

Programme Coordinator

Dr. Awa Shukla
Director (I/c) Student Services
Dr. Babasaheb Ambedkar Open University, Ahmedabad

Publisher

Dr. Bhavin Trivedi
Registrar (I/c), Dr. Babasaheb Ambedkar Open University, Ahmedabad

Copyright © Dr. Babasaheb Ambedkar Open University – Ahmedabad. June 2020



This publication is made available under a Creative Commons

Attribution-NonCommercial-ShareAlike 4.0 International
(CC BY-NC-SA 4.0)

<https://creativecommons.org/licenses/by-nc-sa/4.0/>

ISBN-978-93-89456-74-5

All rights reserved. No part of this work may be reproduced in any form, by mimeograph or any other means without permission in writing from Dr. Babasaheb Ambedkar Open University, Ahmedabad. While all efforts have been made by editors to check accuracy of the content, the representation of facts, principles, descriptions and methods are that of the respective module writers. Views expressed in the publication are that of the authors, and do not necessarily reflect the views of Dr. Babasaheb Ambedkar Open University. All products and services mentioned are owned by their respective copyright holders, and mere presentation in the publication does not mean endorsement by Dr. Babasaheb Ambedkar Open University. Every effort has been made to acknowledge and attribute all sources of information used in preparation of this learning material. Readers are requested to kindly notify missing attribution, if any.



Dr. Babsaheb Ambedkar Open University
(Established by Government of Gujarat)

CERTIFICATE IN FASHION
DESIGNING SURFACE ORNAMENTATION
CFD-03

Block

2

Unit 8

Batik

Unit 9

Hand Painting

Unit 10

Printing

Unit 11

Ribbon Work

Unit 12

Bead & Sequin Work

Unit 13

Aari & Zardozi Work

Unit 14

Quilting

UNIT: 8

BATIK

8.0 OBJECTIVES**8.1 INTRODUCTION****8.2 TYPES OF DESIGN****8.3 TOOLS AND MATERIALS****8.4. CHECK YOUR PROGRESS I****8.5 METHOD****8.6 CHECK YOUR PROGRESS II****8.7 MULTIPLE CHOICE QUESTIONS****8.8 LET US SUM UP****8.9 KEYWORDS****8.10 SUGGESTED BOOKS****8.11 ANSWER**

8.0 OBJECTIVES

- To gain an understanding of batik work.
- To gain understanding of the different material required for making batik work
- To briefly understand the process of making batik work.

8.1 INTRODUCTION

Batik is a technique of decorating the surface of cloth by covering the part of it with wax and then dyeing the cloth. The waxed areas keep their original colour and when the wax is removed the contrast between the dyed and undyed area gives pretty look. "The word batik originates from the Javanese tic means a dot." Wax is applied to sections of the material which are to remain uncoloured. When the waxed fabric is dipped in the dye, the wax resists the entry of the dye into the fabric, only the un-waxed portions get coloured as the dyes do not penetrate wax. Once dyed, the wax can be removed by various methods, one of those methods is boiling. The lines in batiks are produced by cracking the hardened wax before applying the dye.

8.2 TYPES OF DESIGN

Several types of design used for batik are...

1. Design by Hand:

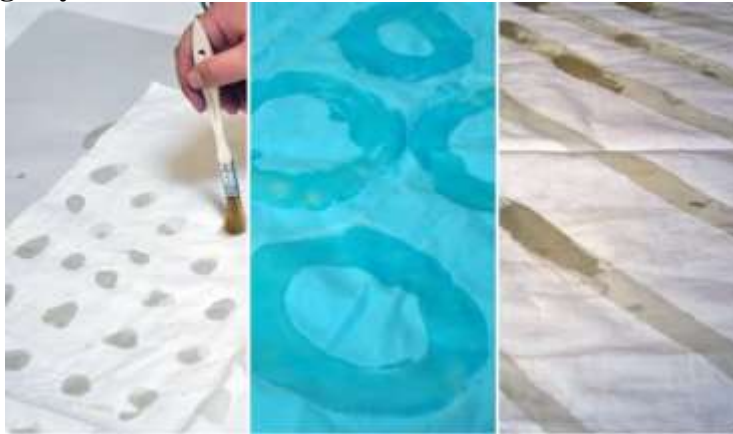

(fig 1. design by hand)

Batiking is a simple technique where melted wax is applied with a brush or other applicator on fabric design should be natural object or geometric shape or anything that applicator done with hand.

2. Design by Marbling:

Marbling is a technique where wax is dropped on a prepared bath that allows the dyes to float on the surface.

3. Design by Stencil:



(fig.2.design by stencil)

Stencil is a technique where wax is applied in carved or cut shape. Ex.geometric shapes

4. Design by Tie-dye:

Tie-dye is a resist technique where fabric is tied with cord or band before wax or dye is applied.

5. Design by Block printing:



(fig.3.design by block printing)

Block printing is a technique where wax is applied on wooden carved block. Design is made by using various designs of blocks.

8.3 TOOLS AND MATERIALS

Some tools and materials required for batik are...

1. Wax: Waxes like premixed wax, soy wax, beeswax, sticky wax or paraffin waxes.
2. Pencil: Sharp pencil for making design by hand.
3. Tracing paper: Tracing paper is require for trace the design on paper for making stencil or blocks.
4. Carbon paper: Carbon paper is requiring tracing design on fabric for applying the wax.
5. Stove: Stoves require for boiling the wax.
6. Frame: Frame is requiring fitting the fabric while applying wax.
7. Brushes of different numbers: Brushes are required to apply
8. Blocks: Wooden carved bocks for wax block printing
9. Iron: Iron for press the design
10. Bowls - Plastic or enamel plated bowls for mixing colour
11. Tubs or bucket for dyeing fabric
12. Spoons to measure and mix colour for dyeing
13. Rubber gloves: for protecting hand from dyes colour.
14. Salt - Common salt
15. Caustic soda
16. Turkey red oil - Used as wetting agent for naphthol powder
17. Colours - Special colours are used for batik.

8.4. CHECK YOUR PROGRESS I

1. What is Batik?

2. Write a short note about tools and material uses for batik work.

8.5 METHOD

Following are a few methods for batik work.

- trace an ideal design on sheet or paper
- place the design on fabric, once designs traced on the fabric apply the melted wax on areas which are supposed to resist colour. Bee wax and paraffin wax are used in 1:2 proportions.

the fabric is dyed using the following steps:

1. Soften the water by boiling it
2. Proportion of dye
3. Fabric = 1 meter
4. Naphthol AT or BS = 1/8 tola (1 tola =10gms.)
5. Salt = ¼ tola
6. Common salt = 2 tablespoons.
7. Caustic soda = 5 to 6 (size like small grain)
8. Soak the waxed fabric in very cold water, for a few minutes. in meantime prepare dye solution , for example take naphthol 1/8 tola and add to it 3 to 4 tablespoons of soft water, make a fine paste.
9. Add 1 cup of water, and boil it for 12minutes, than add caustic soda, and remove it from fire.
10. Take ¼ bucket of soft water add solution and mix well, remove fabric from water, open up the fabric well and dip in the prepare solution, mix well. Leave the fabric from solution.
11. In the meantime prepare the salt solution, to this add ¼ bucket of soft water and 2 tablespoon of common salt and mix well.
12. Remove fabric from naphthol solution and dip it in the salt solution, rinse fabric in plain cold water to remove excess colour, remove from water, press and dry.
13. DE waxing- wash the fabric in to hot water and detergent, once dry place it between 2 sheets of paper or newspaper, iron with very hot iron. The paper will absorb the wax.
14. Some dye colour solution formulas
15. Naphthol AT + Black K Salt – Magenta
16. Naphthol AT + Yellow GL Salt – Yellow
17. Naphthol AT + Red B Salt –Orange
18. Naphthol AT + Blue B Salt - Brown

8.6. CHECK YOUR PROGRESS II

3. Write any 2 types of batik technique.

4.write a short note about method of batik.

9. MARBLING= blot, marble, mottle, soil, tarnish, or splash
10. ENAMEL= coating, gaze, stain, varnish, polish
11. RINSE= bath, clean, dip, flush, soak, wash, wet, cleanse, water

8.10 SUGGESTED BOOKS

1. Batik And Tie Dye Technique By Niney Belfer
 2. Creative Batik By Rosi Robinson
 3. Batik, Traditional Textiles- Donald Harper
 4. The Book Of Batik By Fiona Kerlogue
- { Note: Figures Are Adapted From Suggested Book List And Source Of Non-Copyrighted Materials }

8.11 ANSWER

1. What is Batik?

= Batik is a technique of decorating the surface of cloth by covering the part of it with wax and then dyeing the cloth. The waxed areas keep their original colour and when the wax is removed the contrast between the dyed and undyed area gives pretty look .the word batik originate from the Javanese tik means a dot.

2. Write a short note about tools and materiel uses for batik work.

Some tools and materials required for batik are...

1. Wax: waxes like premixed wax, soy wax, beeswax, sticky wax or paraffin waxes.
2. Pencil: Sharp pencil for making design by hand.
3. Tracing paper: Tracing paper is require for trace the design on paper for making stencil or blocks.
4. Carbon paper: Carbon paper is require to trace design on fabric for applying the wax.
5. Stove: Stoves require for boiling the wax.
6. Frame: Frame is require to fitted the fabric while applying wax.
7. Brushes of different numbers: Brushes are required to apply.
8. Blocks: Wooden carved bocks for wax block printing
9. Iron (Press): Iron for press the design
10. Bowls - Plastic or enamel plated bowls for mixing colour
11. Tubs or bucket for dyeing fabric
12. Spoons to measure and mix colour for dyeing
13. Rubber gloves: Rubber gloves for protecting hand from dyes colour.
14. Salt - Common salt
15. Caustic soda
16. Turkey red oil - Used as wetting agent for naphthol powder
17. Colours - Special colours are used for batik.

3. Write any 2 types of batik technique.

1. Design by Hand:

Batiking is a simple technique where melted wax is applied with a brush or other applicator

on fabric design should be natural object or geometric shape or anything that applicator done with hand.

2. Design by Marbling:

Marbling is a technique where wax is dropped on a prepared bath that allows the dyes to float on the surface.

4. Write a short note about method of batik.

Following are a few methods for batik work.

- trace an ideal design on sheet or paper
- place the design on fabric, once designs traced on the fabric apply the melted wax on areas
- which are supposed to resist colour. Bee wax and paraffin wax are used in 1:2 proportion.

the fabric is dyed using the following steps:

1. Soften the water by boiling it
2. Proportion of dye
3. Fabric = 1 meter
4. Naphthol AT or BS = 1/8 tola (1 tola =10gms.)
5. Salt = ¼ tola
6. Common salt = 2 tablespoons.
7. Caustic soda = 5 to 6 (size like small grain)
8. Soak the waxed fabric in very cold water, for a few minutes. in meantime prepare dye solution , for example take naphthol 1/8 tola and add to it 3 to 4 tablespoons of soft water, make a fine paste.
9. Add 1 cup of water, and boil it for 12minutes, than add caustic soda, and remove it from fire.
10. Take ¼ bucket of soft water add solution and mix well, remove fabric from water, open up the fabric well and dip in the prepare solution, mix well. Leave the fabric from solution.
11. In the meantime prepare the salt solution, to this add ¼ bucket of soft water and 2 tablespoon of common salt and mix well.
12. Remove fabric from naphthol solution and dip it in the salt solution, rinse fabric in plain cold water to remove excess colour, remove from water, press and dry.
13. DE waxing- wash the fabric in to hot water and detergent, once dry place it between 2 sheets of paper or newspaper, iron with very hot iron. The paper will absorb the wax.
14. Some dye colour solution formulas
15. Naphthol AT + Black K Salt – Magenta
16. Naphthol AT + Yellow GL Salt – Yellow
17. Naphthol AT + Red B Salt –Orange
18. Naphthol AT + Blue B Salt - Brown

MCQ ANSWER

- 1. Wax**
- 2. Dot**
- 3. Rubber Gloves**
- 4. Tie-Dye**
- 5. Turkey Red Oil**

UNIT: 9

HAND PAINTING

9.0 OBJECTIVES**9.1 INTRODUCTION****9.2 TOOLS AND MATERIALS****9.3 TRANSFERRING DESIGN ON FABRIC****9.4 CHECK YOUR PROGRESS I****9.5. METHOD****9.6 CHECK YOUR PROGRESS II****9.7 MULTIPLE CHOICE QUESTIONS****9.8 LET US SUM UP****9.9 KEYWORDS****9.10. SUGESSTED BOOKS****9.11. ANSWER**

9.0 OBJECTIVES

- To gain knowledge about hand painting.
- To understand different kinds of brushes are required for hand painting and ways to take care of them.
- To understand about different methods of transferring the designs on fabric.

9.1 INTRODUCTION

The hand printing of fabric is an ancient craft date back as early as 4000 BC. Through time consuming Free hand painting of designs is probably the oldest technique of surface ornamentation. Fabric may be coloured with any medium that stick fast to it, but planning is necessary to decide which is the most suitable for colorfastness for dry cleaning.

Hand printing involves use of dye or pigment apply to textiles are wash fast when used on suitable fabric.

9.2 TOOLS AND MATERIALS

9.2.1 Fabric



(fig.1.fabric)

It is always better to start with cotton fabric which is re-sized. Thin and smooth fabric allows fabric colour to spread very fast. Whereas textural fabrics will not absorb colour quickly and allow creating novel effects. Textural fabrics such as georgette, denim, heavy upholstery fabrics are most suitable for dry strokes. Selection of suitable fabrics for various applications is most important.

9.2.2 Paints

Paints from any reputed company can be used. They are available in many forms like bottles or tubes which can be used directly and a few along with medium. They are applied using brushes.

- Regular colours: These are pure tones and tints of different colours.
- Pearl colours: These are colours that have pearl like luster.
- Metallic colours: They are metal based with the metallic dust incorporated.

9.2.3 Frame

Wooden/ Metal frame can be used to hold the fabric tight. Frame also helps to avoid the contact of fabric to the ground and thus let the full quantity of colour get absorbed inside the fabric.

9.2.4 Fabric Brushes

Brushes play a very important role in the process of hand painting. So it is important to learn how to choose right brushes. A right brush produces

good results. A brush that is too stiff can damage the fibres of the fabric. On the other hand, a brush that is too soft will cause frustration while applying paint. The most common type of brushes designed for fabrics are synthetic or nylon brushes. These brushes are specifically designed to be used on fabric and they come in a variety of styles. Fabric brushes are available in flat angles, pointed, rounds, liners and scrubbers. Flat angles, pointed, rounds and liners are used mainly for brush-on fabric Painting. They are used for finer woven or knitted fabrics such as cambric, silk and T shirt Type knits.

9.2.5 SIZES AND TYPES OF BRUSHES



(fig. 2. types of brushes)

Brushes come in different sizes. They are graded by number. Higher the number, larger the brush. For instance a size 2 brush is bigger than a size 1 brush. There are special brushes which are designed for intricate and delicate work. Fine brushes suitable for watercolour or acrylic painting can also be used. Brushes for oil colour painting tend to be large and flat and not much good for tiny areas of colour.

9.2.6 Buying A Brush

You can buy paint brushes from stationers, art suppliers etc. Try to find a shop that offers a good selection, so you can compare different types, and pick one that suits both your requirement and budget. Cheap brushes are made from artificial hair like nylon fibres. Brushes made from a hair/nylon mix, cost a little more. The best brushes, however, are real animal hair brushes, such as, sable, camel or squirrel. These brushes are also the most expensive ones. When you have found a range you like, pick out a few brushes of the size you want and compare them. Look for a brush that comes to a nice point, without any stray hairs coming out at unwanted angles. Good quality brushes are usually protected by a clear plastic guard. If you remove this guard to inspect the quality, remember to replace it carefully afterwards. It is worth spending a bit more on good quality

brushes, since they are easier to paint with. You must, however, look after them carefully; then they will last a long time.

9.2.7 Caring For Your Brushes.

When you are painting, do not dip the brush completely into the paint. It results in paint wastage and also old paint will clog up and spoil the base of the brush. Use the right brush for the job – if you are painting a large area of flat colour, do not use the detail brush (small size). Either set aside specific brushes for certain tasks, or keep a selection of old/cheap brushes for rough tasks. When you've finished painting, clean your brushes in clean water and store them safe. Do not leave the brush in water with the brush side dipped in water for long, else the tip gets spoilt.

Always store the brushes either in a cloth case as illustrated above or with the brush side up; possibly with the plastic guard on.

Even while intermissions during painting sessions; it is desirable to keep the brushes with the brush side up in the container.

While painting, pressure should not be applied on the brush tip, lest it would spoil the tip.

9.3 TRANSFERRING DESIGN ON FABRIC

FABRIC PREPARATION

Always pre-wash the fabric before paint, to remove any dirt, starch or Grease from the material. These agents do not allow the paint to penetrate into the Fabric or become permanent. Always iron the fabric to remove any wrinkles before transferring the design.

It is desirable to stretch and fix the fabric to a frame before starting to paint.

9.3.1 STENCILING



(fig.3.stencilling)

A method of applying a design by brushing or sponging paint through a cut-out Overlay placed on the surface Stencilling the design on the fabric is an easy way of achieving beautiful designs. Stencilling the design is painted with the help of brushes or sponges.

9.3.2 TRACING



(fig.4.tracing)

In this method, a design is first traced on a tracing sheet. Then with the help of a carbon paper the design is transferred onto a fabric. Dark fabrics are a little more difficult to transfer patterns on. You can use red or white carbon to trace on them.



(fig.5.tracing by carbon paper)

9.3.3 FREE HAND DRAWING

You can also draw designs directly on the fabric through the free hand method. For this, you must have a steady and practiced hand. After a design has been transferred on the fabric, the fabric will need to be positioned on a painting board. The Surface of the painting board should be smooth and nonporous. The painting board should be larger than the design area to prevent having to move the fabric around. The fabric is required to be secured to the board with the help of clips or masking tape.

9.4 CHECK YOUR PROGRESS I

1. What is hand painting?

2. provide list of tools and materials for hand painting.

9.5. METHOD

9.5.1 Wet brush technique

- Dip the round brush in water.
- Blot out excess water.
- Pick up a small amount of paint that is enough to blend.
- Blend it into the brush by stroking repeatedly over the same spot which helps in even distribution of paint.
- Now try painting a stroke, which may be dry.
- Repeat the steps to get a watery transparent stroke from start to finish.

9.5.2. Dry Brush Technique

- Take a round brush which is completely dry and wipe the brush hairs gently against a paper towel to remove excess paint.
- Make a stroke and it appears as if it is stranded and the paint diminishes gradually.
- Wipe the brush a little more on paper towel. Paint another stroke, which looks filmier.
- Repeat wiping till you get the required filmy stroke.

9.5.3 Tipping

- Load the round brush completely with one colour.
- Just dip the tip of the brush into second colour.
- Only a small amount of second colour is required.
- Give the stroke with a brush loaded with two colours.
- Tip the brush with two colours for a multi colour version.

9.5.4. Dot work

- Dip the wooden end of the paint brush in paint and stamp on the fabric to produce dots of decreasing/increasing size.
- Dipping a pencil eraser into paint produces a series of diminishing dots.
- Pin head can also be used to produce a line of small dots.

9.5.5 Comma Stroke

- Press the round full loaded brush to flatten out the hairs into a rounded shape.
- Pull the stroke into a gentle curve, releasing pressure as you pull.
- Slow down as the stroke tails off and lift the brush cleanly.
- The flat end of the stroke is referred as head and thin end as the tail.
- Practice to paint commas in all directions.

9.5.6 Marbling

This technique is used mainly on paper. But it can also be produced on fabric. Paints of different colours are poured on the surface of the water in a little shallow shaped trough. The colours are stirred slightly. Then the face of the fabric is made to come in contact with the fabric and the paints produce beautiful pattern on fabric.

TIPS FOR PAINT AND PREPARATION

- Water can also be used the medium for thinning the paint instead of chemical thinner.
- Paint consistency varies with the variety of fabrics. The paint should not be very thin i.e., dilute while painting on synthetic fabrics.

- It is desirable to apply more than two coats. In case of cotton, the consistency of the paint really does not matter much.
- The paint tends to thicken during painting, to avoid this, keep wetting the brush frequently and also add few drops of water and mix the paint.

9.6 CHECK YOUR PROGRESS II

3. Write any 3 method of hand painting.

4. Care and tips for hand painting.

9.7. MULTIPLE CHOICE QUESTIONS

- _____ of fabric is an ancient crafts date back as early as 4000 BC.
 (A) Ribbon (B) Quilling
 (C) Hand painting (D) printing
- _____ play a very important role in the process of hand painting.
 (A) Needle (B) brushes
 (C) Water (D) thread
- Design can be transferred on the fabric by using _____.
 (A) Carbon paper (B) Glue
 (C) Water (D) wax
- _____ is method of transferring design for hand painting.
 (A) Painting (B) printing
 (C) Quilling (D) stencil
- Hand painting is creative _____.
 (A) Sewing (B) Tool
 (C) Art (D) pattern

9.8 LET US SUM UP

In this unit, we learnt the definition of hand painting and material required for hand painting. We also discussed some tips on buying good quality brushes and caring for brushes. This unit also deals with fabric preparation for painting and design transfer

9.9 KEYWORDS

1. **ANCIENT:** Belonging to the very distant past and no longer in existence, early, past.
2. **PIGMENT:** A natural colouring matter of animal or plant tissue.
3. **RESEMBLE:** Look like, be similar to, remind one of, take after
4. **EMULTION:** A type of paint used for walls, consisting of pigment bound in synthetic resin which forms an emulsion with water.
5. **GOUCHE:** A method of painting using opaque pigments ground in water and thickened with glue like substance.

9.10. SUGGESTED BOOKS

1. Surface Deigning Of Textile Fabrics – Shailaja d. Naik, Jacquie a. Wilson
 2. Fabric Painting With Cindy Walter
 3. Fabric Of Life Textile Arts In Bhutan-Karin Altman
- { Note: Figures Are Adapted From Suggested Book List And Source Of Non-Copyrighted Materials }

9.11. ANSWER

1. What is hand painting?

The hand printing of fabric is an ancient craft date back as early as 4000 BC. Through time consuming Free hand painting of designs is probably the oldest technique of surface ornamentation. Fabric may be coloured with any medium that stick fast to it, but planning is necessary to decide which is the most suitable for colorfastness for dry cleaning.

Hand printing involves use of dye or pigment apply to textiles are wash fast when used on suitable fabric.

2. Write a list of Tools and materials for hand painting.

1. Fabric:-

It is always better to start with cotton fabric which is re-sized. Thin and smooth fabric allows fabric colour to spread very fast. Whereas textural fabrics will not absorb colour quickly and allow creating novel effects. Textural fabrics such as georgette, denim, gabardine, heavy upholstery fabrics are most suitable for dry strokes. Selection of suitable fabrics for various applications is most important.

2. Paints:-

Paints from any reputed company can be used. They are available in many forms like bottles or tubes which can be used directly and few along with medium. They are applied using brushes.

- Regular colours: These are pure tones and tints of different colours.
- Pearl colours: These are colours that have pearl like luster.
- Metallic colours: They are metal based with the metallic dust incorporated.

3. Frames:-

Wooden/ Metal frame can be used to hold the fabric tight. Frame also helps to avoid the

Contact of fabric to the ground and thus let the full quantity of colour get absorbed

Inside the fabric.

4. Fabric brushes:-

Brushes play a very important role in the process of hand painting. So it is Important to learn how to choose right brushes. A right brush produces good results. A brush that is too stiff can damage the fibres of the fabric. On the other hand, a brush that is too soft will cause frustration while applying paint. The most common type of brushes designed for fabrics are synthetic or nylon brushes. These brushes are specifically designed to be used on fabric and they come in a variety of styles. Fabric brushes are available in flat angles, pointed, rounds, liners and scrubbers. Flat angles, pointed, rounds and liners are used mainly for brush-on fabric

Painting. They are used for finer woven or knitted fabrics such as cambric, silk and T-shirt

Type knits.

3. Write any three method of hand painting.

1. Wet brush technique:-

- Dip the round brush in water.
- Blot out excess water.
- Pick up a small amount of paint that is enough to blend.
- Blend it into the brush by stroking repeatedly over the same spot which helps in even distribution of paint.
- Now try painting a stroke, which may be dry.
- Repeat the steps to get a watery transparent stroke from start to finish.

2. Dry Brush Technique:-

- Take a round brush which is completely dry and wipe the brush hairs Gently against a paper towel to remove excess paint.
- Make a stroke and it appears as if it is stranded and the paint diminishes Gradually.
- Wipe the brush a little more on paper towel. Paint another stroke, This looks filmier.
- Repeat wiping till you get the required filmy stroke.

3. Tipping

- Load the round brush completely with one colour.
- Just dip the tip of the brush into second colour.

- Only a small amount of second colour is required.
- Give the stroke with a brush loaded with two colours.
- Tip the brush with two colours for a multi colour version.

4. Care and tips for hand painting.

TIPS FOR PAINT AND PREPARATION

- Water can also be used the medium for thinning the paint instead of chemical thinner.
- Paint consistency varies with the variety of fabrics. The paint should not be very thin i.e., dilute while painting on synthetic fabrics.
- It is desirable to apply more than two coats. In case of cotton, the consistency of the paint really does not matter much.
- The paint tends to thicken during painting, to avoid this, keep wetting the brush frequently and also add few drops of water and mix the paint.

MCQ ANSWER

- 1. Hand Painting**
- 2. Brushes**
- 3. Carbon Paper**
- 4. Stencil**
- 5. Art**

UNIT: 10

PRINTING

10.0 OBJECTIVES**10.1 INTRODUCTION****10.2 STYLE OF PRINTING****10.3 CHECK YOUR PROGRESS I****10.4. METHOD OF PRINTING****10.5 CHECK YOUR PROGRESS II****10.6 MULTIPLE CHOICE QUESTIONS****10.7 LET US SUM UP****10.8 KEYWORDS****10.9 .SUGGESTED BOOKS****10.10. ANSWER**

10.0 OBJECTIVES

- To gain knowledge about printing
- To learn different style of printing
- To learn variations of printing

10.1 INTRODUCTION

The application of a pattern on to fabric by the use of dyes, pigments, or other colourize substances was influenced by a variety of hand and machine process. Here the design is transferred on a flat subtract, using a device coated with the dye, by simply stamping on the fabric. The same design is repeated many a times across the fabric by pressing this decorated coloured surface against the fabric, which is nothing but printing.

Printing is an art, many be defined as localized dying which in turn produces designs of numerous innovative ideas and thoughts. Over many centuries, a variety of techniques for printing having been evolved. Printing can be applied to the yarn, the fabric, and the pieces good.

Painting is the practice of applying pigment, suspended in a carrier (medium) and a binding agent (glue), to a surface (support) such as paper, fabric canvas or a wall. Painting can also be defined as a creation of art, with aesthetic value, made through the application of paint to a surface.

Earlier the printing technique was broadly classified, as machine classification comprised of flatbed printing and roller printing and process, including direct style printing and discharge style printing. This simple classification focused on the devices use in printing, i.e., flat screen and roller to carryout either direct or discharge printings The Grey fabric, directly taken from the loom undergoes several finishes to improve its luster, softness, drape, hand feel and ultimately its appearance. Dying adds colour to the fabric, an important contribution to fabric decoration .further, the fabric can be made attractive by printing colour and pattern on the finished fabric.

10.2 DIFFERENT STYLE OF PRINTING

There are three basic style of printing: direct, discharge and resist.

10.2.1. Direct style printing:

The most common and direct approach to apply colour pattern on the fabric is directly printing. It may be done on white or already dyed background, where in the letter often termed as over printing the dye is impregnated on the fabric in the paste form and the printing paste prepared by dissolving known quantity of dye in limited amount of water, to which a thickening agent is to provide necessary viscosity to the paste. Corn-starch was popularly used in cotton printing earlier. to the gums, glues, alginates and resins, which was preferred because of their favourable feature like low cost , odourless, suitable viscosity level, user friendly and easy to wash off . Most pigment is done without thickeners as such; the consistency is obtained by mixing resins, solvent and water required in proportion.

10. 2. 2. Discharge style printing:

It is another approach of applying colour on fabric. The technique is almost reverse to the resist printing. In simple words, it may be explained as reducing or destroying the colour in designed area of the piece dyed fabric. Sometimes the ground colour is removed and another colour is printed in its place. But often a white or light pattern is desirable to enhance the bright and dark ground colour.

10.2.3. Resist style printing:

In resist style of printing, a substance impermeable of dye or water is coated on the fabric in prescribed area thus prevents the absorption and penetration of the dye. The resisting agent completely envelops the air pores in the fabric, thus making it non-porous .Resisting agent may be natural or synthetic by origin and some examples are starch, clay, wax, resins, glue, gum, gelatine and synthetic or chemical agents. The technique of resist style of printing is well known in Persia, India, South America, and Egyptian fast east. The application of resist reagent is done through a device like block, but the application of the colour is done by dying only.

10.3 CHECK YOUR PROGRESS I

1. Write a definition of printing.

Spray printing is similar to that of stencil printing, where the colour instead of painting brushes, and tooth brush of fine or coarse type. The effect of spray printing would be mild, delicate, dotted or spotted, most suitable on delicate bed linen and table linen . It is not only an economic method of printing but also quick and labour saving technique.

10.4.2. Screen printing:



(fig.2.screen printing)

Screen printing earlier was known as a silkscreen printing, as the screen was made from fine yet durable silk filament. But today ,they are also made of nylon, polyester, vinyon and metal. The screens may be either flat or cylindrical and referred as flat screen printing and rotary screen printing, respectively.

1. Flat screen printing:

Flat screen printing was done by hand and now prepared mechanically. The design is copied or transferred on to a series of very fine flat screen, one screens for each colour to be printed. More often today the design is photographed and the negative is used for sensitized screen to opaque or block out, those areas not a part of the colour to be printed. Each ready screen is then separately fitted on to a wooden or metal frame.

2. Rotary screen printing:

Rotary screen printing is a continuous printing process. A perforated cylinder or spherical screen are used which are automatically fed with paste from inside by special pump. Each screen is independently driven.

10.4.3 Block printing:



(fig.3.block printing)

It appears to be the most ancient techniques of printing paper on the fabric by using wooden block, popular in India and prevails in many part of the world even today. From the historical records it is evident that man before 2000 BC knew printing fabrics. Block used for printing textiles was recovered from Egyptian graves of the fourth century A.D. The design is traced on that flat surface of the block and the background is engraved to raise the design , when dipped in printing paste, the design carries the colour and is stamped on the fabric is predetermined area. It is possible to print a design of 4-6 colours. a separate block for each other . Since block printing is entirely a manual process found to be slow, elaborate and labour intensive. Fine intricate designs are printed with blocks, having affixed fine metallic wire along the design instead engraving .blocks are also used in resist printing where the resisting agent was block printed and followed by dyeing the entire cloth. Block printing is also called copper plate printing when a copper plate with pattern inscribed mounted on the block. The inscription has the colour and is applied on the cloth by applying pressure manually.

● METHOD OF MACHINE PRINTING IN PRINTING

10.5.1 Roller printing:



(fig.4.roller printing)

Similar to rotary screen printing, roller printing evolves series of rollers each imprinting a different colour on the fabric. It is possible to print a design up to sixteen colours. The diameter of roller designate one repeat of design. whose speed range from 100 to 150 meter per minute. The rollers are made of copper with chromium plating of durability. tric that absorb s excess dye if any, thus prevents dye deposition on the drum. The design roller rotates, against a moving rotary brush that furnishes colour from the

roller and the doctor blade scrapes of another dye from the roller. The first roller imprints the design and the second roller adds second colour and so on the process continues till the design is completely printed. Roller must be aligned properly, failing which the colour may not fall in quite the correct position , resulting in to distortion. The fabric is then passed through steam chamber for dye fixation.

10.5 CHECK YOUR PROGRESS II

3. Write a short note on stencil printing.

4. Write a short note on block printing.

10.6 MULTIPLE CHOICE QUESTIONS

1. The same design is repeated many times across the fabric by pressing this decorated coloured surface against the fabric, which is nothing but _____.
(A) Art (B) Carving
(C) Labelling (D) Printing
2. _____ is a style of printing.
(A) Discharge (B) Clay
(C) Wood (D) Paint
3. Which printing machine's speed range are 100 to 150 per minute.
(A) Roller (B) Block
(C) Stencil (D) Screen
4. Screen printing earlier was known as a _____ printing
(A) Fabric (B) Silkscreen
(C) Mud (D) Batik
5. _____ is applied on the cloth by applying pressure manually.

- | | |
|------------|-----------|
| (A) Colour | (B) Paint |
| (C) Block | (D) Dyes |

10.7 LET US SUM UP

In this unit, we learnt definitions of printing and different printing methods, the Style of printing along with the materials and tools needed for this purpose. Some comments have also been made on the selection of fabric and tools and method of printing.

10.8 KEYWORDS

1. PIGMENT = a substance that gives colour to things.
2. SUBSTANCES= a solid or liquid material.
3. UNDERGOES= to have a difficult and unpleasant experience.
4. IMPREGNATED= soak or something with substance
5. ALGINATES = a salt or aligned acid.
6. RESIN = a sticky substances that is produced by some tree.
7. SOLVENT = a liquid that can dissolve another substances.
8. IMPREMEABLE = not allowing a liquid or gas to pass through.
9. PENTRATION = a movement into or through something.
10. AESTHETIC = concerned with beauty or art.
11. NOVELTY = the quality of being new and different.
12. PREVAILS = to exits or be common at particular place or particular time.
13. PREDETERMINDED = established or decided in advance time.
14. ELABORATE = very complicated, done or made very carefully.
15. CHROMIUM = a chemical element of atomic number 24, a hard white metal used in
Stainless-steel and other alloys.
16. DISTORSION = to change the shape of something so that it is false or wrong.

10.9 .SUGGESTED BOOKS

1. The Complete Guide Of Designing And Printing By Lurie Wisburn.
 2. Mastering The Art Of Fabric Printing And Design By Lurie Wisburn.
 3. Designing And Printing Textiles By June Fish 2005.
 4. Fabric Surface Design And Book By Cheryl Rezendes.
- { Note: Figures Are Adapted From Suggested Book List And Source Of Non-Copyrighted Materials }

10.10. ANSWER

1. Write a definition of printing.

The application of a pattern on to fabric by the use of dyes, pigments, or other colourer substances was influenced by a variety of hand and machine process. Here the design is transferred on a flat subtract, using a device coated with the dye, by simply stamping on the fabric. The same design is repeated many a times across the fabric by pressing this decorated coloured surface against the fabric, which is nothing but printing.

2. Write any 2 style of printing.

1. Direct style printing:

The most common and direct approach to apply colour pattern on the fabric is directly printing. It may be done on white or already dyed background, where in the latter often termed as over printing the dye is impregnated on the fabric in the paste form and the printing paste prepared by dissolving known quantity of dye in limited amount of water, to which a thickening agent is to provide necessary viscosity to the paste. Corn-starch was popularly used in cotton printing earlier, to the gums, glues, alginates, resins, which was preferred because of their favourable feature like low cost, odourless, suitable viscosity level, user friendly and easy to wash off. Most pigment is done without thickeners as such; the consistency is obtained by mixing resins, solvent and water required in proportion.

2. Discharge style printing:

It is another approach of applying colour on fabric. The technique is almost reverse to the resist printing. In simple words, it may be explained as reducing or destroying the colour in designed area of the piece dyed fabric. Sometimes the ground colour is removed and another colour is printed in its place. But often a white or light pattern is desirable to enhance the bright and dark ground colour.

3. Write a short note about stencil printing.

Stencil printing:

Stencil printing first started in china and japan. As the name suggest, stencils are necessary, which act, as template with design cut out, may be of cardboard, wood, metal, plastic or sturdy film. The design may be fine and delicate with large spaces through which a great amount of colour can be applied. Sometimes elaborate and complicated pattern may be developed using many stencils, one for each colour, the stencil printing however, usually limited to single colour or couple of colour and is generally applied on narrow widths of fabrics. Stencil printing is the basis for the method screen printing of today.

Spray printing is similar to that of stencil printing, where the colour instead of painting brushes, and tooth brush of fine or coarse type. The effect of spray printing would be mild, delicate, dotted or spotted, most suitable on delicate bed linen and table linen. it is not only an economic method of printing but also quick and labour saving technique.

4. Write a short note about block printing.

Block printing:

It appears to be the most ancient techniques of printing paper on the fabric by using wooden block, popular in India and prevails in many part of the world even today. From the historical records it is evident that man before 2000 BC knew printing fabrics. Block used for printing textiles was recovered from Egyptian graves of the fourth century A.D. The design is traced on that flat surface of the block and the background is engraved to raise the design, when dipped in printing paste, the design carries the colour and is stamped on the fabric in predetermined area. It is possible to print a design of 4-6 colours. a separate block for each other. Since block printing is entirely a manual process found to be slow, elaborate and labour intensive. Fine intricate designs are printed with blocks, having affixed fine

metallic wire along the design instead engraving .blocks are also used in resist printing where the resisting agent was block printed and followed by dying the entire cloth. Block printing is also called copper plate printing when a copper plate with pattern inscribed mounted on the block. The inscription has the colour and is applied on the cloth by applying pressure manually.

MCQ ANSWER

- 1. Printing**
- 2. Discharge**
- 3. Roller**
- 4. Silkscreen**
- 5. Block**

UNIT: 11

RIBBON WORK

11.0 OBJECTIVES

11.1 INTRODUCTION

11.2 TOOLS AND MATERIALS

11.3 CHECK YOUR PROGRESS I

11.4. METHOD

11.5 CHECK YOUR PROGRESS II

11.6 MULTIPLE CHOICE QUESTIONS

11.7 LET US SUM UP

11.8 KEYWORDS

11.9. SUGGESTED BOOKS

11.10. ANSWER

11.0 OBJECTIVES

- To understanding Ribbon work
- To learn Method of Ribbon work
- To gain knowledge about types of ribbon work

11.1 INTRODUCTION

Ribbon embroidery is a type of embroidery that is self-explanatory. At its most basic level, it is stitching with ribbon. However, this form of embroidery is much more than that, especially when used to create stunning dimensional pieces.

Dating back to the 1700s, silk ribbon embroidery shows up on embellished clothing, home decor items, quilts and more. It has gone through various periods of popularity and continues to be a favourite of many embroiderers today.

One of the things that stand out about ribbon embroidery is the texture it creates. Rather than simple stitches on the surface of the fabric, the bulk of the ribbon results in embroideries that seem to jump off of the material.

Flowers are a very common design to work with silk ribbon embroidery, most likely because the ribbon allows you to stitch very lifelike floral. Often a single stitch with ribbon will look like a flower bud, and the addition of one or two more stitches give you a bud with some greenery that reminds you of the real deal.

11.2 TOOLS AND MATERIALS

Ribbons



(fig.1. ribbon)

It's best to work ribbon embroidery with silk ribbons designed specifically for this type of work. It is possible to embroider with synthetic ribbons, but it can be more difficult. Silk is very thin, which makes it easier to pass through the fabric and sometimes, as needed, itself. It is also washable, which is a good feature when you are making something that you might wear. If you decide to work with a synthetic ribbon, test it with your fabric first to see how well it works its way through. These silk ribbons come in a variety of widths and it's helpful to have several available to work with. The different sizes make a huge difference when it comes to the look of your stitches, and as expected, the wider the ribbon, the bigger the impact.

Needles



(fig.2.needle)

When choosing a needle for your ribbon embroidery, it is important to have a sharp point and a large eye. Chenille needles in sizes 18-22 work well.

Fabric



(fig.3.fabric)

Pretty much any fabric that you can get a needle and the ribbon through will work for this embroidery; however, most stitches recommend working with natural fibres. If you are working with synthetic ribbon, you may want to use a fabric with a more open weave. As you are stitching, if you have trouble pulling the needle through, use a larger needle to make the holes before each stitch or switch to a looser fabric.

11.3 CHECK YOUR PROGRESS I

1. What is a ribbon work?

2. Tools and materials for ribbon work.

11.4. METHOD

- **Threading the Needle:-**

Threading your needle for silk ribbon embroidery is a little different than with other types of embroidery, and getting it started is important.

First, you should only work with short pieces of ribbon to avoid wear on the ribbon. About 12 inches is a good length, though you can go a little longer.

Thread one end of the ribbon through the eye of the needle, and then pierce the end of the ribbon with the needle. Pull the working ribbon down so that the short end draws near to the eye, locking the ribbon in place.

- **Starting and Stopping:-**

Because the back of this type of stitching can get bulky from the stitching itself, it is okay to start with a knot.

If you avoid that, you can leave a small temporary tail on the back of the fabric, holding it in place as you make the first stitches. After a few stitches in place, use a single strand of embroidery floss in a colour that matches your ribbon and tack the tail to the back of a stitch or two of ribbon. Take care that the stitches don't show on the front.

Likewise, when ending you can finish with a knot and slide the tail of the ribbon under a stitch or two, then trim off the remaining ribbon and needle or, follow a similar method as above, stitching the tail in place.

- **Stitches:-**

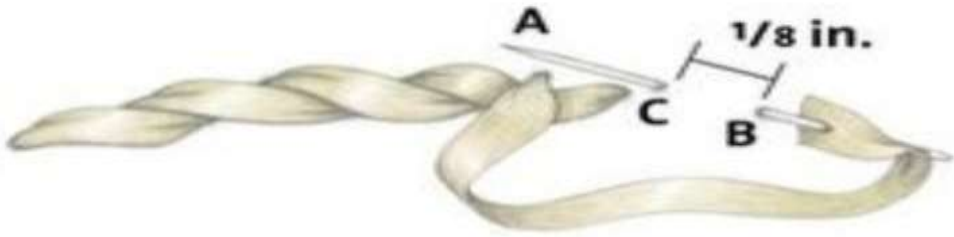

(fig 4.stitches)

Ribbon stitch is the most common stitch in ribbon embroidery. This stitch helps form different flowers and other motifs, and while it can take some practice, it's one to learn.

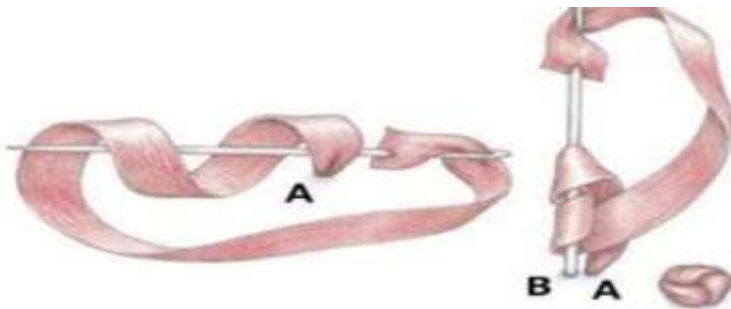

(fig.5. stitches)

Apart from ribbon stitch, if you have done any surface embroidery, you most likely already know the other stitches that show up in silk ribbon embroidery. And you'll love seeing how the same stitch can look so different when worked in different sizes of ribbon.

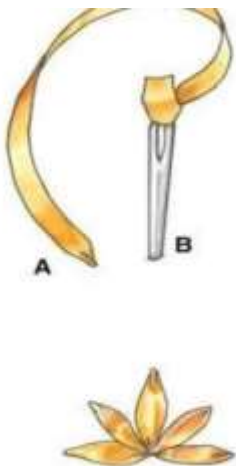

(fig.6.flower)

2. _____ is very common design to work with silk ribbon embroidery.
- (A) Square (B) flower
(C) Abstract (D) human figure
3. Ribbon embroidery needle should be _____ point and _____ eye.
- (A) Small, small (B) large, small
(C) Sharp, large (D) large, sharp
4. Ribbon embroidery is to create stunning _____ piece.
- (A) Dimensional (B) base
(C) Colourful (D) four dimensional
5. It is the best to work ribbon embroidery with _____ ribbon.
- (A) Cotton (B) poplin
(C) Wool (D) silk

11.7 LET US SUM UP

In this unit, we learnt about Ribbon work, and its use which are provided with some sequential steps, the materials and equipment required for ribbon work are also listed in this unit. We also learnt different methods and stitches of ribbon work as part of this unit.

11.8 KEYWORDS

1. EXPLANATORY: explaining, describing, illustrative, evaluative
2. DIMENSIONAL: relating to measurement or dimensions
3. IMPACT: the action of one object coming forcibly into contact with another.
4. BULKY: large, big, great, and huge
5. TAIL: back end, appendage
6. RIBBON: a long , narrow strips of fabric, used for tying something or for decoration
7. EXCLUSIVE: whole, total, complete, full, entire
8. MOTIF: design, pattern, shape, logo, figure
9. TRIM: cut, crop, clip, shear, and shorten

11.9. SUGGESTED BOOKS

1. Ribbon Work The Complete Guide-Helen Gibb
 2. Elegant Ribbon Work- Helen Gibb
 3. Artful Ribbon – Candace Klieg
- { Note: Figures Are Adapted From Suggested Book List And Source Of Non-Copyrighted Materials }

11.10. ANSWER

1. What is a ribbon work?

Ribbon embroidery is a type of embroidery that is self-explanatory. At its most basic level, it is stitching with ribbon. However, this form of embroidery is so much more than that, especially when used to create stunning dimensional pieces.

2. Tools and materials for ribbon work.

Ribbons

It's best to work ribbon embroidery with silk ribbons designed specifically for this type of work. It is possible to embroider with synthetic ribbons, but it can be more difficult. Silk is very thin, which makes it easier to pass through the fabric and sometimes, as needed, itself. It is also washable, which is a good feature when you are making something that you might wear. If you decide to work with a synthetic ribbon, test it with your fabric first to see how well it works its way through. These silk ribbons come in a variety of widths and it's helpful to have several available to work with. The different sizes make a huge difference when it comes to the look of your stitches, and as expected, the wider the ribbon, the bigger the impact.

When choosing a needle for your ribbon embroidery, it's most important to have a sharp point and a large eye. Chenille needles in sizes 18-22 work well.

Pretty much any fabric that you can get a needle and the ribbon through will work for this embroidery; however, most stitches recommend working with natural fibres. If you are working with synthetic ribbon, you may want to use a fabric with a more open weave. As you are stitching, if you have trouble pulling the needle through, use a larger needle to make the holes before each stitch or switch to a looser fabric.

3. Method of ribbon work.

● = Threading the Needle:-

Threading your needle for silk ribbon embroidery is a little different than with other types of embroidery, and getting it started is important.

First, you should only work with short pieces of ribbon to avoid wear on the ribbon. About 12 inches is a good length, though you can go a little longer.

Thread one end of the ribbon through the eye of the needle, then pierce the end of the ribbon with the needle. Pull the working ribbon down so that the short end draws near to the eye, locking the ribbon in place.

● Starting and Stopping:-

Because the back of this type of stitching can get bulky from the stitching itself, it is okay to start with a knot.

If you avoid that, you can leave a small temporary tail on the back of the fabric, holding it in place as you make the first stitches. After a few stitches in place, use a single strand of embroidery floss in a colour that matches your ribbon and tack the tail to the back of a stitch or two of ribbon. Take care that the stitches don't show on the front.

Likewise, when ending you can finish with a knot and slide the tail of the ribbon under a stitch or two, then trim off the remaining ribbon and needle or, follow a similar method as above, stitching the tail in place.

● **Stitches:-**

Ribbon stitch is the most common stitch in ribbon embroidery. This stitch helps form different flowers and other motifs, and while it can take some practice, it's one to learn.

Apart from ribbon stitch, if you have done any surface embroidery, you most likely already know the other stitches that show up in silk ribbon embroidery. And you'll love seeing how the same stitch can look so different when worked in different sizes of ribbon.

4. What is ribbon as a tool?

Ribbons

It's best to work ribbon embroidery with silk ribbons designed specifically for this type of work. It is possible to embroider with synthetic ribbons, but it can be more difficult. Silk is very thin, which makes it easier to pass through the fabric and sometimes, as needed, itself. It is also washable, which is a good feature when you are making something that you might wear. If you decide to work with a synthetic ribbon, test it with your fabric first to see how well it works its way through. These silk ribbons come in a variety of widths and it's helpful to have several available to work with. The different sizes make a huge difference when it comes to the look of your stitches, and as expected, the wider the ribbon, the bigger the impact.

MCQ ANSWER

- 1. Ribbon**
- 2. Flower**
- 3. Sharp, Large**
- 4. Dimensional**
- 5. Silk**

UNIT: 12

BEADS AND SEQUINS WORK

12.0 OBJECTIVES**12.1 INTRODUCTION****12.2 TOOLS AND MATERIALS****12.3 CHECK YOUR PROGRESS I****12.4. METHOD****12.5 CHECK YOUR PROGRESS II****12.6 MULTIPLE CHOICE QUESTIONS****12.7 LET US SUM UP****12.8 KEYWORDS****12.9. SUGGESTED BOOKS****12.10. ANSWER**

12.0 OBJECTIVES

- To gain knowledge about beads and sequins.
- To learn method of beads work.
- To learn method of sequins work.

12.1 INTRODUCTION

BEADS

Bead is a small round piece of wood, glass or plastic with a hole in the middle for putting a string through to make design.

The history of beads work is several hundred years old. The first evidence of bead work was found in Egyptian culture. There are several types of beads found in the world (gold, jade, bone, turquoise stone, and polished shell beads).

SEQUINS

A small shiny round piece of metal or plastic that are sewn on clothing to as decoration.

By making use of sequins work, one can craft fine embroidery on sarees, lehngas and Salwar kameez. Sequins work is extensively used by designers for making bridal costumes. Sequins work can also be done by machine.

12.2 TOOLS AND MATERIALS

- **Round Wooden Frame:** It is used to fix the plain cloth for stiffness.



(fig.1.wooden frame)

- **Needle:** It is used to sharp hook shaped needle used to embroider the fabric.
- **Silk Thread** is required for a basic bead and sequin work.



(fig.2. silk thread)

- **Fabric:** Cotton velvet cloth is used to embroider the required design.
- **Sequin Beads:** It is used to enhance the design.



(fig.3.sequin)

- **Tailor's Chalk:** It is used to draw designs on framed fabric.



(fig.4.tailors chalk)

12.3 CHECK YOUR PROGRESS I

1. What are beads & sequins?

2. Write a list of tools and materials necessary for beads & sequins work.

12.4. METHOD

. PROCESS OF MAKING:

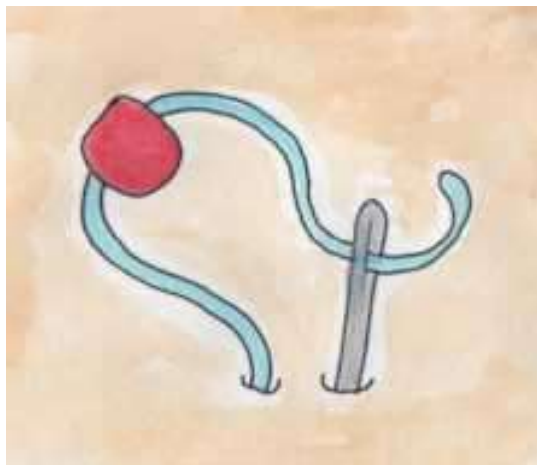

(fig.5. method of beads work)

- At the outset, trace the design on the desired fabric.
- Make a string of beads first. Align the bead chain along the outline of the motif.
- Start making satin stitch along the beads. It locks the beads in the fabric along the trace.
- After every bead give a bar tack to lock them onto the fabric.
- Bar tack gives the beads stability.
- Remember beads strings cannot be used to fill the motif; it is just required to outline the motif.

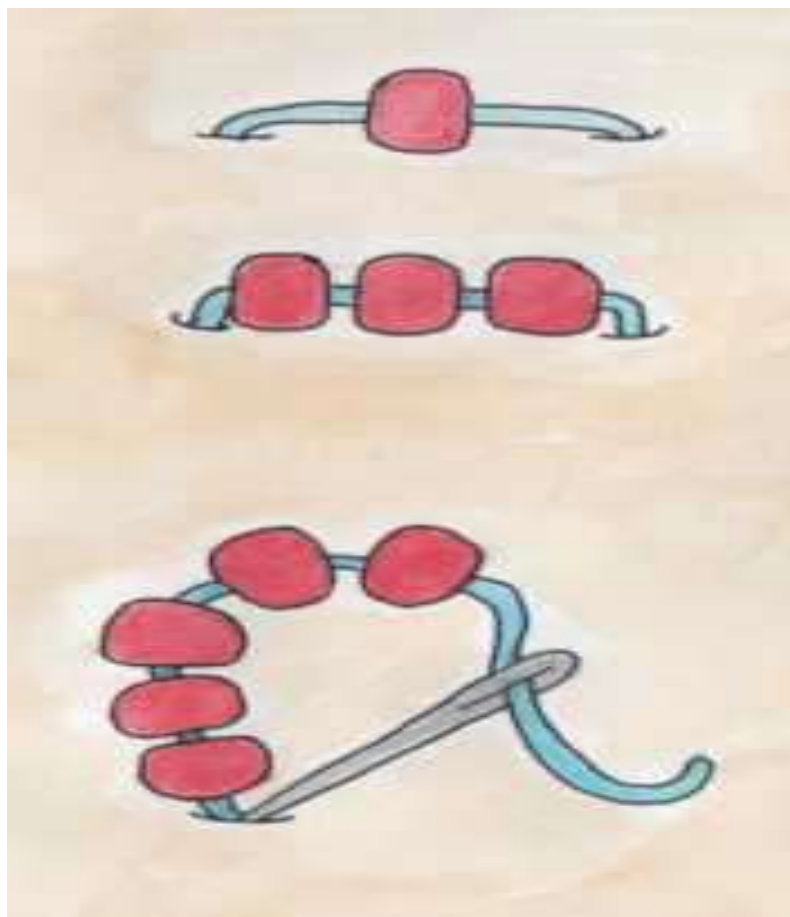

(fig.6. method of bead work)

Sewing on a bead

1. Bring your needle up from the back of the fabric through the hole in the bead.
2. Bring your needle down through the fabric; your stitch should be the same width as the bead.

Variations

1. Make your stitch longer than the bead so that it is visible and the bead can move along the completed stitch.
2. Sew a number of beads with the same stitch.
3. Thread five or six or more beads onto the thread and then take it down through the fabric at the same point that you started to Form a loop of beads.

SEQUINS: PROCESS OF MAKING:

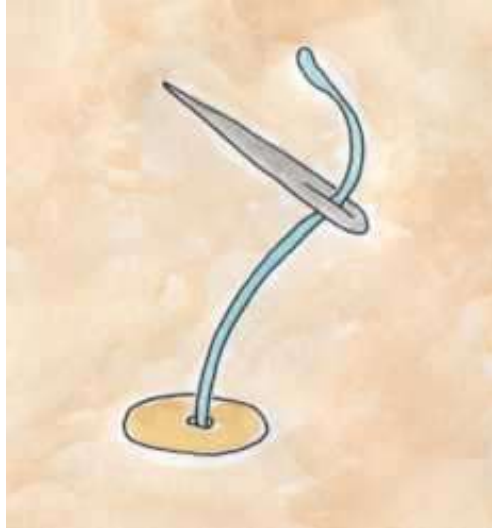

(fig.7.sequin process)

- First trace the design on the desired fabric.
- Sequins are available in two types in the market; flat and Katori. The flat sequins are easy to attach than the Katori sequins.
- To start, place the sequin on the outline of the design. Put the threaded needle inside the hole of sequins and pull the needle out so that it forms a loop at the lower end.
- Once the needle comes out through the same hole of the first sequin, place another sequin beneath the first one such that the next drop of the needle falls into the hole of the second sequin. The overlapping of the sequin depends on the stitch length.
- Repeat the process till the whole motif is completed.
- With Katori sequins first put all the sequins in a thread like a string. Do not tie knots on the string ends. A string is required because the sequins are not flat in this case. Due to its 3- D structure it is easier to handle them by aligning them in a string.
- Put this string onto the motif. Keep running the machine like before by drawing the sequins in the string close to each other. Later when the motif gets completed and the sequins are attached on the fabric pull the string out carefully.
- Avoid using metal sequins as that would lead to needle breakage.

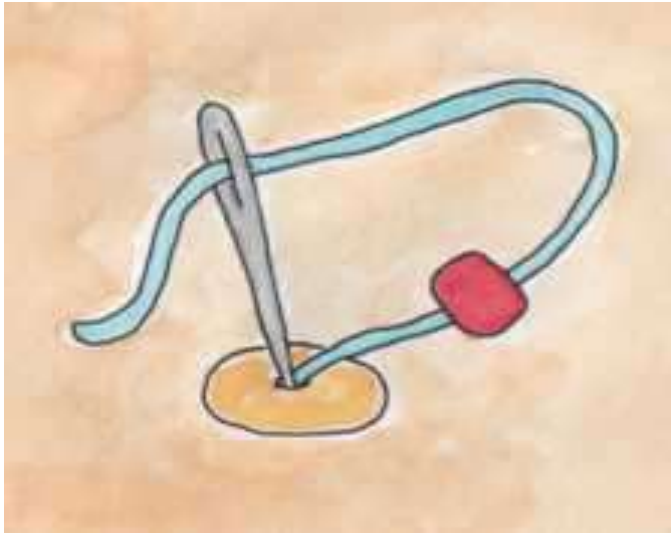

(fig.8. sequin and bead)

Sewing on a sequin

1. Bring your needle up from the back of the fabric through the hole in the sequin.
2. Bring your needle down through the fabric at the edge of the sequin.
3. Bring your needle up through the hole in the sequin.
4. Bring your needle down through the fabric at the edge of the sequin opposite the first holding stitch.

Variations

1. Make a cross with the holding stitches
2. Make a star with the holding stitches
3. Vary the length of the holding stitches – they can extend beyond the edge of the sequin



(fig. 9. method of sequin)

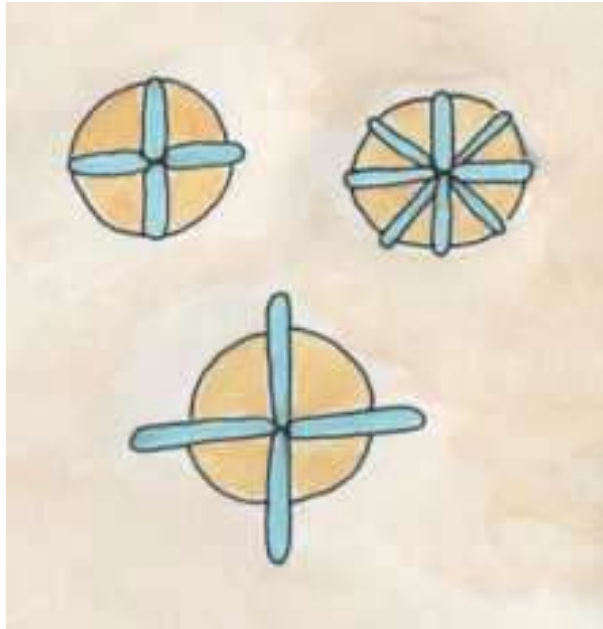

(fig.10.method of sequin)

Attaching a sequin with a bead

1. Bring your needle up from the back of the fabric through the hole in the sequin.
2. Thread a bead onto the needle.
3. Take your needle down through the hole in the Sequin.

SEQUIN BY MACHINE

Sequin embroidery machine embroider on garments and this machine is made by multi head and multi needle, that can embroider several free embroidery design at the same time it can realize the function of auto trimmer. The feature of sequin machine is automatic control of embroidery, no need hand embroidery, make the embroidery robotization. This sequin embroidery can change the color according the embroidery design when in embroider. Some machine may assembly double sequin in first needle or last needle, the movement of sequin machine can be driven by motor or valve. This sequin machine support sequin machine support sequin embroidery stitch with all kinds of lock-stitch and chain stitch. Sequin embroidery machine makes secret of free embroidery design that gives us beautiful embroidery

FUNCTION OF SEQUIN EMBROIDERY MACHINE WHICH EMBROIDER ON GARMENTS:

- Multi heads and multi needles sequin machin can embroider some chain stitch designs at the same,
- Thread breakage head position when the thread break during embroider,
- Sequin machine can repair embroider and make embroidery stitch,
- Attaching the sequin device it can embroidery sequin design and combine flat embroider at a time,
- Making beautiful free embroidery designs by embroidery digitizing process.,
- Attaching the cording it can embroider the cording design and combine flat embroider the boring designs also,

- It looks like hand embroidery ,
- Some machine provide free embroidery designs,

12.5 CHECK YOUR PROGRESS II

3. Write a method of bead work.

4. Write a method of sequins work.

12.6 MULTIPLE CHOICE QUESTIONS

- _____ is a small round piece of wood, glass or plastic with a hole in the middle for putting a string through to make design.
 (A) Bead (B) Bricks
 (C) Button (D) Ball
- _____ is a small shiny round piece of metal or plastic that sewn on clothing to as decoration.
 (A) Stone (B) Sequin
 (C) Scale (D) Stencil
- Sequins are available in two types in the market; flat and _____.
 (A) Thick (B) Bead
 (C) Glass (D) Katori
- Sequins work can also be done by _____.
 (A) Stencil (B) Painting
 (C) Machine (D) Hand
- _____ is a basic thread of beads & sequins work.
 (A) Velvet (B) Silk
 (C) Jute (D) Nylon

12.7 LET US SUM UP

In this unit, we learnt Beads and Sequins work. Making beads & sequins have been listed along with the materials and tools needed for this purpose. Some comments have also been offered on the selection of Fabric and the threads used.. Many patterns can be created using the combination of sequins on saree, dress materials, party wear etc.

12.8 KEYWORDS

1. EVIDENCE: the fact, sign that make you believe that something is true.
2. ENHANCE: to improve something or make something look better.
3. OUTSET: the start or beginning of something.
4. STRING: a piece of long strong material like very thin rope that you use for tying things.

12.9. SUGGESTED BOOKS

1. Beads And Sequin Embroidery Stitches By Stanley Levy
 2. Embroidered And Emblished By Christen Brown
 3. Bead Embroidery By Yukiko Agura
- { Note: Figures Are Adapted From Suggested Book List And Source Of Non-Copyrighted Materials }

12.10. ANSWER

1. What are a beads & sequins?

BEADS

Bead is a small round piece of wood, glass or plastic with a hole in the middle for putting a string through to make design.

The history of beads work is several hundred years old. The first evidence of bead work was found in Egyptian culture. There are several types of beads found in the world (gold, jade, bone, turquoise stone, and polished shell beads).

SEQUINS

A small shiny round piece of metal or plastic that are sewn on clothing to as decoration.

By making use of sequins work, one can craft fine embroidery on sarees, lehngas and Salwar kameez. Sequins work is extensively used by designers for making bridal costumes. Sequins work can also be done by machine.

2. Write a list of tools and materials for beads & sequins work.

- Round Wooden Frame: It is used to fix the plain cloth for stiffness.
- Needle: It is used to sharp hook shaped needle used to embroider the fabric.
- Silk Thread: It is a basic beads & sequins work.
- Fabric: Cotton velvet cloth is used to embroider the required design.
- Sequin Beads: It is used to enhance the design.
- Tailor's Chalk: It is used to draw designs on framed fabric.

3. Write a method of bead work.

. PROCESS OF MAKING:

- At the outset, trace the design on the desired fabric.

- Make a string of beads first. Align the bead chain along the outline of the motif.
- Start making satin stitch along the beads. It locks the beads in the fabric along the trace.
- After every bead give a bar tack to lock them onto the fabric.
- Bar tack gives the beads stability.
- Remember beads strings cannot be used to fill the motif; it is just required to outline the motif.

Sewing on a bead

1. Bring your needle up from the back of the fabric through The hole in the bead.
2. Bring your needle down through the fabric, your stitch Should be the same width as the bead.

4. Write a method of sequins work.

- First trace the design on the desired fabric.
- Sequins are available in two types in the market; flat and Katori. The flat sequins are easy to attach than the Katori sequins.
- To start, place the sequin on the outline of the design. Put the threaded needle inside the hole of sequins and pull the needle out so that it forms a loop at the lower end.
- Once the needle comes out through the same hole of the first sequin, place another sequin beneath the first one such that the next drop of the needle falls into the hole of the second sequin. The overlapping of the sequin depends on the stitch length.
- Repeat the process till the whole motif is completed.
- With Katori sequins first put all the sequins in a thread like a string. Do not tie knots on the string ends. A string is required because the sequins are not flat in this case. Due to its 3- D structure it is easier to handle them by aligning them in a string.
- Put this string onto the motif. Keep running the machine like before by drawing the sequins in the string close to each other. Later when the motif gets completed and the sequins are attached on the fabric pull the string out carefully.
- Avoid using metal sequins as that would lead to needle breakage.

Sewing on a sequin

1. Bring your needle up from the back of the fabric through the hole in the sequin.
2. Bring your needle down through the fabric at the edge of the sequin.
3. Bring your needle up through the hole in the sequin.
4. Bring your needle down through the fabric at the edge of the sequin opposite the first holding stitch.

MCQ ANSWER

- 1. Bead**
- 2. Sequin**
- 3. Katori**
- 4. Machine**
- 5. Silk**

UNIT: 13

AARI AND ZARDOZI WORK

13.0 OBJECTIVES**13.1 INTRODUCTION****13.2 TOOLS AND MATERIALS****13.3 CHECK YOUR PROGRESS I****13.4. METHOD****13.5 CHECK YOUR PROGRESS II****13.6 MULTIPLE CHOICE QUESTIONS****13.7 LET US SUM UP****13.8 KEYWORDS****13.9 SUGGESTED BOOKS****13.10. ANSWER**

13.0 OBJECTIVES

- To gain knowledge about Aari and Zardozi
- To gain knowledge about tools & materials of Aari and Zardozi
- Learn techniques and method of Aari and Zardozi

13.1 INTRODUCTION



(fig.1.Aari)

Aari work is a delicate form of hand embroidery which requires great efficiency and skills. For the stitches of aari work, the embroiderer needs

the usage of both his/her hands; hence, instead of using the normal embroidery hoop, frames are used. Frame is a wooden adjustable frame with four wooden bars used to stretch the fabric for embroidery. The fabric is attached to the frames mainly for doing aari work. Aari is a type of needle with a hook at its tip to do the embroidery while working on frames. Because of its name Aari, the embroidery done by it is called Aari work. Frame and Aari help in working speedily, and with precision and neatness. Before starting this embroidery, one has to do some basic preparations, like preparation of the frame and attaching the fabric which is to be embroidered on it. Then, the design selected is transferred onto the fabric, using proper tracing methods used to transfer the designs onto the fabric in Aari work.

Zardozi or zari work



(fig.2.zardozi)

It is the embroidery work in metal wires. Metal ingots are melted and compressed through perforated steel sheets to convert them into wires in this work. They are then hammered to the required thickness. Plain flat wire is called badla; whereas the rounded is called aari work involves a needle with a hook, which is fed by cotton, zari or silk thread from below with the material tucked out on a frame. This movement creates loops of chain stitch, and repeats of these leads to a line of chain stitches. From the underside of the Fabric, the other hand feeds the thread, and the hook brings it up, making a chain stitch. It is much faster than the chain stitch done in the common way by hand on a frame. It looks very well finished, almost like machine made. This can also be ornamented with sequins and beads, which are kept on the right side, and the needle goes inside their holes before plunging below, thus securing them to the fabric. The cloth to be embroidered is first stitched to the thick cloth strap attached to the frame. Thereafter, with the help of needle, the embroidery is started. The

hook of the aari enables the embroiderer to pass the threads both above and below the fabric. This method of embroidery is very time consuming and therefore, the products are expensive. Depending on the intricacy and type of design, it may take a day or a month to complete a design. Zardozi embroidery requires patience and expertise.

It is one of the most common choices for bridal and designer wears like lehenga-chunni, giving the clothing a rich look. Aari work, these days, with the help of advanced stitching procedures, and the role of more artisans working together and proper planning, takes Lesser time to complete. The embroidery on frames is worked in two distinct styles. The first, zardozi work, is recognizable by the density of its stitches on heavy base materials, such as

Velvet or satin. It is usually seen on items, like sherwanis, suits, sarees, bags, purses, cushions, curtains, shoes and belts, jackets, coats, tent coverings, The other style is kamdani, which is a lighter and more delicate work. It adorns rich and elegant

Fabrics like muslin and silk. Although this kind of work is considered far more suitable for stoles and veils, yet in these days it is very common in bridal wear too.

13.2 TOOLS AND MATERIAL

1. Adda (wooden frame)

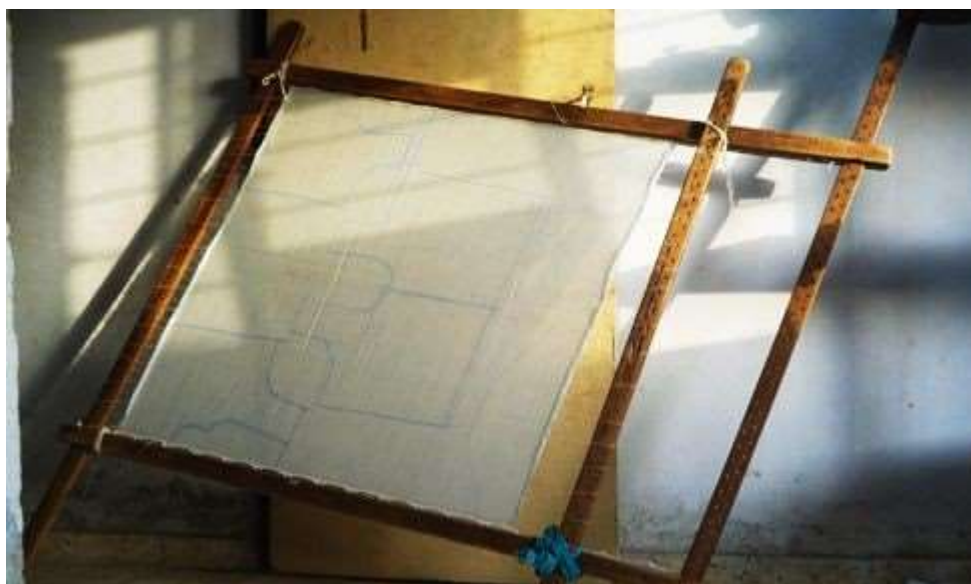

(fig.3.frame)

It is a horizontal wooden adjustable frame, consisting of four wooden bars. It is raised sufficiently from the ground to make it convenient for the embroiderer to work, without having to bend too far forward while sitting on the ground. The needle is always pushed in such a way that it should be away from the embroiderer and never towards him/her. The fabric on which the embroidery is to be done is first stitched on the two horizontal wooden bars and stretched apart. Then it is fixed tightly and locked onto the other two vertically

parallel wooden bars of the adda. This prevents the fabric from moving while working, and also enables clear vision and faster movement of the tools.

2. Aari (needle)



(fig.4.aari needle)

It is the main tool of the zardozi embroidery. It has a hook at the tip and a wooden handle at the back. The needles are also available with an iron and a plastic handle. Aari (needles) are available in different sizes and thickness, which may be selected according to the type of the Fabric. Design and raw material used. For fine fabric, fine aari is used, while for a heavy fabric, a thick aari is used. An aari may be selected according to the raw material also, for example aari for zari, aari for sitara or for dabka, etc. Thus, it can be selected by the embroiderer according to his/her requirement, looking into all the aspects of embroidery work. Aari resembles the shape of a crochet needle and is a pen-like needle. It forms an intrinsic form of artwork called the aari work.

The needle hooks are made of iron;

They are sometimes handcrafted;

They do not damage the fabrics, even very fine fabrics, as they are filled properly;

They look like crochet hooks but are still different from it; and

They are of different sizes according to the use. For example: hooks used to stitch

3. Scissors



(fig.5.scissors)

These should have slender blades from 1 ½” to 2 ½” long that taper to narrow, sharp points. These should be of very good quality steel so that keen cutting of edges and Threads are assured.

4. Needles



(fig.6.needle)

In adda work, embroidery needles are also used. The Most commonly used needle for embroidery is a crewel; Sometimes also known as an embroidery needle. Except for its long slender eye, it does not differ materially from the sewing needle in shape and it comes in the same Size and numbers. Crewels should be used unless some other kind of needle is specified.

5. Thimble



(fig.7.thimble)

It is a small plastic, metal or rubber cap for the finger Or thumb. Mostly it is close-ended. It is worn to protect the finger and/or thumb and push the needle while embroidering.

6. Gold and silver threads



(fig.8.thread)

Originally, embroidery was done by using pure gold and silver threads. These Threads were made by metal (gold and silver blocks). The craftsmen melted them in small workshops at their homes and pressed them through iron sheets having Perforations to make thin wires.

The size of the perforations varied as per the requirement of the threads. Simple Plain flat wire is called badla. Sometimes, the badla is wrapped around a thread and is called kasab. The twisted wire is called nakshi. These days, artificially made bright gold, dull gold, Bright silver, antique silver and copper colour threads are commonly used.

7. Metal wires



(fig.9.metal wires)

In recent times, gold and silver has been replaced by metal wire made of mainly copper and steel.

8. Dabka and Sitara

These are used as ornamentations in the zardozi embroidery. Dabka is a spring-like thread. It is cut into small sized pieces and used as per the requirement to make the shapes of flowers and leaves in a design. Sitara is golden or silver in colour, but even coloured ones in different shapes are available these days in the market.

9. Embroidery threads



(fig.10. embroidery threads)

The thread used for embroidering any design must be carefully chosen for colour, texture and size, because all these factors contribute to the final effect. Fine threads are usually employed on fine fabrics. Stranded threads, corded threads, highly-twisted lustrous threads, thick, matty, cotton thread and pure silk threads are mainly used in hand embroidery. They may also be used in Embroidery on adda depending upon the design and materials. before beginning embroidery work, ensure colour fastness of both the fabric as well as the thread used.

13.3 CHECK YOUR PROGRESS I

1. Write a definition of Aari work.

2. Write a definition of Zardozi.

13.4. METHOD

Setting of adda



(fig.11.working on frames)

The fabric which is to be embroidered is held onto the adda following an elaborate process, which requires great precision. The tightening of fabric is known as tangarna and involves more than one person. Adda is a wooden frame mainly used for aari work on which the fabric to be embroidered is stretched tightly, making it comfortable and suitable for working. This frame has adjustable wooden bars which are rested on four stools or stands at four corners. These frames can also be customised according to the width of the fabric. These frames are large and mainly made up of sheesham wood. It is strong, hard and durable, but sometimes bamboo is also used as an alternative material. One frame can provide accommodation to 4–6 artisans sitting on both of its sides. To sit in a comfortable manner, the height of the frame is usually 1.5–2 feet above the ground. The artisans, both male and female, sit either on the floor or on cushions. For smaller designs, small metal frames can be used instead of wooden planks. The adda or frame has four stands, two main bars and two sidebars. It is similar to the frames of a slate. The two main bars have evenly placed holes, through which a thick cotton rope is passed twice. A strip of cotton cloth is attached to one side (inner side) of the main bar. The embroiderer has to sit on the floor to embroider.

Attaching the fabric

1. The fabric is first joined to the two main bars.
2. The centres of the bar as well as of the fabric are marked on both sides and pinned up.
3. Cotton thread is used to sew the first side of the fabric to one of the cotton strips of the main bars.
4. To begin, a knot is made and to end, 4–5 back stitches are done onto the white cotton cloth, which is attached on the bars.
5. Then, the second side to the other bar is stitched and rolled.
6. Now, the stretcher bars are inserted and the frame is stretched to place the pegs or nails.
7. Then, the selvages are folded. Small darning stitches are sewn and the same thread passes through these stitches, then the fabric is pulled tightly. Now, the thread is pulled and tied to the peg or nail.
8. Now all the four sides of the fabric are stretched.



(fig.12.khakha process)

Khaka making process

In this process, a paper of design is pricked with a pin at regular intervals. The pattern is then pinned up to the fabric and a coloured chalk powder is spread through the holes in a pouncing motion using a soft fabric pad. Pouncing materials can be found in specialty needle workshops. The pattern pricked on the transparent sheet of paper, that is pinned to the fabric is called khaka.

13.5 CHECK YOUR PROGRESS II

3. Write a list of tools and materials necessary for aari & zardozi.

4. Write a process of setting adda and khaka work.

13.6 MULTIPLE CHOICE QUESTIONS

1. _____ work is a delicate form of hand embroidery which requires great efficiency and skills. For the stitches of aari work.
(D) Aari (B) Bead
(C) Sequin (D) Quilling
2. Zardozi is the _____ work in metal wires.
(A) Sew (B) Tie
(C) Embroidery (D) Batik
3. _____ is worn to protect the finger and/or thumb and push the needle while embroidering.
(A) Fabric (B) Thimble
(C) Eye saver (D) Stitch opener
4. _____ is a horizontal wooden adjustable frame, consisting of four wooden bars.
(A) Aari (B) Khaka
(C) Pin (D) Adda
5. _____ is the main tool of the zardozi embroidery
(A) Dabka (B) Sitara
(C) Aari (D) Adda

13.7 LET US SUM UP

In this unit, we learnt Aari and Zardozi work, after a brief introduction to the subject, and we also gained knowledge about aari work, zardozi work and we learnt about required tools and materials, the process of this work, and process for setting adda (frame) & khaka process.

13.8 KEYWORDS

1. EFFICIENCY: the good use of time & energy.
2. PRECISION: the quality of being clean or exact.
3. NEATNESS: the quality of being tidy, with everything in its place.
4. INGOTS: a solid piece or method.
5. INTRICACY: the complicated parts or details of something.
6. EXPERTISE: clear, easily seen, heard or understood.
7. DISTINET: a high level of special knowledge or skills.

13.9. SUGGESTED BOOKS

1. Embroidery Design By Nirmala Mistry
2. Indian Embroidery By Irwin & Hall

3. Complete Designing Of Textile Fabric By Shailaja D. Naik

{ Note: Figures Are Adapted From Suggested Book List And Source Of Non-Copyrighted Materials }

13.10. ANSWER

1. Write a definition of Aari and Zardozi.

Aari work is a delicate form of hand embroidery which requires great efficiency and skills. For the stitches of aari work, the embroiderer needs the usage of both his/her hands; hence, instead of using the normal embroidery hoop, frames are used. Frame is a wooden adjustable frame with four wooden bars, used to stretch the fabric for embroidery. The fabric is attached to the frames mainly for doing aari work. Aari is a type of needle with a hook at its tip to do the embroidery while working on frames. Because of its name aari, the embroidery done by it is called aari work. Frame and aari help in working speedily, and with precision and neatness. Before starting this embroidery, one has to do some basic preparations, like preparation of the frame and attaching the fabric which is to be embroidered on it. Then, the design selected is transferred onto the fabric, using proper tracing methods used to transfer the designs onto the fabric in aari work.

Zardozi is the embroidery work in metal wires. Metal ingots are melted and compressed through perforated steel sheets to convert them into wires in this work. They are then hammered to the required thickness. Plain flat wire is called badla; whereas the rounded is called aari work involves a needle with a hook, which is fed by cotton, zari or silk thread from below with the material tucked out on a frame. This movement creates loops of chain stitch, and repeats of these leads to a line of chain stitches. From the underside of the fabric, the other hand feeds the thread, and the hook brings it up, making a chain stitch. It is much faster than the chain stitch done in the common way by hand on a frame. It looks very well finished, almost like machine made. This can also be ornamented with sequins and beads, which are kept on the right side, and the needle goes inside their holes before plunging below, thus securing them to the fabric. The cloth to be embroidered is first stitched to the thick cloth strap attached to the frame. Thereafter, with the help of needle, the embroidery is started. The hook of the aari enables the embroiderer to pass the threads both above and below the fabric. This method of embroidery is very time consuming and therefore, the products are expensive. Depending on the intricacy and type of design, it may take a day or a month to complete a design. Zardozi embroidery requires patience and expertise.

3. Write a list of tools and materials for aari & zardozi.

1 Adda (wooden frame)

It is a horizontal wooden adjustable frame, consisting of four wooden bars. It is raised sufficiently from the ground to make it convenient for the embroiderer to work, without having to bend too far forward while sitting on the ground. The needle is always pushed in such a way that it should be away from the embroiderer and never towards him/her. The fabric on which the embroidery is to be done is first stitched

on the two horizontal wooden bars and stretched apart. Then it is fixed tightly and locked onto the other two vertically parallel wooden bars of the adda. This prevents the fabric from moving while working, and also enables clear vision and faster movement of the tools.

2 Aari (needle)

It is the main tool of the zardozi embroidery. It has a hook at the tip and a wooden handle at the back. The needles are also available with an iron and a plastic handle. Aari (needles) are available in different sizes and thickness, which may be selected according to the type of the Fabric. design, type of thread and raw material used. For fine fabric, fine aari is used, while for a heavy fabric, a thick aari is used. An aari may be selected according to the raw material also, for example aari for zari, aari for sitara or for dabka, etc. Thus, it can be selected by the embroiderer according to his/her requirement, looking into all the aspects of embroidery work. Aari resembles the shape of a crochet needle and is a pen-like needle. It forms an intrinsic form of artwork called the aari work.

The needle hooks are made of iron;

They are sometimes handcrafted;

They do not damage the fabrics, even very fine fabrics, as they are filled properly;

They look like crochet hooks but are still different from it; and

They are of different sizes according to the use. For example: hooks used to stitch .

3. Scissors

These should have slender blades from 1 ½” to 2 ½” long that taper to narrow, sharp points. These should be of very good quality steel so that keen cutting of edges and Threads are assured.

4. Needles

In adda work, embroidery needles are also used. The Most commonly used needle for embroidery is a crewel; Sometimes also known as an embroidery needle. Except For its long slender eye, it does not differ materially from The sewing needle in shape and it comes in the same Size and numbers. Crewels should be used unless some other kind of needle is specified.

5. Thimble

It is a small plastic, metal or rubber cap for the finger Or thumb. Mostly it is close-ended. It is worn to protect the finger and/or thumb and push the needle while embroidering.

6. Gold and silver threads

Originally, embroidery was done by using pure gold and silver threads. These Threads were made by metal (gold and silver blocks). The craftsmen melted them in small workshops at their homes and pressed them through iron sheets having Perforations to make thin wires.

The size of the perforations varied as per the requirement of the threads. Simple Plain flat wire is called badla. Sometimes, the badla is wrapped around a thread and is called kasab. The twisted wire is called nakshi.

These days, artificially made bright gold, dull gold, Bright silver, antique silver and copper colour threads are commonly used.

7. Metal wires

In recent times, gold and silver has been replaced by metal wire made Out of mainly copper and steel.

8. Dabka and sitara

These are used as ornamentations in the zardozi embroidery. Dabka is a spring-like thread. It is cut into Small sized pieces and used as per the requirement to make the shapes of flowers and leaves in a design. Sitara is golden or silver in colour, but even coloured ones in different shapes are available these days in the market.

9. Embroidery threads

The thread used for embroidering any design must be carefully chosen for colour, texture and size, because all these factors contribute to the final effect. Fine threads are usually employed on fine fabrics. Stranded threads, corded threads, highly-twisted lustrous threads, thick, matty, cotton thread and pure silk threads are mainly used in hand embroidery. They may also be used in Embroidery on adda depending upon the design and materials.

Before beginning embroidery work, ensure colour Fastness of both the fabric as well as the thread used.

4. Write a process of setting adda and khaka work.

Setting of adda

The fabric which is to be embroidered is held onto the adda following an elaborate process, which requires great precision. The tightening of fabric is known as tangarna and involves more than one person. Adda is a wooden frame mainly used for aari work on which the

Fabric to be embroidered is stretched tightly, making it comfortable and suitable for working. This frame has adjustable wooden bars which are rested on four stools or stands at four corners. These frames can also be customised according to the width of the fabric. These

Frames are large and mainly made up of sheesham wood. It is strong, hard and durable, but sometimes bamboo is also used as an alternative material. One frame can provide accommodation to 4–6 artisans sitting on both of its sides. To sit in a comfortable manner, the height of the frame is usually 1.5–2 feet above the ground. The artisans, both male and female, sit either on the floor or on cushions. For smaller designs, small metal frames can be used instead of wooden planks. The adda or frame has four stands, two main bars and two sidebars. It is similar to the frames of a slate. The two main bars have evenly placed holes, through which a thick cotton rope is passed twice. A strip of cotton cloth is attached to one side (inner side) of the main bar. The embroiderer has to sit on the floor to embroider.

Attaching the fabric

1. The fabric is first joined to the two main bars.
2. The centres of the bar as well as of the fabric are marked on both sides and pinned up.
3. Cotton thread is used to sew the first side of the fabric to one of the cotton strips of the main bars.

4. To begin, a knot is made and to end, 4–5 back stitches are done onto the white cotton cloth, which is attached on the bars.
5. Then, the second side to the other bar is stitched and rolled.
6. Now, the stretcher bars are inserted and the frame is stretched to place the pegs or nails.
7. Then, the selvages are folded. Small darning stitches are sewn and the same thread passes through these stitches, then the fabric is pulled tightly. Now, the thread is pulled and tied to the peg or nail.
8. Now all the four sides of the fabric are stretched.

Khaka making process

In this process, a paper of design is pricked with a pin at regular intervals. The pattern is then pinned up to the fabric and a coloured chalk powder is spread through the holes in a pouncing motion using a soft fabric pad. Pouncing materials can be found in specialty needle workshops. The pattern pricked on the transparent sheet of paper, that is pinned to the fabric is called khaka.

MCQ ANSWER

1. Aari
2. Embroidery
3. Thimble
4. Adda
5. Aari

QUILTING

14.0 OBJECTIVES**14.1 INTRODUCTION****14.2 TOOLS AND MATERIALS****14.3 TRANSFERRING DESIGN ON FABRIC****14.4 CHECK YOUR PROGRESS I****14.5. METHOD****14.6 CHECK YOUR PROGRESS II****14.7 MULTIPLE CHOICE QUESTIONS****14.8 LET US SUM UP****14.9 KEYWORDS****14.10. SUGGESTED BOOKS****14.11. ANSWER**

14.0 OBJECTIVES

- To gain knowledge about quilting
- To learn quilting method
- To learn different type of quilting

14.1 INTRODUCTION

Quilting, like so many other needlecraft techniques, is centuries old. It has been valued as a source of warmth in the form of bed quilts and clothing. The basic quilting technique involves simple running stitches used to sew together two or more layers of fabric with padding. These stitches are worked in a systematic pattern to create a textured surface fabric. Even though, it is primarily used as a material to provide warmth, today it is viewed as an ornamentation and use on variety of articles to enhance a complete design surface such as patchwork or applique.

14.2 TOOLS AND MATERIALS

14.2.1 Materials required

- Layers of cloth, face fabric
- Sewing tools like needles (called as between needle used for quilting), a pair of Scissors, frames, matching thread etc.
- Material for stuffing such as cotton, wool, synthetic, an old Blanket etc.

14.2.2 Suitable fabrics

- Closely woven material that is soft and pliable and light to medium weight gives a smooth finish for all types of quilting.
- Cottons such as poplin, sheeting materials, muslin, broad cloth, pure Silk, fine wool etc. is highly suitable.
- Rich fabrics such as velvet, satin and silk can also be used for special quilted effects.
- Soft organdie, voile and organza are used for delicate effect.
- Heavy and stiff fabrics do not easily conform to the quilted contours and hence it is better to avoid.
- For backing or bottom layer, fine quality muslin is good. It has become decorative now-a-days and made from fabrics bright in pattern and colour and similar in style and type to the top fabric layer.
- Padding material may be cotton batting or polyester batting available in sheet form in the market. For filling, cotton wool serves the best. However, polyester will also produce the same effect.
- A thin light filling is very good in quilts. The advantage is that it is easier to sew compared to heavier or thicker filling. It is important to make small and even stitches in quilts. If the filling is thinner, it is much easier for the needle and the thread to go through. If quilt prepared is used in bed, then it is advisable to choose a thicker filling for warmth.

14.3 TRANSFERRING DESIGN ON FABRIC

14.3.1 Types of quilting designs

1. Outline quilting



(fig.1.outline quilting)

The outlines of the shapes are already present on the top fabric layer. Patchwork and appliqué are most commonly used for making this type of quilts. Sometimes selected areas of the shapes are given outline. Otherwise the outline of a shape is repeated in concentric quilting lines

2. All over patterns

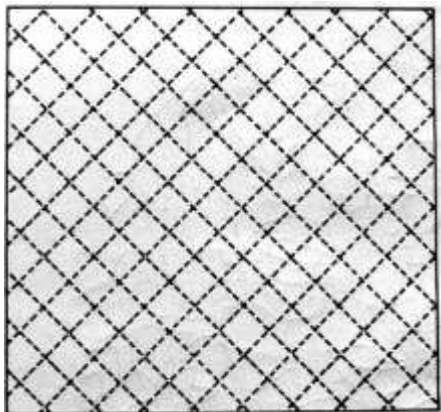

(fig.2.all over pattern)

It produces a regular pattern by repetition of one or more shapes. They are used to cover the entire surface with a simple background or fill open areas or within quilted motifs. It can be stitched in the form of straight line, criss cross, diamond shape, circle, half circle, combination of the lines or circles etc. according to the chosen design.

3. Ornamental patterns

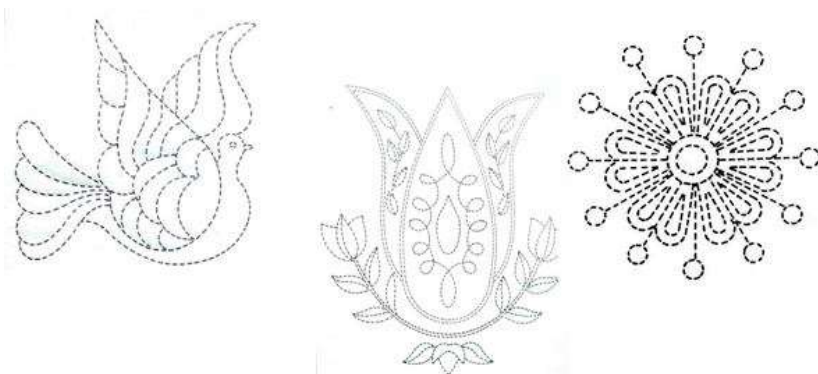

(fig.3.ornamental pattern)

Different kinds of motifs are used, either they can be purchased or prepared. These motifs usually contain intricate details and could be well seen when done on a plain fabric surfaces. Elaborate designs act as a central motif and smaller motifs may surround the centre design or corners.

4. Border patterns

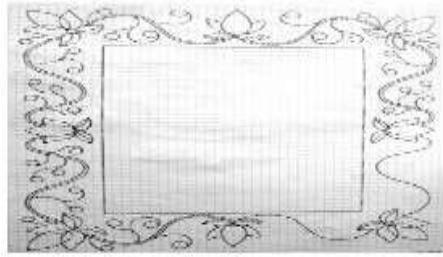

(fig.4.border pattern)

Border designs are made up of repeated patterns of motifs that frame and complement the main design on a quilt. Motifs like flowers, feathers, geometric shapes etc. can be used. Combination with related corner motifs also creates a different look. Plan any border design on a graph paper. Select the design and corner motifs then work out from each corner to centre of sides adjusting design repeats in between.

14.4 CHECK YOUR PROGRESS I

1. What is quilting?

2. Write a short list of tools and material for Quilting.

14.5. METHOD

Method of Quilting

Quilting is a method of joining two layers of fabric together to make a thicker padded material. It is done with 3 layers, the top fabric, filling material and backing material. The process of quilting uses a needle and thread to join all the three layers of the fabric to form a quilt.

1. Making templates:-

The designs can be transferred onto the fabric with dark pencil or templates of particular shapes, stencils of design etc. Templates are made from either cardboard or plastic in the same way as patchwork. First mark the outline of the templates and then fill in any internal details by hand or any stencil

templates cutting the major internal lines with long dashes, wide enough to draw with a pencil.

2. Marking quilting design:-

Quilt design is marked on the top fabric layer before it is assembled with the other layers and set into the frame or hoop. Marking off frame permits the entire design to be done at one time. The design is either drawn directly on the fabric or using templates of the chosen design with tailor's chalk or sharp pencil. First mark the outer edge of the quilting design with either a single or double line for finishing the raw edges. Next, draw motifs and border patterns.

Start at the centre of each border and work out to the corners to ensure that the pattern is symmetrical on all the sides.

3. Quilting process:-

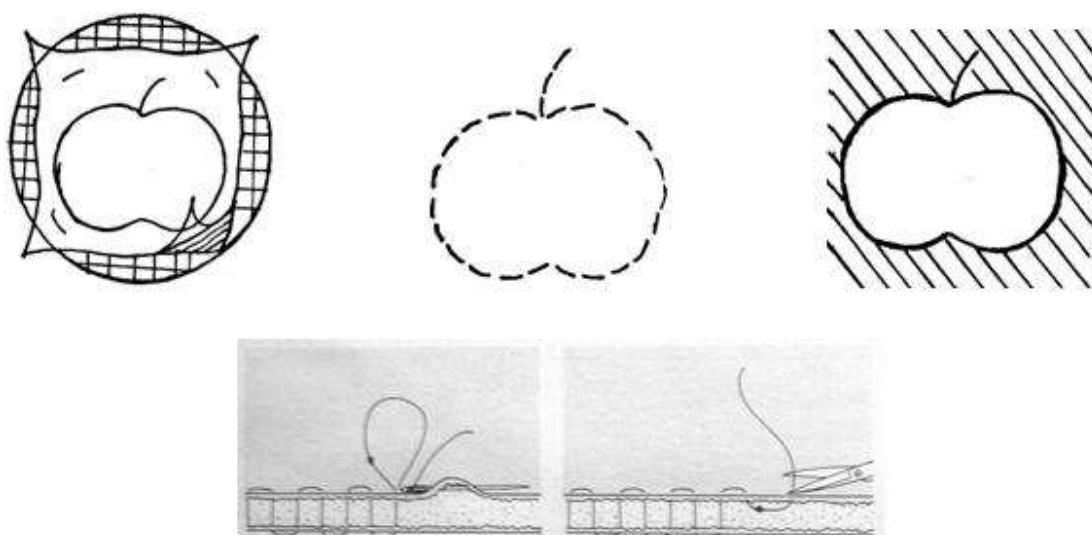

(fig.5. quilting process)

To work this equal dimension of upper fabric, lining fabric and backing fabric are fixed to the frame. These layers are tacked first to keep all layers together securely to remain smooth and wrinkle free throughout the quilting process. The design is worked either in running stitch if worked from down muslin side or backstitch from the upper layer. Maintain even stitches throughout and the number of stitches to take will vary according to the type and thickness of the wadding/batting. To avoid puckering on the fabric, work on the design from the center to the sides. To finish at the end of a pattern line, make a small knot close to the last stitch. Make a small stitch and pull the thread through to the back, anchoring the knot in the filling. Finish the raw edges either by folding edges together and stitch (self-binding) or separate binding.

4. Finishing edges:-

Finishing of the quilts is necessary to conceal the raw edges. It depends upon the type of quilt and its design. The edge finish should be planned from the beginning so that enough fabric is purchased.

5 .Self finished:-

There are two kinds of self-finish which are discussed below.

(1) Extended binding:-

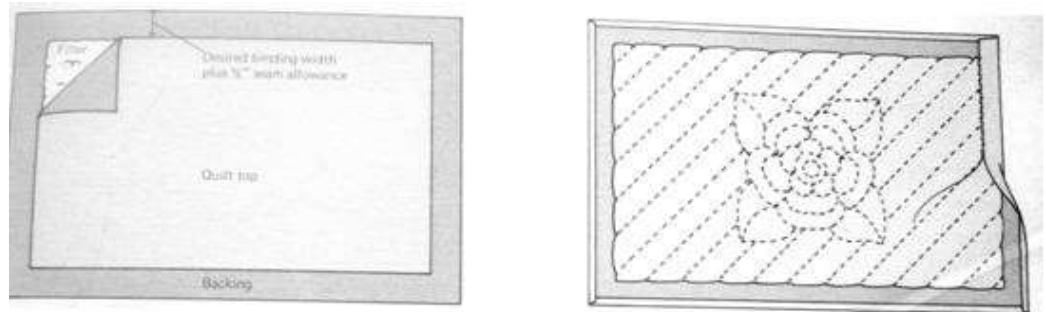

(fig.6. quilting process)

To prepare for self-finishing, the backing should be large enough to extend beyond the top piece by the desired binding width including seam allowance on all four sides. Cut both top and filler to finish the quilt size.

(1.1) Slip stitched edges:-

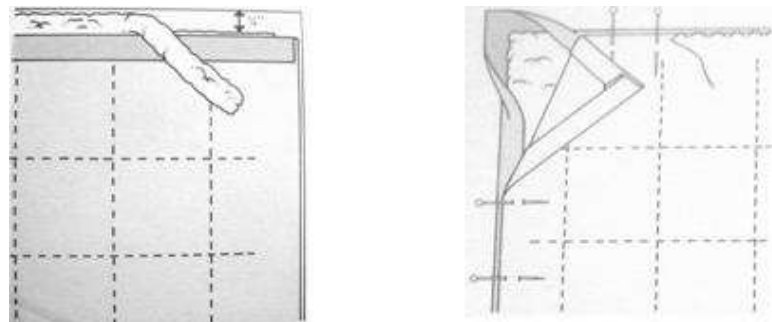

(fig.7. quilting process)

Line up the edges of the quilt top and backing. Trim the batting as it should be shorter than the top and backing fabrics. Fold the seam allowances from the top over the batting. Turn under the backing seam allowance. Align fold; pin and slip stitch them together.

Finishing the quilt using Slip stitched binding.

(1.2) Bound edges:-

Binding is a type of edge finish in which a separate strip of fabric is used to cover the raw edges of the quilt. It also helps to avoid bulky hem of the quilted garment. To make bias binding cut strips of fabric along the true bias of the fabric. For continuous binding the strips are cut to length that is enough for all the four sides.

(2) Single binding:-

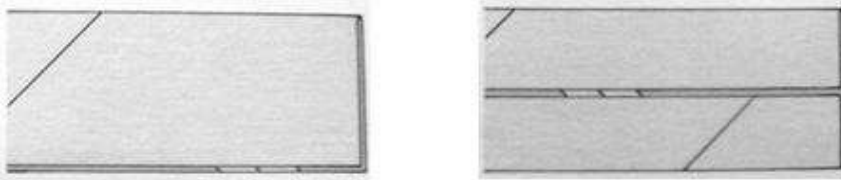

(fig.8. quilting process)

Fold the strip in half lengthwise with wrong sides facing and press the fold lightly. Open the pressed strip and fold the edge in so that they meet at the centre and then press. To apply on the fabric, open one folded edge with right side of binding facing quilt top, pin binding to the edge of the quilt. Stitch along the fold line of the binding. Press binding up and turn it over the raw edges so that the fold meets the stitched line on the backing. Pin it in place and slip stitch to seam line by hand.

(3) Double binding:-

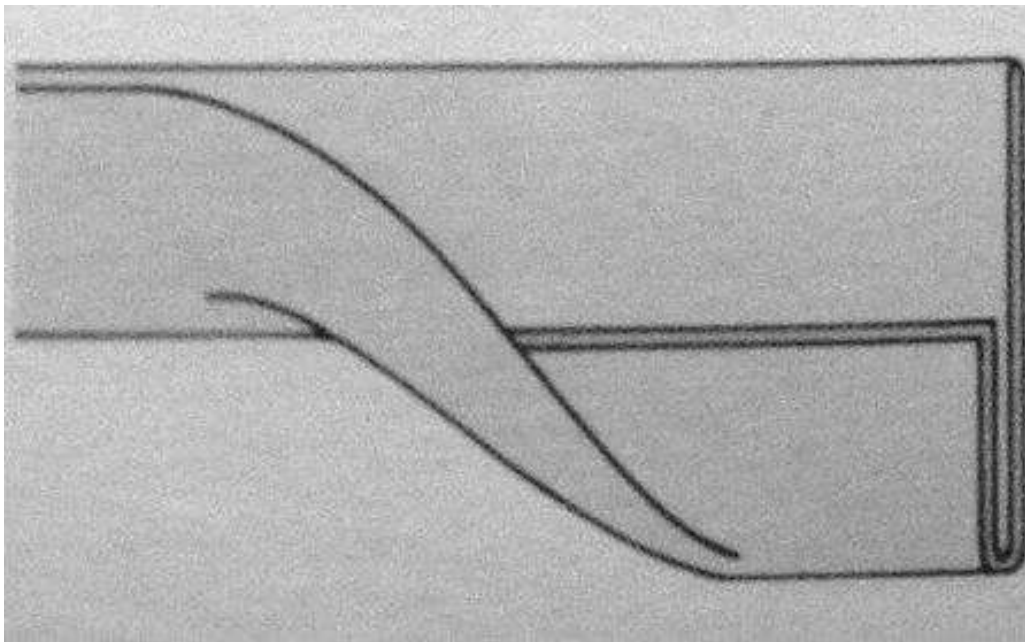

(fig.9. double binding)

For a double binding, fold the strip in half lengthwise then fold halved strip in place and press. To sew, open the folds and pin binding to the quilt top with raw edges of binding and quilt aligned. Stitch binding to quilt same as single binding.

(4) Handling corners:-

Corners in binding are applied in a curved or straight way. If a corner is curve, binding must be done on bias. If the corner is square, the binding can be applied so that corners are straight or metered. The techniques for all three remain same whether the binding is single or double.

Handling Curved Corners

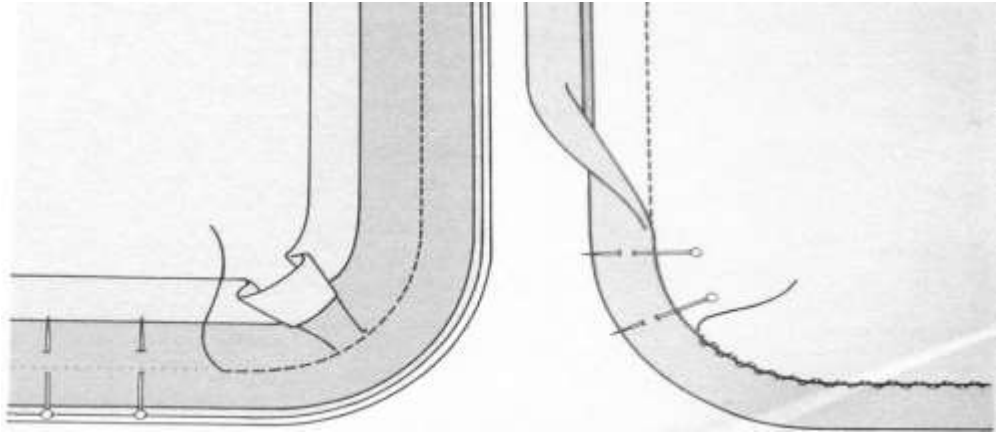

(fig.10.handling curved corners)

To bind a curved corner, pin bias binding to quilt edge as shown in gently stretch the binding to round the corner and stitch along the fold. Press binding up and fold over to the backing. Binding will naturally mould over the curved raw edge of the quilt and slip stitch to backing at stitch line.

(5) Binding a curved corner:-

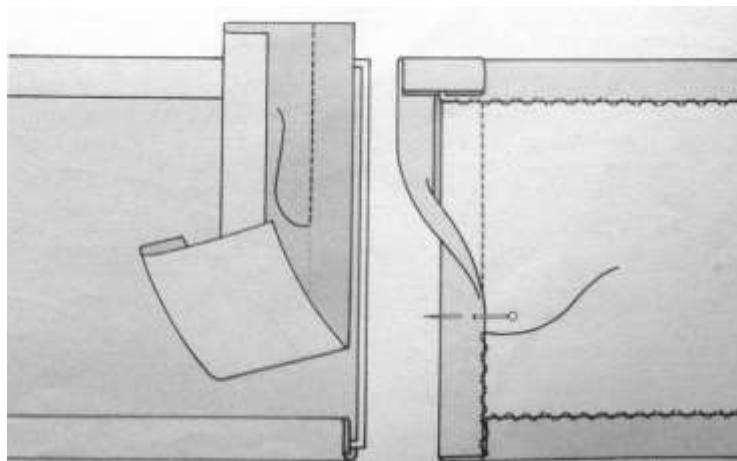

(fig.11.handling straight corners)

Handling Straight Corners

For straight corners, bind two opposite sides of the quilt. Then pin and stitch binding to one of the two remaining sides, letting the binding extend at both the ends. Turn the extended portion of the binding over the bound edge, and then finish binding the raw edge in the usual way. Repeat the same procedure to bind the remaining raw edge.

14.6 CHECK YOUR PROGRESS II

3. Write any two types of quilting.

4. Write a method of quilting.

14.7 MULTIPLE CHOICE QUESTIONS

1. _____ technique involves simple running stitches used to sew together two or more layers of fabric with padding.
- (E) Block printing (B) Tie-dye
(C) Crochet (D) Quilting
2. Which type of quilting produces a regular pattern by repetition of one or more shapes?
- (A) Outline (B) All over
(C) Ornamental (D) Boarder
3. _____ designs are made up of repeated patterns of motifs that frame and complement the main design on a quilt.
- (A) Ornamental (B) Boarder
(C) All over (D) Outline
4. The process of quilting uses a _____ and _____ to join all the three layers of the fabric to form a quilt.
- (A) Pen, pencil (B) Fabric, Needle
(C) Needle, Thread (D) Frame, Thread
5. Extended binding is use in _____
- (A) Making quilts (B) self-finished quilts
(C) Types of quilts (D) Transferring pattern for quilts

14.8 LET US SUM UP

The fabric craft like quilting have been in use from centuries by using the fabric. This is very simple to stitch and produce a variety of textile products. Quilting is primarily done to produce warmth by attaching two fabrics together with padding in between the fabrics. They are mostly used in bed spreads, art quilt wall hangings, clothing, and a variety of textile products. Basic stitches like running stitch, back stitch, slip stitch, buttonhole, zig zag etc. are used for finishing. It depends on the design and interest of the designer Different colours, patterns, textures and shapes of

fabric pieces are used to make quilts. Cotton/polyester wadding is used for placing in between the fabrics in quilting

14.9 KEYWORDS

1. WARMTH= a fairly high temperature or the effect created by this.
2. PLIABLE = easy to bend or shape.
3. WADDING = soft, thick material used to line garments or pack fragile items.
4. BATTING = layers or sheets of raw cotton material used for lining quilts.
5. ITRICATE= having many small parts or details put together in complicated way.
6. PERMITS = to allow something to happen.
7. WRINKLE = to form small lines and folds in something.
8. ELABORATE= very complicated, done or made very carefully.
9. PUCKERING = wrinkle, crinkle, crease

14.10. SUGGESTED BOOKS

1. The Quilter's Apprentice By Jenifer Chiavenin 1999.
 2. The Runway Quilts By Jenifer Chiavenin 2002
 3. Begginners Guide To Quilting By Elizabeth Betts
 4. All Things Quilting With Alex Anderson
- { Note: Figures Are Adapted From Suggested Book List And Source Of Non-Copyrighted Materials }

14.11. ANSWER

1. What is quilting?

The basic quilting technique involves simple running stitches used to sew together two or more layers of fabric with padding. These stitches are worked in a systematic pattern to create a textured surface fabric. Even though, it is primarily used as a material to provide warmth, today it is viewed as an ornamentation and use on variety of articles to enhance a completed design surface such as patchwork or applique

2. Write a short list of tools and material for Quilting.

- Layers of cloth, face fabric
- Sewing tools like needles (called as between needle used for quilting), Scissors, frames, matching thread etc.
- Material for stuffing such as cotton, wool, synthetic, an old Blanket etc. Suitable fabrics
- Closely woven material that is soft and pliable and light to medium Weight gives a smooth finish for all types of quilting.
- Cottons such as poplin, sheeting materials, muslin, broad cloth, pure Silk, fine wool etc. is highly suitable.
- Rich fabrics such as velvet, satin and silk can also be used for special quilted effects.
- Soft organzie, voile and organza are used for delicate effect.

- Heavy and stiff fabrics do not easily conform to the quilted contours and hence better to avoid.
- For backing or bottom layer, fine quality muslin is good. It has become decorative now-a-days and made from fabrics bright in pattern and colour and similar in style and type to the top fabric layer.
- Padding material may be cotton batting or polyester batting available in sheet form in the market. For filling, cotton wool serves best. However polyester will also produce the same effect.
- A thin light filling is very good in quilts. The advantage is that it is easier to sew compared to heavier or thicker filling. It is important to make small and even stitches in quilts. If the filling is thinner, it is much easier for the needle and the thread to go through. If quilt prepared is used in bed, then choose a thicker filling for warmth

3. Write any two types of quilting.

1 Outline quilting= the outlines of the shapes already present on the top fabric layer. Patchwork and appliqué are most commonly used for making this type of quilts. Sometimes selected areas of the shapes are given outline. Otherwise the outline of a shape is repeated in concentric quilting lines

2 All over pattern. =It produces a regular pattern by repetition of one or more shapes. They are used to cover the entire surface with a simple background or fill open areas or within quilted motifs. It can be stitched in the form of straight line, criss cross, diamond shape, circle, half circle, combination of the lines or circles etc. according to the chosen design.

4. Write a method of quilting.

Quilting is a method of joining two layers of fabric together to make a thicker padded material. It is done with 3 layers, the top fabric, filling material and backing material. The process of quilting uses a needle and thread to join all the three layers of the fabric to form a quilt.

1 Making templates:-

The designs can be transferred onto the fabric with dark pencil or templates of particular shapes, stencils of design etc. Templates are made from either cardboard or plastic in the same way as patchwork. First mark the outline of the templates and then fill in any internal details by hand or any stencil templates cutting the major internal lines with long dashes, wide enough to draw with a pencil.

2 Marking quilting design:-

Quilt design is marked on the top fabric layer before it is assembled with the other layers and set into the frame or hoop. Marking off frame permits the entire design to be done at one time. The design is either drawn directly on the fabric or using templates of the chosen design with tailor's chalk or sharp pencil. First mark the outer edge of the quilting design with either a single or double line for finishing the raw edges. Next, draw motifs and border patterns.

Start at the centre of each border and work out to the corners to ensure that the pattern is symmetrical on all the sides.

3 Quilting process:-

To work this equal dimension of upper fabric, lining fabric and backing fabric are fixed to the frame. These layers are tacked first to keep all layers together securely to remain smooth and wrinkle free throughout the quilting process. The design is worked either in running stitch if worked from down muslin side or backstitch from the upper layer. Maintain even stitches throughout and the number of stitches to take will vary according to the type and thickness of the wadding/batting. To avoid puckering on the fabric, work on the design from the center to the sides. To finish at the end of a pattern line, make a small knot close to the last stitch. Make a small stitch and pull the thread through to the back, anchoring the knot in the filling. Finish the raw edges either by folding edges together and stitch (self-binding) or separate binding.

4 Finishing edges:-

Finishing of the quilts is necessary to conceal the raw edges. It depends upon the type of quilt and its design. The edge finish should be planned from the beginning so that enough fabric is purchased.

MCQ ANSWER

- 1. Quilting**
- 2. All Over**
- 3. Boarder**
- 4. Needle, Thread**
- 5. Self-Finished Quilts**

યુનિવર્સિટી ગીત

સ્વાધ્યાય: પરમં તપ:

સ્વાધ્યાય: પરમં તપ:

સ્વાધ્યાય: પરમં તપ:

શિક્ષણ, સંસ્કૃતિ, સદ્ભાવ, દિવ્યબોધનું ધામ
ડૉ. બાબાસાહેબ આંબેડકર ઓપન યુનિવર્સિટી નામ;
સૌને સૌની પાંખ મળે, ને સૌને સૌનું આભ,
દશે દિશામાં સ્મિત વહે હો દશે દિશે શુભ-લાભ.

અભણ રહી અજ્ઞાનના શાને, અંધકારને પીવો ?
કહે બુદ્ધ આંબેડકર કહે, તું થા તારો દીવો;
શારદીય અજવાળા પહોંચ્યાં ગુર્જર ગામે ગામ
ધ્રુવ તારકની જેમ ઝળહળે એકલવ્યની શાન.

સરસ્વતીના મયૂર તમારે ફળિયે આવી ગહેકે
અંધકારને હડસેલીને ઉજાસના ફૂલ મહેંકે;
બંધન નહીં કો સ્થાન સમયના જવું ન ઘરથી દૂર
ઘર આવી મા હરે શારદા દૈન્ય તિમિરના પૂર.

સંસ્કારોની સુગંધ મહેંકે, મન મંદિરને ધામે
સુખની ટપાલ પહોંચે સૌને પોતાને સરનામે;
સમાજ કેરે દરિયે હાંકી શિક્ષણ કેરું વહાણ,
આવો કરીયે આપણ સૌ
ભવ્ય રાષ્ટ્ર નિર્માણ...
દિવ્ય રાષ્ટ્ર નિર્માણ...
ભવ્ય રાષ્ટ્ર નિર્માણ